

Appendix A: Public Consultation Documents

- 1. Newspaper adverts**
- 2. Consultation Register**
- 3. Questionnaire**
- 4. Communiques**

Adopt, Don't Shop!

HELLO!

They call me **RAFIKI**

10 TO 12 WEEKS OLD FEMALE DOG

For happy, wonderful, and fun times!



Rafiki, is a 10 months old female dog. My name means friend, in Kiswahili and best believe I live up to my name, once I've grown fond of my human and have built a bond, I enjoy average physical exercise, and I have a short easy-care coat. I know how to sit, and I walk really well on a leash. I am partially house trained. I would appreciate a home that allows me to sleep indoors for that is what I am accustomed to.

HELLO!

They call me **HUNTER**

3 YEAR OLD MALE CAT

For happy, wonderful, and fun times!



Hunter a 2-year-old male cat looking for his purrfect home. He is an easy-going cat, that enjoys the attention and affection he gets from humans. Hunter will thrive in a home with other cats.



SPCA Windhoek
145 Robert Mugabe Avenue,
Windhoek
Tel: 061-238 654
Emergency Cell: 081-124 4520
(After Hours Only)
Email: info@spcawindhoek.org.na



NOTIFICATION AND CALL FOR PUBLIC PARTICIPATION
ENVIRONMENTAL IMPACT ASSESSMENT (EIA) PROCESS FOR THE PROPOSED DEVELOPMENT OF 22 TELECOMMUNICATION BASE-TRANSCIVER STATION (BTS) TOWERS ON SELECTED SITES COUNTRYWIDE, NAMIBIA

D B P Engineers and Environmental Consultants hereby gives notice to all potentially interested and Affected Parties (I&AP) that an application will be made to the Environmental Commissioner in terms of the Environmental Management Act (No. 7 of 2007) and the Environmental Impact Assessment Regulations (GN 30 of 6 February 2012) for the proposed development of twenty two (22) base transceiver station (BTS) towers.

Powercom (PTY) LTD herein referred to as the proponent has identified different areas that needs improved communication alternatives in Namibia due to growth in population and economic activities. To achieve the objective of improved telecommunication connect with, Powercom has been appointed by Telecom Namibia its sister company to establish telecommunication towers across the identified different locations. In this respect, Powercom has identified sites to construct and operate 22 telecommunication base transceiver station towers across the country.

Powercom (the proponent) has appointed D B P Engineers and Environmental Consultants to conduct the EIA processes for these proposed BTS tower developments. The EIA is being conducted to satisfy the Namibian environmental legislative requirements. The general public as well as any interested and Affected Parties (I&AP) are hereby invited to register their concerns and notify the consultant of any potential environmental and social impacts that may be triggered by the project.

The proposed projects for which the Environmental Clearance Certificates will be applied for are as follows:

<p>1. Project Title: Environmental Impact Assessment (EIA) Study for the Proposed Construction and Operation of a Telecommunication Base Transceiver Station (BTS) Tower at Soehem Settlement, Erongo Region.</p> <p>Location: Soehem Settlement, Erongo Region - Namibia</p> <p>Coordinates: 26°49'02.3" S, 17°48'11.9" E</p>	<p>2. Project Title: Environmental Impact Assessment (EIA) Study for the Proposed Construction and Operation of a Telecommunication Base Transceiver Station (BTS) Tower at Lihongo Village in Oshana Region.</p> <p>Location: Lihongo Village, Oshana Region - Namibia</p> <p>Coordinates: 18°02'21.8" S 16°10'34.7" E</p>	<p>Project Title: Environmental Impact Assessment (EIA) Study for the Proposed Construction and Operation of a Telecommunication Base Transceiver Station (BTS) Tower at Otshandjo Village in Oshana Region - Namibia</p> <p>Location: Otshandjo Village in Oshana Region - Namibia</p> <p>Coordinates: 17°49'28.0" S 15°58'17.1" E</p>	<p>Project Title: Environmental Impact Assessment (EIA) Study for the Proposed Construction and Operation of a Telecommunication Base Transceiver Station (BTS) Tower at Onkoko Village in, Erongo Region - Namibia</p> <p>Location: Onkoko Village in, Erongo Region - Namibia</p> <p>Coordinates: 17°32'15.3" S 15°07'42.2" E</p>
<p>Project Title: Environmental Impact Assessment (EIA) Study for the Proposed Construction and Operation of a Telecommunication Base Transceiver Station (BTS) Tower at Oshahene Border Post, Erongo Region - Namibia</p> <p>Location: Oshahene Border Post, Erongo Region - Namibia</p> <p>Coordinates: 17°25'05.0" S 14°54'07.6" E</p>	<p>Project Title: Environmental Impact Assessment (EIA) Study for the Proposed Construction and Operation of a Telecommunication Base Transceiver Station (BTS) Tower at Erongo village, Erongo Region - Namibia</p> <p>Location: Springs village, Erongo Region - Namibia</p> <p>Coordinates: 17°28'37.9" S 16°26'34.7" E</p>	<p>Project Title: Environmental Impact Assessment (EIA) Study for the Proposed Construction and Operation of a Telecommunication Base Transceiver Station (BTS) Tower at Mugini Village in, Erongo West Region - Namibia</p> <p>Location: Mugini Village in, Erongo West Region - Namibia</p> <p>Coordinates: 17°52'48.8" S 15°57'52.4" E</p>	<p>Project Title: Environmental Impact Assessment (EIA) Study for the Proposed Construction and Operation of a Telecommunication Base Transceiver Station (BTS) Tower at Kangango Village in, Erongo East Region - Namibia</p> <p>Location: Kangango Village in, Erongo East Region - Namibia</p> <p>Coordinates: 17°57'01.7" S 15°59'52.5" E</p>
<p>Project Title: Environmental Impact Assessment (EIA) Study for the Proposed Construction and Operation of a Telecommunication Base Transceiver Station (BTS) Tower at Gurus, Oshana Region - Namibia</p> <p>Location: Gurus, Oshana Region - Namibia</p> <p>Coordinates: 18°14'52.4" S 17°20'55.3" E</p>	<p>Project Title: Environmental Impact Assessment (EIA) Study for the Proposed Construction and Operation of a Telecommunication Base Transceiver Station (BTS) Tower at Isuarua Village in, Erongo Region - Namibia</p> <p>Location: Isuarua Village, Erongo Region - Namibia</p> <p>Coordinates: 17°47'28.3" S 14°36'46.9" E</p>	<p>Project Title: Environmental Impact Assessment (EIA) Study for the Proposed Construction and Operation of a Telecommunication Base Transceiver Station (BTS) Tower at Dobsi Brookwater in, Erongo Region - Namibia</p> <p>Location: Dobsi Brookwater in, Erongo Region - Namibia</p> <p>Coordinates: 22°52'07.1" S 17°05'37.6" E</p>	<p>Project Title: Environmental Impact Assessment (EIA) Study for the Proposed Construction and Operation of a Telecommunication Base Transceiver Station (BTS) Tower at Nowobes 51 in, Erongo Region - Namibia</p> <p>Location: Nowobes Settlement, Erongo Region - Namibia</p> <p>Coordinates: 26°49'02.3" S, 17°48'11.9" E</p>
<p>Project Title: Environmental Impact Assessment (EIA) Study for the Proposed Construction and Operation of a Telecommunication Base Transceiver Station (BTS) Tower at Uuyoka village, Erongo Region - Namibia</p> <p>Location: Uuyoka village, Erongo Region - Namibia</p> <p>Coordinates: 17°57'34.7" S 16°16'39.1" E</p>	<p>Project Title: Environmental Impact Assessment (EIA) Study for the Proposed Construction and Operation of a Telecommunication Base Transceiver Station (BTS) Tower at Uuuviva Village in, Erongo Region - Namibia</p> <p>Location: Uuuviva Village in, Erongo Region - Namibia</p> <p>Coordinates: 18°05'05.7" S 15°27'55.3" E</p>	<p>Project Title: Environmental Impact Assessment (EIA) Study for the Proposed Construction and Operation of a Telecommunication Base Transceiver Station (BTS) Tower at Namakope Village in, Erongo Region - Namibia</p> <p>Location: Namakope Village in, Erongo Region - Namibia</p> <p>Coordinates: 17°28'41.0" S 15°00'51.0" E</p>	<p>Project Title: Environmental Impact Assessment (EIA) Study for the Proposed Construction and Operation of a Telecommunication Base Transceiver Station (BTS) Tower at Otshandjo Village in, Erongo Region - Namibia</p> <p>Location: Otshandjo Village in, Erongo Region - Namibia</p> <p>Coordinates: 17°34'05.9" S 15°16'35.6" E</p>
<p>Project Title: Environmental Impact Assessment (EIA) Study for the Proposed Construction and Operation of a Telecommunication Base Transceiver Station (BTS) Tower at Tondoro Settlement in, Erongo West Region - Namibia</p> <p>Location: Tondoro Settlement in, Erongo West Region - Namibia</p> <p>Coordinates: 17°46'17.6" S 16°47'28.3" E</p>	<p>Project Title: Environmental Impact Assessment (EIA) Study for the Proposed Construction and Operation of a Telecommunication Base Transceiver Station (BTS) Tower at Hinganga Limes Settlement in Erongo East Region - Namibia</p> <p>Location: Hinganga Limes Settlement in Erongo East Region - Namibia</p> <p>Coordinates: 17°57'08.8" S 16°28'12.6" E</p>	<p>Project Title: Environmental Impact Assessment (EIA) Study for the Proposed Construction and Operation of a Telecommunication Base Transceiver Station (BTS) Tower at Gungwa Settlement in, Erongo East Region - Namibia</p> <p>Location: Gungwa Settlement in, Erongo East Region - Namibia</p> <p>Coordinates: 18°01'14.8" S 17°28'15.4" E</p>	<p>Project Title: Environmental Impact Assessment (EIA) Study for the Proposed Construction and Operation of a Telecommunication Base Transceiver Station (BTS) Tower at Namakope Village in, Erongo Region - Namibia</p> <p>Location: Namakope Village in, Erongo Region - Namibia</p> <p>Coordinates: 17°46'23.7" S 16°56'11.0" E</p>
<p>Project Title: Environmental Impact Assessment (EIA) Study for the Proposed Construction and Operation of a Telecommunication Base Transceiver Station (BTS) Tower at Mulkibia Village in Erongo Region - Namibia</p> <p>Location: Mulkibia Village in Erongo Region - Namibia</p> <p>Coordinates: 17°55'40.4" S 14°57'42.0" E</p>	<p>Project Title: Environmental Impact Assessment (EIA) Study for the Proposed Construction and Operation of a Telecommunication Base Transceiver Station (BTS) Tower at Waias Bay Extension 17 in, Erongo Region - Namibia</p> <p>Location: Waias Bay Extension 17 in, Erongo Region - Namibia</p> <p>Coordinates: To be confirmed</p>		

Contact Details: D B P Engineers and Environmental Consultants
Attention: Mr. T. Kaaligael
PO Box 8401, Windhoek, Namibia
Email: tdk@dbp.com.na
Tel: +264 61 302672

Interested & Affected Parties (I&AP) Registration and submission of comments: To comment or receive further information on the project, please register with the consultant (contact details below) as an I&AP before end of business on 25 September 2022. A Background Information Document (BID) has been compiled for the project and is available upon request to the consultant, contact below.

All registered I&APs will be informed throughout the assessment process and will be provided with further opportunities for review and submission of comments. Comments can also be lodged via the online form given:
<https://forms.gle/7NkCubnQm8u8dR>



HOME LOAN INVESTMENT CC
Reg. cc: 2009/0449

P.O. BOX 2028, Grootfontein
Tel: 067-240 210
Cell: +264 81 249 1923
Email: home loans@hli.com.na

NB: We are inviting our new clients to register and qualify to be given loans within a period of 48 working hours, we offer the minimum loan amount of N\$5,000.00 to maximum amount N\$250,000.00 to private individuals, both employed and unemployed persons are welcome to register for a loan, in order to register clients should have the following documents:

- Membership registration fee of N\$150.00 (COMPULSARY) advantage:
 - Identity document, source code, passport, driver's license.
 - Latest pay slip, 3 months bank statement.
- NOTE: Approval in 48 working hours period to arrange to pay back the loan between 18 - 48 months.
- Please take note: Backlog clients or C/C record are acceptable on reasonable verifiable condition.

Home Loan Investment CC is pleased to inform our valuable clients that telephonically consultation, application to clients are acceptable and convenient will be provided by Home Loan Investment CC and available before approval to complete and professional service.

CONTACT THE DIRECTOR
Mr Nicco at Grootfontein main branch at Orpenville Mall Complex
Office Hours: MON-FRI 08H00 to 16H30
TELE: 067 240 210 / CELL: 0812 496 823
FAX: 067 243 436 | Email: home loans@hli.com.na

WANT TO ADVERTISE?

Email: sales@observer.com.na
marketing@observer.com.na

CLASSIFIEDS



Rafiki, is a 10 months old female dog. My name means friend, in Kiswahili and best believe I live up to my name, once I've grown fond of my human and have built a bond, I enjoy average physical exercise, and I have a short easy-care coat. I know how to sit, and I walk really well on a leash. I am partially house trained. I would appreciate a home that allows me to sleep indoors for that is what I am accustomed to.



Hunter a 2-year-old male cat looking for his purrfect home. He is an easy going cat, that enjoys the attention and affection he gets from humans. Hunter will thrive in a home with other cats.



SPCA Windhoek
145 Robert Mugabe Avenue,
Windhoek
Tel: 061-238 654
Emergency Cell: 081-124 4520
(After Hours Only)
Email: info@spcawindhoek.org.na



NOTIFICATION AND CALL FOR PUBLIC PARTICIPATION ENVIRONMENTAL IMPACT ASSESSMENT (EIA) PROCESS FOR THE PROPOSED DEVELOPMENT OF 22 TELECOMMUNICATION BASE-TRANSCIVER STATION (BTS) TOWERS ON SELECTED SITES COUNTRYWIDE, NAMIBIA



D & P Engineers and Environmental Consultants hereby gives notice to all potentially Interested and Affected Parties (I&APs) that an application will be made to the Environmental Commissioner in terms of the Environmental Management Act (No. 7 of 2007) and the Environmental Impact Assessment Regulations (No. 30 of 1 February 2012), for the proposed development of twenty two (22) base transceiver station (BTS) towers.

Powercom (PTY) LTD herein referred to as the proponent has identified different areas that needs improved communication alternatives in Namibia due to growth in population and economic activities. To achieve the objective of improved telecommunication connectivity, Powercom has been appointed by Telecom Namibia its sister company to establish telecommunication towers across the identified different locations. In this respect, Powercom has identified sites to construct and operate 22 telecommunication base transceiver station towers across the country.

Powercom (the proponent) has appointed D&P Engineers and Environmental Consultants to conduct the EIA process for these proposed BTS tower developments. The EIA is being conducted to satisfy the Namibian environmental legislative requirements. The general public as well as any Interested and Affected Parties (I&APs) are hereby invited to register their concerns and notify the consultant of any potential environmental and social impacts that may be triggered by the project.

The proposed projects for which the Environmental Clearance Certificates will be applied for are as follows:

<p>1. Project Title: Environmental Impact Assessment (EIA) Study for the Proposed Construction and Operation of a Telecommunication Base Transceiver Station (BTS) Tower at Sebem Settlement in, Karas Region.</p> <p>Location: Sebem Settlement, Karas Region - Namibia</p> <p>Coordinates: 26°49'02.8"S, 17°48'11.5"E</p>	<p>2. Project Title: Environmental Impact Assessment (EIA) Study for the Proposed Construction and Operation of a Telecommunication Base Transceiver Station (BTS) Tower at Lihongo Village in, Oshana Region.</p> <p>Location: Lihongo Village, Oshana Region - Namibia</p> <p>Coordinates: 18°02'21.8"S, 18°30'24.7"E</p>	<p>Project Title: Environmental Impact Assessment (EIA) Study for the Proposed Construction and Operation of a Telecommunication Base Transceiver Station (BTS) Tower at Oshandja Village in Oshana Region.</p> <p>Location: Oshandja Village in Oshana Region - Namibia</p> <p>Coordinates: 17°49'28.0"S, 15°38'17.1"E</p>	<p>Project Title: Environmental Impact Assessment (EIA) Study for the Proposed Construction and Operation of a Telecommunication Base Transceiver Station (BTS) Tower at Oshana Village in, Oshana Region.</p> <p>Location: Oshana Village in, Oshana Region - Namibia</p> <p>Coordinates: 17°52'15.3"S, 15°37'42.2"E</p>
<p>Project Title: Environmental Impact Assessment (EIA) Study for the Proposed Construction and Operation of a Telecommunication Base Transceiver Station (BTS) Tower at Oshaneene Border Post, Oshana Region.</p> <p>Location: Oshaneene Border Post, Oshana Region - Namibia</p> <p>Coordinates: 17°25'05.0"S, 14°34'07.8"E</p>	<p>Project Title: Environmental Impact Assessment (EIA) Study for the Proposed Construction and Operation of a Telecommunication Base Transceiver Station (BTS) Tower at Epanga Village, Oshana Region.</p> <p>Location: Epanga Village, Oshana Region - Namibia</p> <p>Coordinates: 17°24'42.3"S, 18°20'14.7"E</p>	<p>Project Title: Environmental Impact Assessment (EIA) Study for the Proposed Construction and Operation of a Telecommunication Base Transceiver Station (BTS) Tower at Mujiji Village in, Karungo West Region - Namibia</p> <p>Location: Mujiji Village in, Karungo West Region - Namibia</p> <p>Coordinates: 17°52'48.8"S, 18°37'52.4"E</p>	<p>Project Title: Environmental Impact Assessment (EIA) Study for the Proposed Construction and Operation of a Telecommunication Base Transceiver Station (BTS) Tower at Kangongo Village in, Karungo East Region.</p> <p>Location: Kangongo Village in, Karungo East Region - Namibia</p> <p>Coordinates: 17°57'01.7"S, 22°09'52.5"E</p>
<p>Project Title: Environmental Impact Assessment (EIA) Study for the Proposed Construction and Operation of a Telecommunication Base Transceiver Station (BTS) Tower at Gurus, Oshana Region - Namibia</p> <p>Location: Gurus, Oshana Region - Namibia</p> <p>Coordinates: 18°14'52.4"S, 17°20'55.3"E</p>	<p>Project Title: Environmental Impact Assessment (EIA) Study for the Proposed Construction and Operation of a Telecommunication Base Transceiver Station (BTS) Tower at Kunene Village in, Zambezi Region.</p> <p>Location: Kunene Village, Zambezi Region - Namibia</p> <p>Coordinates: 17°47'28.3"S, 24°36'56.5"E</p>	<p>Project Title: Environmental Impact Assessment (EIA) Study for the Proposed Construction and Operation of a Telecommunication Base Transceiver Station (BTS) Tower at Dolra Braaiwer in, Karas Region.</p> <p>Location: Dolra Braaiwer in, Karas Region - Namibia</p> <p>Coordinates: 22°25'02.3"S, 17°05'37.6"E</p>	<p>Project Title: Environmental Impact Assessment (EIA) Study for the Proposed Construction and Operation of a Telecommunication Base Transceiver Station (BTS) Tower at Howebes 31 in, Karas Region.</p> <p>Location: Howebes Settlement, Karas Region - Namibia</p> <p>Coordinates: 18°49'02.3"S, 17°48'11.5"E</p>
<p>Project Title: Environmental Impact Assessment (EIA) Study for the Proposed Construction and Operation of a Telecommunication Base Transceiver Station (BTS) Tower at Uuyuka Village, Oshana Region.</p> <p>Location: Uuyuka Village, Oshana Region - Namibia</p> <p>Coordinates: 17°57'24.7"S, 18°20'33.1"E</p>	<p>Project Title: Environmental Impact Assessment (EIA) Study for the Proposed Construction and Operation of a Telecommunication Base Transceiver Station (BTS) Tower at Uuovulpa Village in, Oshana Region.</p> <p>Location: Uuovulpa Village in, Oshana Region - Namibia</p> <p>Coordinates: 18°58'05.7"S, 15°27'55.3"E</p>	<p>Project Title: Environmental Impact Assessment (EIA) Study for the Proposed Construction and Operation of a Telecommunication Base Transceiver Station (BTS) Tower at Namakwale Amunungwile Village in, Oshana Region.</p> <p>Location: Namakwale Amunungwile Village in, Oshana Region - Namibia</p> <p>Coordinates: 17°29'42.0"S, 15°08'51.0"E</p>	<p>Project Title: Environmental Impact Assessment (EIA) Study for the Proposed Construction and Operation of a Telecommunication Base Transceiver Station (BTS) Tower at Oshandja Village in, Oshana Region.</p> <p>Location: Oshandja Village in, Oshana Region - Namibia</p> <p>Coordinates: 17°54'05.8"S, 15°38'25.8"E</p>
<p>Project Title: Environmental Impact Assessment (EIA) Study for the Proposed Construction and Operation of a Telecommunication Base Transceiver Station (BTS) Tower at Tandora Settlement in, Karungo West Region - Namibia</p> <p>Location: Tandora Settlement in, Karungo West Region - Namibia</p> <p>Coordinates: 17°46'17.6"S, 18°17'23.5"E</p>	<p>Project Title: Environmental Impact Assessment (EIA) Study for the Proposed Construction and Operation of a Telecommunication Base Transceiver Station (BTS) Tower at Ndonga Lintea Settlement in Karungo East Region - Namibia</p> <p>Location: Ndonga Lintea Settlement in Karungo East Region - Namibia</p> <p>Coordinates: 17°57'06.8"S, 20°28'12.0"E</p>	<p>Project Title: Environmental Impact Assessment (EIA) Study for the Proposed Construction and Operation of a Telecommunication Base Transceiver Station (BTS) Tower at Dvosh Settlement in, Karungo East Region - Namibia</p> <p>Location: Dvosh Settlement in, Karungo East Region - Namibia</p> <p>Coordinates: 18°09'14.8"S, 21°28'15.9"E</p>	<p>Project Title: Environmental Impact Assessment (EIA) Study for the Proposed Construction and Operation of a Telecommunication Base Transceiver Station (BTS) Tower at Nalibobekus Village in, Zambezi Region.</p> <p>Location: Nalibobekus Village in, Zambezi Region - Namibia</p> <p>Coordinates: 17°49'23.7"S, 24°50'11.0"E</p>
<p>Project Title: Environmental Impact Assessment (EIA) Study for the Proposed Construction and Operation of a Telecommunication Base Transceiver Station (BTS) Tower at Mutikilla Village in Zambezi Region.</p> <p>Location: Mutikilla Village in Zambezi Region - Namibia</p> <p>Coordinates: 17°55'40.4"S, 24°37'42.0"E</p>	<p>Project Title: Environmental Impact Assessment (EIA) Study for the Proposed Construction and Operation of a Telecommunication Base Transceiver Station (BTS) Tower at Walvis Bay Extension 17 in, Erongo Region - Namibia</p> <p>Location: Walvis Bay Extension 17 in, Erongo Region - Namibia</p> <p>Coordinates: To be Confirmed</p>		

Contact Details: D&P Engineers and Environmental Consultants
Attention: Mr. T Kedingeni
PO Box 8402, Windhoek, Namibia
Email: t.kedingeni@dap.com.na
Tel: +264 61 302672

Interested & Affected Parties (I&AP) Registration and submission of comments: To comment or receive further information on the project, please register with the consultant (contact details below) as an I&AP before end of business on **25 September 2022**. A Background Information Document (BID) has been compiled for the project and is available upon request to the consultant, contact below.

All registered I&APs will be informed throughout the assessment process and will be provided with further opportunities for review and submission of comments. Comments can also be lodged via the online form given.

<https://forms.gle/9F6C6mDpU6u60>

INFORMATION AND COMMUNICATION TECHNOLOGY FOCUS - 30 SEPTEMBER 2022

TECHNOLOGY ENHANCEMENTS
ARTIFICIAL INTELLIGENCE
BOARDROOM SOLUTIONS
PAYMENT SOLUTIONS
DATA MANAGEMENT
COMMUNICATION
GAMING
MORE...

BOOK YOUR
ADVERTISING
AND EDITORIAL
SPACE TODAY!



CONTACT PETER ON 085 750 6616 OR advertise@observer.com.na



**NOTIFICATION AND CALL FOR PUBLIC PARTICIPATION
ENVIRONMENTAL IMPACT ASSESSMENT (EIA) PROCESS FOR THE PROPOSED DEVELOPMENT OF 22
TELECOMMUNICATION BASE-TRANSCIVER STATION (BTS) TOWERS ON SELECTED SITES COUNTRYWIDE, NAMIBIA**

D & P Engineers and Environmental Consultants hereby gives notice to all potentially interested and Affected Parties (I&AP) that an application will be made to the Environmental Commissioner in terms of the Environmental Management Act (No 7 of 2007) and the Environmental Impact Assessment Regulations (GN 30 of 6 February 2012) for the proposed development of twenty two (22) base transceiver station (BTS) towers.

Powercom (PTY) LTD herein referred to as the proponent has identified different areas that needs improved communication alternatives in Namibia due to growth in population and economic activities. To achieve the objective of improved telecommunication connectivity, Powercom has been appointed by Telecom Namibia's sister company to establish telecommunication towers across the identified different locations. In this respect, Powercom has identified sites to construct and operate 22 telecommunication base transceiver station towers across the country.

Powercom (the proponent) has appointed D&P Engineers and Environmental Consultants to conduct the EIA process for these proposed BTS tower developments. The EIA is being conducted to satisfy the Namibian environmental legislative requirements. The general public as well as any interested and Affected Parties (I&AP) are hereby invited to register their concerns and notify the consultant of any potential environmental and social impacts that may be triggered by the project.

The proposed projects for which the Environmental Clearance Certificates will be applied for are as follows:

<p>1. Project Title: Environmental Impact Assessment (EIA) Study for the Proposed Construction and Operation of a Telecommunication Base Transceiver Station (BTS) Tower at Seehelm Settlement in Eraras Region.</p> <p>Location: Seehelm Settlement, Eraras Region - Namibia</p> <p>Coordinates: 26°49'02.8"S, 17°48'11.5"E</p>	<p>2. Project Title: Environmental Impact Assessment (EIA) Study for the Proposed Construction and Operation of a Telecommunication Base Transceiver Station (BTS) Tower at Ohango Village in Oshana Region.</p> <p>Location: Ohango Village, Oshana Region - Namibia</p> <p>Coordinates: 18°02'21.8"S 16°19'24.7"E</p>	<p>Project Title: Environmental Impact Assessment (EIA) Study for the Proposed Construction and Operation of a Telecommunication Base Transceiver Station (BTS) Tower at Otshandja Village in Oshana Region.</p> <p>Location: Otshandja Village in Oshana Region - Namibia</p> <p>Coordinates: 17°59'28.0"S 15°38'17.3"E</p>	<p>Project Title: Environmental Impact Assessment (EIA) Study for the Proposed Construction and Operation of a Telecommunication Base Transceiver Station (BTS) Tower at Otshoko Village in, Omusati Region.</p> <p>Location: Otshoko Village in, Omusati Region - Namibia</p> <p>Coordinates: 17°32'15.9"S 15°07'42.2"E</p>
<p>Project Title: Environmental Impact Assessment (EIA) Study for the Proposed Construction and Operation of a Telecommunication Base Transceiver Station (BTS) Tower at Ovaherero Border Post, Omusati Region.</p> <p>Location: Ovaherero Border Post, Omusati Region - Namibia</p> <p>Coordinates: 17°25'05.0"S 14°34'07.8"E</p>	<p>Project Title: Environmental Impact Assessment (EIA) Study for the Proposed Construction and Operation of a Telecommunication Base Transceiver Station (BTS) Tower at Epanga Village, Oshana Region.</p> <p>Location: Epanga Village, Oshana Region - Namibia</p> <p>Coordinates: 17°24'37.5"S 16°26'14.7"E</p>	<p>Project Title: Environmental Impact Assessment (EIA) Study for the Proposed Construction and Operation of a Telecommunication Base Transceiver Station (BTS) Tower at Mupini Village in, Kavango West Region.</p> <p>Location: Mupini Village in, Kavango West Region - Namibia</p> <p>Coordinates: 17°52'48.6"S 19°37'52.4"E</p>	<p>Project Title: Environmental Impact Assessment (EIA) Study for the Proposed Construction and Operation of a Telecommunication Base Transceiver Station (BTS) Tower at Kangongo Village in, Kavango East Region.</p> <p>Location: Kangongo Village in, Kavango East Region - Namibia</p> <p>Coordinates: 17°57'01.7"S 21°09'52.5"E</p>
<p>Project Title: Environmental Impact Assessment (EIA) Study for the Proposed Construction and Operation of a Telecommunication Base Transceiver Station (BTS) Tower at Gulnas, Oshana Region.</p> <p>Location: Gulnas, Oshana Region - Namibia</p> <p>Coordinates: 20°14'52.4"S 17°20'53.9"E</p>	<p>Project Title: Environmental Impact Assessment (EIA) Study for the Proposed Construction and Operation of a Telecommunication Base Transceiver Station (BTS) Tower at Hamuse Village in, Zambezi Region.</p> <p>Location: Hamuse Village, Zambezi Region - Namibia</p> <p>Coordinates: 17°47'28.8"S 24°36'56.9"E</p>	<p>Project Title: Environmental Impact Assessment (EIA) Study for the Proposed Construction and Operation of a Telecommunication Base Transceiver Station (BTS) Tower at Dobra Brakwater in, Eraras Region.</p> <p>Location: Dobra Brakwater in, Eraras Region - Namibia</p> <p>Coordinates: 22°57'07.1"S 17°05'37.6"E</p>	<p>Project Title: Environmental Impact Assessment (EIA) Study for the Proposed Construction and Operation of a Telecommunication Base Transceiver Station (BTS) Tower at Howobees 51 in, Eraras Region.</p> <p>Location: Howobees Settlement, Eraras Region - Namibia</p> <p>Coordinates: 26°48'02.9"S, 17°48'11.5"E</p>
<p>Project Title: Environmental Impact Assessment (EIA) Study for the Proposed Construction and Operation of a Telecommunication Base Transceiver Station (BTS) Tower at Uyoaka village, Oshana Region.</p> <p>Location: Uyoaka village, Oshana Region - Namibia</p> <p>Coordinates: 17°57'24.7"S 16°18'39.1"E</p>	<p>Project Title: Environmental Impact Assessment (EIA) Study for the Proposed Construction and Operation of a Telecommunication Base Transceiver Station (BTS) Tower at Uunavuya Village in, Oshana Region.</p> <p>Location: Uunavuya Village in, Oshana Region - Namibia</p> <p>Coordinates: 18°08'05.7"S 15°27'53.3"E</p>	<p>Project Title: Environmental Impact Assessment (EIA) Study for the Proposed Construction and Operation of a Telecommunication Base Transceiver Station (BTS) Tower at Nakajale Anamulenge Village in, Omusati Region.</p> <p>Location: Nakajale Anamulenge Village in, Omusati Region - Namibia</p> <p>Coordinates: 17°29'41.0"S 15°00'51.0"E</p>	<p>Project Title: Environmental Impact Assessment (EIA) Study for the Proposed Construction and Operation of a Telecommunication Base Transceiver Station (BTS) Tower at Okupundu Village in, Omusati Region.</p> <p>Location: Okupundu Village in, Omusati Region - Namibia</p> <p>Coordinates: 17°34'05.9"S 15°36'25.6"E</p>
<p>Project Title: Environmental Impact Assessment (EIA) Study for the Proposed Construction and Operation of a Telecommunication Base Transceiver Station (BTS) Tower at Tandoro Settlement in, Kavango West Region.</p> <p>Location: Tandoro Settlement in, Kavango West Region - Namibia</p> <p>Coordinates: 17°48'13.6"S 16°47'28.5"E</p>	<p>Project Title: Environmental Impact Assessment (EIA) Study for the Proposed Construction and Operation of a Telecommunication Base Transceiver Station (BTS) Tower at Ntonga Liensa Settlement in Kavango East Region.</p> <p>Location: Ntonga Liensa Settlement in Kavango East Region - Namibia</p> <p>Coordinates: 17°57'06.8"S 20°28'12.6"E</p>	<p>Project Title: Environmental Impact Assessment (EIA) Study for the Proposed Construction and Operation of a Telecommunication Base Transceiver Station (BTS) Tower at Oiyogha Settlement in, Kavango East Region.</p> <p>Location: Oiyogha Settlement in, Kavango East Region - Namibia</p> <p>Coordinates: 18°05'14.6"S 21°28'15.4"E</p>	<p>Project Title: Environmental Impact Assessment (EIA) Study for the Proposed Construction and Operation of a Telecommunication Base Transceiver Station (BTS) Tower at Nakohelewa Village in, Zambezi Region.</p> <p>Location: Nakohelewa Village in, Zambezi Region - Namibia</p> <p>Coordinates: 17°49'23.7"S 24°50'11.0"E</p>
<p>Project Title: Environmental Impact Assessment (EIA) Study for the Proposed Construction and Operation of a Telecommunication Base Transceiver Station (BTS) Tower at Muliwila Village in Zambezi Region.</p> <p>Location: Muliwila Village in Zambezi Region - Namibia</p> <p>Coordinates: 17°55'40.4"S 24°37'42.0"E</p>	<p>Project Title: Environmental Impact Assessment (EIA) Study for the Proposed Construction and Operation of a Telecommunication Base Transceiver Station (BTS) Tower at Walvis Bay Extension 17 in, Erongo Region.</p> <p>Location: Walvis Bay Extension 17 in, Erongo Region - Namibia</p> <p>Coordinates: To be Confirmed</p>		

Contact Details: D&P Engineers and Environmental Consultants
Attention: Mr. I Kasingani
PO Box 8401, Windhoek, Namibia
Email: ikasingani@dpeng.com.na
Tel: +264 61 902672

Interested & Affected Parties (I&AP) Registration and submission of comments: To comment or receive further information on the project, please register with the consultant (contact details below) as an I&AP before end of business on 25 September 2022. A Background Information Document (BID) has been compiled for the project and is available upon request to the consultant, contact below.

All registered I&APs will be informed throughout the assessment process and will be provided with further opportunities for review and submission of comments. Comments can also be lodged via the online form given:

<https://forms.gle/P9KCo0m9Pw6G6w>



SITE INCEPTION REGISTER:

**ENVIRONMENTAL AND SOCIAL MANAGEMENT PLAN: THE PROPOSED TELECOMMUNICATION
BASE TRANSCIVER STATION (BTS) TOWER AT DIYOGHA SETTLEMENT, KAVANGO EAST REGION
-NAMIBIA.**

VENUE: DIYOGHA SETTLEMENT

TIME: 09:30

DATE: 20/Sept/2022

NAME	Organisation/ Location	PHONE NUMBER	SIGNATURE
TUHEHE STANISLAUS	Diyogha	081 7366144	STANI
longend	D&P Engineers & S&C	0812772777	
Mafeteje	Diyoqha	0813783710	
Kashoshu Justinus	-	0813403042	
Shoshova Mariam	Diyogha	081 6637959	
DINYANDO DI	DIYOQHA		
THIVANGO MATHIAS	Diyogha	08125514730	

NAME	Organisation/ Location	PHONE NUMBER	SIGNATURE
Dimu Djuca	Diyogha	0814180154	Dimu Djuca
MENDERE Leonard	Diyogha	0814280139	Leonard
Kakuyi Joseph K	Diyogha	0814223788	Joseph K
Diyanda Benedictus	Diyogha	0818126338	Benedictus
Mughadhi Joseph M	Diyogha	0815590395	Joseph M
Shaka Alfred	Diyogha	0813285151	Alfred
Mukurwati Mathew	Diyogha	0816621227	Mathew
Po Pa. M. H	Diyogha	0813020930	Po Pa. M. H
DISTO V T	Diyogha	0814095445	V T
Thientka Helena	Diyogha	0814236243	Helena
Kheure Patricia	Diyogha	0812735055	Patricia
Thindhamba Kristina	Diyogha	0813159021	Kristina
Khelele Rumana	Diyogha	081401987	Rumana
matende Nenansia	Diyogha	081691987	Nenansia
Diyanda Augusta	Diyogha	0818751155	Augusta
Maghambari ketarina	Diyogha		Mt.

REGISTRATION AND COMMENTS FORM

ENVIRONMENTAL AND SOCIAL MANAGEMENT PLAN: THE PROPOSED
TELECOMMUNICATION BASE TRANSCIEVER STATION (BTS) TOWER AT DIYOGHA
SETTLEMENT IN, KAVANGO EAST REGION-NAMIBIA.

KINDLY COMPLETE THIS FORM IN DETAIL AND RETURN TO:

D&P Engineers and environmental consultants
Environmental Consultant: Tendai E. Kasinganeti
Phone: +264813634904
Fax: +264 61 255 207
Email: tkasinganeti@dpe.com.na

PERSONAL DETAILS

Name & Surname..... *Popo H. M.*
Postal Address.....
Town..... *Diyoqha*..... Email *081 3020930*

What is your main area of interest regarding the proposed developments?

yes
faster internet networks
easy communication

Do you have any points of concern or support regarding the proposed projects?
If "yes", please briefly list these in point format:

YES / NO

Do you wish this project to proceed?

YES / NO

Popo H. M.
STAMP/SIGNATURE

REGISTRATION AND COMMENTS FORM

ENVIRONMENTAL AND SOCIAL MANAGEMENT PLAN: THE PROPOSED
TELECOMMUNICATION BASE TRANSCIVER STATION (BTS) TOWER AT DIYOGHA
SETTLEMENT IN, KAVANGO EAST REGION-NAMIBIA.

KINDLY COMPLETE THIS FORM IN DETAIL AND RETURN TO:

D&P Engineers and environmental consultants
Environmental Consultant: Tendai E. Kasinganeti
Phone: +264813634904
Fax: +264 61 255 207
Email: tkasinganeti@dpe.com.na

PERSONAL DETAILS

Name & Surname Mughodhi Joseph M
Postal Address
Town Diyoqha Email 0815590395

What is your main area of interest regarding the proposed developments?

Good internet access

Do you have any points of concern or support regarding the proposed projects?
If "yes", please briefly list these in point format:

Yes I support because its YES / NO
very much important to environment.

Do you wish this project to proceed?

YES / NO

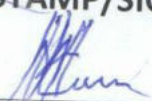
STAMP/SIGNATURE

REGISTRATION AND COMMENTS FORM

ENVIRONMENTAL AND SOCIAL MANAGEMENT PLAN: THE PROPOSED
TELECOMMUNICATION BASE TRANSCIEVER STATION (BTS) TOWER AT DIYOGHA
SETTLEMENT IN, KAVANGO EAST REGION-NAMIBIA.

KINDLY COMPLETE THIS FORM IN DETAIL AND RETURN TO:

D&P Engineers and environmental consultants
Environmental Consultant: Tendai E. Kasinganeti
Phone: +264813634904
Fax: +264 61 255 207
Email: tkasinganeti@dpe.com.na

PERSONAL DETAILS

Name & Surname Kashosho Faustinus
Postal Address Email 0813403042
Town Diyooha

What is your main area of interest regarding the proposed developments?

The development of in our village want
electricity. so
.....
.....

Do you have any points of concern or support regarding the proposed projects?
If "yes", please briefly list these in point format:

yes Because it not bring any
problem. safety. to us
want them to give us the electricity.
.....
.....

YES / NO

Do you wish this project to proceed?

YES / NO

[Signature]

STAMP/SIGNATURE

REGISTRATION AND COMMENTS FORM

ENVIRONMENTAL AND SOCIAL MANAGEMENT PLAN: THE PROPOSED
TELECOMMUNICATION BASE TRANSCIVER STATION (BTS) TOWER AT DIYOGHA
SETTLEMENT IN, KAVANGO EAST REGION-NAMIBIA.

KINDLY COMPLETE THIS FORM IN DETAIL AND RETURN TO:

D&P Engineers and environmental consultants
Environmental Consultant: Tendai E. Kasinganeti
Phone: +264813634904
Fax: +264 61 255 207
Email: tkasinganeti@dpe.com.na

PERSONAL DETAILS

Name & Surname Kasoko Dinyando
Postal Address Email
Town DIYOGHA

What is your main area of interest regarding the proposed developments?

we want electricity
.....
.....
.....

Do you have any points of concern or support regarding the proposed projects?
If "yes", please briefly list these in point format:

yes because it not bring any
effect to us
.....
.....
.....

YES / NO

Do you wish this project to proceed?

YES / NO

Kasoko
STAMP/SIGNATURE

REGISTRATION AND COMMENTS FORM

ENVIRONMENTAL AND SOCIAL MANAGEMENT PLAN: THE PROPOSED
TELECOMMUNICATION BASE TRANSCIEVER STATION (BTS) TOWER AT DIYOGHA
SETTLEMENT IN, KAVANGO EAST REGION-NAMIBIA.

KINDLY COMPLETE THIS FORM IN DETAIL AND RETURN TO:

D&P Engineers and environmental consultants
Environmental Consultant: Tendai E. Kasinganeti
Phone: +264813634904
Fax: +264 61 255 207
Email: tkasinganeti@dpe.com.na

PERSONAL DETAILS

Name & Surname PETRUS DINYANO
Postal Address P.O. Box 63489 WINDHOEK Email petrusdinyano@gmail.com
Town DIYOGHA

What is your main area of interest regarding the proposed developments?

My main interest regarding the proposed development is the
the network signal should be strength enough to
improve the telecommunication of the area.
Signal should be strength enough for internet connectivity
to be viable.

Do you have any points of concern or support regarding the proposed projects?
If "yes", please briefly list these in point format:

YES / NO

• Network signal should not fall like the
case at Andara which is always fail.

Do you wish this project to proceed?

YES / NO

STAMP/SIGNATURE



REGISTRATION AND COMMENTS FORM

ENVIRONMENTAL AND SOCIAL MANAGEMENT PLAN: THE PROPOSED
TELECOMMUNICATION BASE TRANSCIVER STATION (BTS) TOWER AT DIYOGHA
SETTLEMENT IN, KAVANGO EAST REGION-NAMIBIA.

KINDLY COMPLETE THIS FORM IN DETAIL AND RETURN TO:

D&P Engineers and environmental consultants
Environmental Consultant: Tendai E. Kasinganeti
Phone: +264813634904
Fax: +264 61 255 207
Email: tkasinganeti@dpe.com.na

PERSONAL DETAILS

Name & Surname *Kakuryi Joseph*
Postal Address *Diyooha* Email *phoniejoe@gmail.com*
Town *Diyooha* *10814223788*

What is your main area of interest regarding the proposed developments?

- *Fast working with internet*
- *Easy to communicate with out any network tower*

Do you have any points of concern or support regarding the proposed projects?
If "yes", please briefly list these in point format:

- YES / NO
- *My concern based on the proposed project is that tower should run or work on the solar panel power. Simply because we struggle on network when the electricity goes off.*

Do you wish this project to proceed?

YES / NO

STAMP/SIGNATURE

[Signature]
20/09/22

REGISTRATION AND COMMENTS FORM

ENVIRONMENTAL AND SOCIAL MANAGEMENT PLAN: THE PROPOSED
TELECOMMUNICATION BASE TRANSCIVER STATION (BTS) TOWER
~~XXXXXXXXXX~~
OSANIKOTO REGION, NAMIBIA.

KINDLY COMPLETE THIS FORM IN DETAIL AND RETURN TO:

D&P Engineers and environmental consultants
Environmental Consultant: Tendai E. Kasinganeti
Phone: +264813634904
Fax: +264 61 255 207
Email: tkasinganeti@dpe.com.na

PERSONAL DETAILS

Name & Surname *Mushiti Faustina Thijerera*
Postal Address *.....* Email *0817016741*
Town *Oyoqha*

What is your main area of interest regarding the proposed developments?

Business will be smart
Whatsapp will be easy
Easy communication
Fast internet

Do you have any points of concern or support regarding the proposed projects?
If "yes", please briefly list these in point format:

.....
.....
.....
.....
.....
.....
.....

YES / NO

Do you wish this project to proceed?

YES / NO

STAMP/SIGNATURE
Thijerera

REGISTRATION AND COMMENTS FORM

ENVIRONMENTAL AND SOCIAL MANAGEMENT PLAN: THE PROPOSED
TELECOMMUNICATION BASE TRANSCIEVER STATION (BTS) TOWER

~~SHIKOTO REGION NAMIBIA~~

~~GUINAS~~

KINDLY COMPLETE THIS FORM IN DETAIL AND RETURN TO:

D&P Engineers and environmental consultants
Environmental Consultant: Tendai E. Kasinganeti
Phone: +264813634904
Fax: +264 61 255 207
Email: tkasinganeti@dpe.com.na

PERSONAL DETAILS

Name & Surname Mayo Mambwe
Postal Address
Town Diyogha Email 0812387651

What is your main area of interest regarding the proposed developments?

faster internet
easy to communicate

Do you have any points of concern or support regarding the proposed projects?
If "yes", please briefly list these in point format:

yes it will bring development in the
community

YES / NO

Do you wish this project to proceed?

YES / NO

Mambo
STAMP/SIGNATURE

REGISTRATION AND COMMENTS FORM

ENVIRONMENTAL AND SOCIAL MANAGEMENT PLAN: THE PROPOSED
TELECOMMUNICATION BASE TRANSCIVER STATION (BTS) TOWER

KINDLY COMPLETE THIS FORM IN DETAIL AND RETURN TO:

D&P Engineers and environmental consultants
Environmental Consultant: Tendai E. Kasinganeti
Phone: +264813634904
Fax: +264 61 255 207
Email: tkasinganeti@dpe.com.na

PERSONAL DETAILS

Name & Surname Kutenda Bernhard
Postal Address Email 0818800209
Town Diyegha

What is your main area of interest regarding the proposed developments?

faster internet
.....
.....
.....

Do you have any points of concern or support regarding the proposed projects?
If "yes", please briefly list these in point format:

yes YES / NO
.....
.....
.....
.....

Do you wish this project to proceed?

YES / NO

STAMP/SIGNATURE

Kutenda Bernhard

REGISTRATION AND COMMENTS FORM

ENVIRONMENTAL AND SOCIAL MANAGEMENT PLAN: THE PROPOSED
TELECOMMUNICATION BASE TRANSCIVER STATION (BTS) TOWER AT DIYOGHA
SETTLEMENT IN, KAVANGO EAST REGION-NAMIBIA.

KINDLY COMPLETE THIS FORM IN DETAIL AND RETURN TO:

D&P Engineers and environmental consultants
Environmental Consultant: Tendai E. Kasinganeti
Phone: +264813634904
Fax: +264 61 255 207
Email: tkasinganeti@dpe.com.na

PERSONAL DETAILS

Name & Surname Porro Ambrasius
Postal Address Diyoqha Email 081.5624079
Town Diyoqha

What is your main area of interest regarding the proposed developments?

good evalit
I will receive good network

Do you have any points of concern or support regarding the proposed projects?
If "yes", please briefly list these in point format:

YES / NO

Do you wish this project to proceed?

YES / NO

STAMP/SIGNATURE



REGISTRATION AND COMMENTS FORM

ENVIRONMENTAL AND SOCIAL MANAGEMENT PLAN: THE PROPOSED
TELECOMMUNICATION BASE TRANSCIVER STATION (BTS) TOWER ~~AT MUTIKITHA~~
~~VILLAGE, NGOMA IN ZAMBEZI REGION, NAMIBIA.~~

KINDLY COMPLETE THIS FORM IN DETAIL AND RETURN TO:

D&P Engineers and environmental consultants
Environmental Consultant: Tendai E. Kasinganeti
Phone: +264813634904
Fax: +264 61 255 207
Email: tkasinganeti@dpe.com.na

PERSONAL DETAILS

Name & Surname Murerwa Mathew
Postal Address Email 0814083552
Town Etosha

What is your main area of interest regarding the proposed developments?

faster internet
easy communication
faster download

Do you have any points of concern or support regarding the proposed projects?
If "yes", please briefly list these in point format:

YES / NO

.....
.....
.....
.....
.....
.....
.....

Do you wish this project to proceed?

YES / NO

STAMP/SIGNATURE

REGISTRATION AND COMMENTS FORM

ENVIRONMENTAL AND SOCIAL MANAGEMENT PLAN: THE PROPOSED TELECOMMUNICATION BASE TRANSCIVER STATION (BTS) TOWER [REDACTED] [REDACTED] VILLAGE IN ZAMBEZI REGION, NAMIBIA.

KINDLY COMPLETE THIS FORM IN DETAIL AND RETURN TO:

D&P Engineers and environmental consultants
Environmental Consultant: Tendai E. Kasinganeti
Phone: +264813634904
Fax: +264 61 255 207
Email: tkasinganeti@dpe.com.na

PERSONAL DETAILS

Name & Surname Thidhimba Kristina Mbava
Postal Address N/A Email 0813159021
Town Diyagha

What is your main area of interest regarding the proposed developments?
The tower will bring electricity near by houses
Fast internet connection
Access to nearby school

Do you have any points of concern or support regarding the proposed projects? If "yes", please briefly list these in point format:

YES / NO

.....
.....
.....
.....
.....
.....
.....

Do you wish this project to proceed?

YES / NO

STAMP/SIGNATURE
Kina

REGISTRATION AND COMMENTS FORM

ENVIRONMENTAL AND SOCIAL MANAGEMENT PLAN: THE PROPOSED
TELECOMMUNICATION BASE TRANSCIVER STATION (BTS) TOWER AT DIYOGHA
SETTLEMENT IN, KAVANGO EAST REGION-NAMIBIA.

KINDLY COMPLETE THIS FORM IN DETAIL AND RETURN TO:

D&P Engineers and environmental consultants
Environmental Consultant: Tendai E. Kasinganeti
Phone: +264813634904
Fax: +264 61 255 207
Email: tkasinganeti@dpe.com.na

PERSONAL DETAILS

Name & Surname... *Shuto Alfred*
Postal Address.....
Town... *DiyoGha* Email... *081253285151*

What is your main area of interest regarding the proposed developments?

- *faster Internet network*
- *faster Whatsapp Network*
- *easy to call*

Do you have any points of concern or support regarding the proposed projects?
If "yes", please briefly list these in point format:

.....
.....
.....
.....
.....
.....
.....

YES / NO

Do you wish this project to proceed?

YES / NO

STAMP/SIGNATURE

Shuto

REGISTRATION AND COMMENTS FORM

ENVIRONMENTAL AND SOCIAL MANAGEMENT PLAN: THE PROPOSED
TELECOMMUNICATION BASE TRANSCEIVER STATION (BTS) TOWER AT DIYOGHA
SETTLEMENT IN, KAVANGO EAST REGION-NAMIBIA.

KINDLY COMPLETE THIS FORM IN DETAIL AND RETURN TO:

D&P Engineers and environmental consultants
Environmental Consultant: Tendai E. Kasinganeti
Phone: +264813634904
Fax: +264 61 255 207
Email: tkasinganeti@dpe.com.na

PERSONAL DETAILS

Name & Surname Mgendere Leonard K
Postal Address Email 0814280139
Town Diyoqha

What is your main area of interest regarding the proposed developments?

Internet
Wafy
Networks

Do you have any points of concern or support regarding the proposed projects?
If "yes", please briefly list these in point format:

No YES / NO
.....
.....
.....
.....
.....

Do you wish this project to proceed?

YES / NO

STAMP/SIGNATURE

K

REGISTRATION AND COMMENTS FORM

ENVIRONMENTAL AND SOCIAL MANAGEMENT PLAN: THE PROPOSED
TELECOMMUNICATION BASE TRANSCIVER STATION (BTS) TOWER AT DIYOGHA
SETTLEMENT IN, KAVANGO EAST REGION-NAMIBIA.

KINDLY COMPLETE THIS FORM IN DETAIL AND RETURN TO:

D&P Engineers and environmental consultants
Environmental Consultant: Tendai E. Kasinganeti
Phone: +264813634904
Fax: +264 61 255 207
Email: tkasinganeti@dpe.com.na

PERSONAL DETAILS

Name & Surname Thivonago Mathew
Postal Address Email 0814181247
Town Diyo gha

What is your main area of interest regarding the proposed developments?

It will be easy us to do business
Network will be free to every place
It will bring development to our village.

Do you have any points of concern or support regarding the proposed projects?
If "yes", please briefly list these in point format:

YES / NO

NO

Do you wish this project to proceed?

YES / NO

STAMP/SIGNATURE

REGISTRATION AND COMMENTS FORM

ENVIRONMENTAL AND SOCIAL MANAGEMENT PLAN: THE PROPOSED
TELECOMMUNICATION BASE TRANSCIEVER STATION (BTS) TOWER AT DIYOGHA
SETTLEMENT IN, KAVANGO EAST REGION-NAMIBIA.

KINDLY COMPLETE THIS FORM IN DETAIL AND RETURN TO:

D&P Engineers and environmental consultants
Environmental Consultant: Tendai E. Kasinganeti
Phone: +264813634904
Fax: +264 61 255 207
Email: tkasinganeti@dpe.com.na

PERSONAL DETAILS

Name & Surname Djimu Djuta
Postal Address
Town Diogha Email 0814180154

What is your main area of interest regarding the proposed developments?

Electricity
network

Do you have any points of concern or support regarding the proposed projects?
If "yes", please briefly list these in point format:

NO

YES / NO

Do you wish this project to proceed?

YES / NO

Cedat

STAMP/SIGNATURE

REGISTRATION AND COMMENTS FORM

ENVIRONMENTAL AND SOCIAL MANAGEMENT PLAN: THE PROPOSED
TELECOMMUNICATION BASE TRANSCIVER STATION (BTS) TOWER AT DIYOGHA
SETTLEMENT IN, KAVANGO EAST REGION-NAMIBIA.

KINDLY COMPLETE THIS FORM IN DETAIL AND RETURN TO:

D&P Engineers and environmental consultants
Environmental Consultant: Tendai E. Kasinganeti
Phone: +264813634904
Fax: +264 61 255 207
Email: tkasinganeti@dpe.com.na

PERSONAL DETAILS

Name & Surname Mafetje, Christoph
Postal Address Email 0813783710
Town Diyoqha

What is your main area of interest regarding the proposed developments?

Electricity
Business
Networks
E-wallet

Do you have any points of concern or support regarding the proposed projects?
If "yes", please briefly list these in point format:

No

YES / NO

Do you wish this project to proceed?

YES / NO

Chrf.
STAMP/SIGNATURE

REGISTRATION AND COMMENTS FORM

ENVIRONMENTAL AND SOCIAL MANAGEMENT PLAN: THE PROPOSED
TELECOMMUNICATION BASE TRANSCIEVER STATION (BTS) TOWER AT DIYOGHA
SETTLEMENT IN, KAVANGO EAST REGION-NAMIBIA.

KINDLY COMPLETE THIS FORM IN DETAIL AND RETURN TO:

D&P Engineers and environmental consultants
Environmental Consultant: Tendai E. Kasinganeti
Phone: +264813634904
Fax: +264 61 255 207
Email: tkasinganeti@dpe.com.na

PERSONAL DETAILS

Name & Surname: Shashava Maricanus
Postal Address: 5210 Email: 081 66 77 959
Town: DIYOGHA

What is your main area of interest regarding the proposed developments?

Electricity
network
EWALLAT
FOR BUSINESS

Do you have any points of concern or support regarding the proposed projects?
If "yes", please briefly list these in point format:

YES / NO

NO

Do you wish this project to proceed?

YES / NO

HT
STAMP/SIGNATURE

REGISTRATION AND COMMENTS FORM

ENVIRONMENTAL AND SOCIAL MANAGEMENT PLAN: THE PROPOSED
TELECOMMUNICATION BASE TRANSCIEVER STATION (BTS) TOWER
SHIKOTO REGION, NAMIBIA.

KINDLY COMPLETE THIS FORM IN DETAIL AND RETURN TO:

D&P Engineers and environmental consultants
Environmental Consultant: Tendai E. Kasinganeti
Phone: +264813634904
Fax: +264 61 255 207
Email: tkasinganeti@dpe.com.na

PERSONAL DETAILS

Name & Surname Rusi Veronika Mutango
Postal Address N/A Email N/A
Town Diyagha

What is your main area of interest regarding the proposed developments?

It will bring electricity in the community.
Access to internet connection
Access to computer at school.

Do you have any points of concern or support regarding the proposed projects?
If "yes", please briefly list these in point format:

YES / NO

Do you wish this project to proceed?

YES / NO

STAMP/SIGNATURE

Rusi Mutango

REGISTRATION AND COMMENTS FORM

ENVIRONMENTAL AND SOCIAL MANAGEMENT PLAN: THE PROPOSED
TELECOMMUNICATION BASE TRANSCIEVER STATION (BTS) TOWER ~~XXXXXXXXXX~~
~~XXXXXXXXXX~~ -NAMIBIA.

KINDLY COMPLETE THIS FORM IN DETAIL AND RETURN TO:

D&P Engineers and environmental consultants
Environmental Consultant: Tendai E. Kasinganeti
Phone: +264813634904
Fax: +264 61 255 207
Email: tkasinganeti@dpe.com.na

PERSONAL DETAILS

Name & Surname HENDRICK K KASHAIKO
Postal Address DARTBETHA N/A Email 0818122189
Town Diyasib

What is your main area of interest regarding the proposed developments?

better communication
ACCESS TO WI-FI

Do you have any points of concern or support regarding the proposed projects?
If "yes", please briefly list these in point format:

YES / NO

Do you wish this project to proceed?

YES / NO

STAMP/SIGNATURE



REGISTRATION AND COMMENTS FORM

ENVIRONMENTAL AND SOCIAL MANAGEMENT PLAN: THE PROPOSED
TELECOMMUNICATION BASE TRANSCEIVER STATION (BTS) TOWER
[REDACTED] NAMIBIA.

KINDLY COMPLETE THIS FORM IN DETAIL AND RETURN TO:

D&P Engineers and environmental consultants
Environmental Consultant: Tendai E. Kasinganeti
Phone: +264813634904
Fax: +264 61 255 207
Email: tkasinganeti@dpe.com.na

PERSONAL DETAILS

Name & Surname Anastasia Thibaka
Postal Address
Town Diyogha Email 081 83 76563

What is your main area of interest regarding the proposed developments?

Faster Internetwork
Easy Communication

Do you have any points of concern or support regarding the proposed projects?
If "yes", please briefly list these in point format:

.....
.....
.....
.....
.....
.....

YES / NO

Do you wish this project to proceed?

YES / NO

STAMP/SIGNATURE
Thibaka

REGISTRATION AND COMMENTS FORM

ENVIRONMENTAL AND SOCIAL MANAGEMENT PLAN: THE PROPOSED
TELECOMMUNICATION BASE TRANSCEIVER STATION (BTS) TOWER
[REDACTED] NAMIBIA.

KINDLY COMPLETE THIS FORM IN DETAIL AND RETURN TO:

D&P Engineers and environmental consultants
Environmental Consultant: Tendai E. Kasinganeti
Phone: +264813634904
Fax: +264 61 255 207
Email: tkasinganeti@dpe.com.na

PERSONAL DETAILS

Name & Surname... Elisabeth Kevare
Postal Address... _____ Email... —
Town... Diyogha

What is your main area of interest regarding the proposed developments?

Internet will be faster
Video calls will be smoother.
Whatsapp will be faster

Do you have any points of concern or support regarding the proposed projects?
If "yes", please briefly list these in point format:

.....
.....
.....
.....
.....
.....

YES / NO

Do you wish this project to proceed?

YES / NO

STAMP/SIGNATURE
K E R

REGISTRATION AND COMMENTS FORM

ENVIRONMENTAL AND SOCIAL MANAGEMENT PLAN: THE PROPOSED
TELECOMMUNICATION BASE TRANSCIEVER STATION (BTS) TOWER
AT ABOLLEWA VILLAGE IN ZAMBESI REGION, NAMIBIA.

KINDLY COMPLETE THIS FORM IN DETAIL AND RETURN TO:

D&P Engineers and environmental consultants
Environmental Consultant: Tendai E. Kasinganeti
Phone: +264813634904
Fax: +264 61 255 207
Email: tkasinganeti@dpe.com.na

PERSONAL DETAILS

Name & Surname MAKAYI Elisabeth
Postal Address _____ Email _____
Town DIYOGHA

What is your main area of interest regarding the proposed developments?

Network connectivity will be stronger enough
 Whatsapp will be faster
 video call will be stronger

Do you have any points of concern or support regarding the proposed projects?
If "yes", please briefly list these in point format:

Network signal should be variable YES / NO

Do you wish this project to proceed?

YES / NO

STAMP/SIGNATURE

MU

REGISTRATION AND COMMENTS FORM

ENVIRONMENTAL AND SOCIAL MANAGEMENT PLAN: THE PROPOSED
TELECOMMUNICATION BASE TRANSCIVER STATION (BTS) TOWER
AT OROTELWA VILLAGE IN ZAMBEZI REGION, NAMIBIA.

KINDLY COMPLETE THIS FORM IN DETAIL AND RETURN TO:

D&P Engineers and environmental consultants
Environmental Consultant: Tendai E. Kasinganeti
Phone: +264813634904
Fax: +264 61 255 207
Email: tkasinganeti@dpe.com.na

PERSONAL DETAILS

Name & Surname Katarina maghambayi
Postal Address _____ Email _____
Town Diyogha

What is your main area of interest regarding the proposed developments?

- Internet download will be faster
- teleworking will be efficiency.

Do you have any points of concern or support regarding the proposed projects?
If "yes", please briefly list these in point format:

Network should not be poor in terms
of signals strength YES / NO

Do you wish this project to proceed?

YES / NO

STAMP/SIGNATURE

K. 11

REGISTRATION AND COMMENTS FORM

ENVIRONMENTAL AND SOCIAL MANAGEMENT PLAN: THE PROPOSED
TELECOMMUNICATION BASE TRANSCIVER STATION (BTS) TOWER
IN KABOTELWA VILLAGE IN ZAMBESI REGION, NAMIBIA.

KINDLY COMPLETE THIS FORM IN DETAIL AND RETURN TO:

D&P Engineers and environmental consultants
Environmental Consultant: Tendai E. Kasinganeti
Phone: +264813634904
Fax: +264 61 255 207
Email: tkasinganeti@dpe.com.na

PERSONAL DETAILS

Name & Surname fungencia KAVEYO
Postal Address _____ Email _____
Town Diyogha

What is your main area of interest regarding the proposed developments?

Phone calls will be improved if the
network tower will be installed

Do you have any points of concern or support regarding the proposed projects?
If "yes", please briefly list these in point format:

YES / NO

Do you wish this project to proceed?

YES / NO

STAMP/SIGNATURE

T.E.K.

REGISTRATION AND COMMENTS FORM

ENVIRONMENTAL AND SOCIAL MANAGEMENT PLAN: THE PROPOSED TELECOMMUNICATION BASE TRANSCIVER STATION (BTS) TOWER ~~AT~~ ~~KAKABOLELWA VILLAGE IN ZAMBESI REGION~~ NAMIBIA.

KINDLY COMPLETE THIS FORM IN DETAIL AND RETURN TO:

D&P Engineers and environmental consultants
Environmental Consultant: Tendai E. Kasinganeti
Phone: +264813634904
Fax: +264 61 255 207
Email: tkasinganeti@dpe.com.na

PERSONAL DETAILS

Name & Surname... Josephine Tenapo
Postal Address... _____ Email... _____
Town... Diyogha

What is your main area of interest regarding the proposed developments?

Phone calls will be smothery

Do you have any points of concern or support regarding the proposed projects?
If "yes", please briefly list these in point format:

YES / NO

Do you wish this project to proceed?

YES / NO

STAMP/SIGNATURE

M. E. N.

REGISTRATION AND COMMENTS FORM

ENVIRONMENTAL AND SOCIAL MANAGEMENT PLAN: THE PROPOSED
TELECOMMUNICATION BASE TRANSCIEVER STATION (BTS) TOWER
~~AKABOLELWA VILLAGE IN ZAMBEZI REGION~~ -NAMIBIA.

KINDLY COMPLETE THIS FORM IN DETAIL AND RETURN TO:

D&P Engineers and environmental consultants
Environmental Consultant: Tendai E. Kasinganeti
Phone: +264813634904
Fax: +264 61 255 207
Email: tkasinganeti@dpe.com.na

PERSONAL DETAILS

Name & Surname patricia keware
Postal Address _____ Email _____
Town Diyoona

What is your main area of interest regarding the proposed developments?

phone calls will be clear
internet connection will be great

Do you have any points of concern or support regarding the proposed projects?
If "yes", please briefly list these in point format:

YES / NO

Do you wish this project to proceed?

YES / NO

STAMP/SIGNATURE

K. P. P

REGISTRATION AND COMMENTS FORM

ENVIRONMENTAL AND SOCIAL MANAGEMENT PLAN: THE PROPOSED TELECOMMUNICATION BASE TRANSCIVER STATION (BTS) TOWER ~~AT KAPOLELWA VILLAGE IN ERARUZI REGION~~ - NAMIBIA.

KINDLY COMPLETE THIS FORM IN DETAIL AND RETURN TO:

D&P Engineers and environmental consultants
Environmental Consultant: Tendai E. Kasinganeti
Phone: +264813634904
Fax: +264 61 255 207
Email: tkasinganeti@dpe.com.na

PERSONAL DETAILS

Name & Surname... Kunyanya Mudhumbi
Postal Address.....
Town... Diyosha..... Email _____

What is your main area of interest regarding the proposed developments?

- our internet will be strong enough
- internet will be stronger.

Do you have any points of concern or support regarding the proposed projects?
If "yes", please briefly list these in point format:

Internet whatsapp YES / NO
video calls will be great

Do you wish this project to proceed?

YES / NO

STAMP/SIGNATURE

REGISTRATION AND COMMENTS FORM

ENVIRONMENTAL AND SOCIAL MANAGEMENT PLAN: THE PROPOSED
TELECOMMUNICATION BASE TRANSCIVER STATION (BTS) TOWER
KAKABOLELWA VILLAGE IN ZAMBESI REGION, NAMIBIA.

KINDLY COMPLETE THIS FORM IN DETAIL AND RETURN TO:

D&P Engineers and environmental consultants
Environmental Consultant: Tendai E. Kasinganeti
Phone: +264813634904
Fax: +264 61 255 207
Email: tkasinganeti@dpe.com.na

PERSONAL DETAILS

Name & Surname: Sandrina Thinaya Muyevu
Postal Address: N/A Email: 0812796521
Town: Nyagha

What is your main area of interest regarding the proposed developments?

- # Fast Internet Connection
- # Fast Sending money to the families who are far away
- # Access to Education e.g. I.C.T
- # It will bring Electricity in the Community

Do you have any points of concern or support regarding the proposed projects?
If "yes", please briefly list these in point format:

YES / NO

Do you wish this project to proceed?

YES / NO

STAMP/SIGNATURE

Sandrina

REGISTRATION AND COMMENTS FORM

ENVIRONMENTAL AND SOCIAL MANAGEMENT PLAN: THE PROPOSED
TELECOMMUNICATION BASE TRANSCIEVER STATION (BTS) TOWER **ST. JULYOKA**
VILLAGE, OSHIKOTO REGION, NAMIBIA

KINDLY COMPLETE THIS FORM IN DETAIL AND RETURN TO:

D&P Engineers and environmental consultants
Environmental Consultant: Tendai E. Kasinganeti
Phone: +264813634904
Fax: +264 61 255 207
Email: tkasinganeti@dpe.com.na

PERSONAL DETAILS

Name & Surname Bimbindo Arriam M
Postal Address N/A Email 0818515744
Town Saxena

What is your main area of interest regarding the proposed developments?

Faster internet network
Easy communications

Do you have any points of concern or support regarding the proposed projects?
If "yes", please briefly list these in point format:

YES / NO

Do you wish this project to proceed?

YES / NO

STAMP/SIGNATURE

[Handwritten Signature]

REGISTRATION AND COMMENTS FORM

ENVIRONMENTAL AND SOCIAL MANAGEMENT PLAN: THE PROPOSED
TELECOMMUNICATION BASE TRANSCIVER STATION (BTS) TOWER AT ~~ONYOMA~~
~~SETTLEMENT IN KAVANGO REGION~~ NAMIBIA.

KINDLY COMPLETE THIS FORM IN DETAIL AND RETURN TO:

D&P Engineers and environmental consultants
Environmental Consultant: Tendai E. Kasinganeti
Phone: +264813634904
Fax: +264 61 255 207
Email: tkasinganeti@dpe.com.na

PERSONAL DETAILS

Name & Surname Dinyanda B.
Postal Address..... Email 0818126338
Town Diyogha

What is your main area of interest regarding the proposed developments?

We want the Network for internet access

Do you have any points of concern or support regarding the proposed projects?
If "yes", please briefly list these in point format:

YES / NO

Do you wish this project to proceed?

YES / NO

STAMP/SIGNATURE

Bony!

REGISTRATION AND COMMENTS FORM

ENVIRONMENTAL AND SOCIAL MANAGEMENT PLAN: THE PROPOSED
TELECOMMUNICATION BASE TRANSCIVER STATION (BTS) TOWER
KAKABOLELWA VILLAGE IN ZAMBESI REGION, NAMIBIA.

KINDLY COMPLETE THIS FORM IN DETAIL AND RETURN TO:

D&P Engineers and environmental consultants
Environmental Consultant: Tendai E. Kasinganeti
Phone: +264813634904
Fax: +264 61 255 207
Email: tkasinganeti@dpe.com.na

PERSONAL DETAILS

Name & Surname: Matende Venansia Karowa
Postal Address: N/A Email: 0816901987
Town: Diyogha

What is your main area of interest regarding the proposed developments?

There is good idea to bring a tower at our village because
We will have a benefit of nearby electricity.

Fast internet and access to education.

Do you have any points of concern or support regarding the proposed projects?
If "yes", please briefly list these in point format:

YES / NO

Do you wish this project to proceed?

YES / NO

STAMP/SIGNATURE

[Signature]

REGISTRATION AND COMMENTS FORM

ENVIRONMENTAL AND SOCIAL MANAGEMENT PLAN: THE PROPOSED
TELECOMMUNICATION BASE TRANSCEIVER STATION (BTS) TOWER
~~AT OUBELWA VILLAGE IN ZAMBESI REGION~~ NAMIBIA.

KINDLY COMPLETE THIS FORM IN DETAIL AND RETURN TO:

D&P Engineers and environmental consultants
Environmental Consultant: Tendai E. Kasinganeti
Phone: +264813634904
Fax: +264 61 255 207
Email: tkasinganeti@dpe.com.na

PERSONAL DETAILS

Name & Surname... Mekwathi Maithe
Postal Address.....
Town..... Siyogha Email 086621227

What is your main area of interest regarding the proposed developments?

- faster internet network
- faster whatsapp network
- easy to call

Do you have any points of concern or support regarding the proposed projects?
If "yes", please briefly list these in point format:

YES / NO

Do you wish this project to proceed?

YES / NO

STAMP/SIGNATURE



REGISTRATION AND COMMENTS FORM

ENVIRONMENTAL AND SOCIAL MANAGEMENT PLAN: THE PROPOSED
TELECOMMUNICATION BASE TRANSCIVER STATION (BTS) TOWER AT DIYOGHA
SETTLEMENT IN, KAVANGO EAST REGION-NAMIBIA.

KINDLY COMPLETE THIS FORM IN DETAIL AND RETURN TO:

D&P Engineers and environmental consultants
Environmental Consultant: Tendai E. Kasinganeti
Phone: +264813634904
Fax: +264 61 255 207
Email: tkasinganeti@dpe.com.na

PERSONAL DETAILS

Name & Surname..... *DISHO V T*
Postal Address..... Email *081498645*
Town..... *DIYOGHA*

What is your main area of interest regarding the proposed developments?

.....
..... *we need to do more than business*
..... *net work and attend*
.....
.....

Do you have any points of concern or support regarding the proposed projects?
If "yes", please briefly list these in point format:

.....
.....
.....
.....
.....
.....
.....
.....
.....
.....

YES / NO

Do you wish this project to proceed?

YES / NO

STAMP/SIGNATURE

Disho

REGISTRATION AND COMMENTS FORM

ENVIRONMENTAL AND SOCIAL MANAGEMENT PLAN: THE PROPOSED
TELECOMMUNICATION BASE TRANSCIVER STATION (BTS) TOWER
REGION-NAMIBIA.

KINDLY COMPLETE THIS FORM IN DETAIL AND RETURN TO:

D&P Engineers and environmental consultants
Environmental Consultant: Tendai E. Kasinganeti
Phone: +264813634904
Fax: +264 61 255 207
Email: tkasinganeti@dpe.com.na

PERSONAL DETAILS

Name & Surname Thitaker H
Postal Address Diyappa Email 0814236243
Town Diyappa

What is your main area of interest regarding the proposed developments?

we need the social medium and
fast net work and
business and more more project

Do you have any points of concern or support regarding the proposed projects?
If "yes", please briefly list these in point format:

YES / NO

Do you wish this project to proceed?

YES / NO

STAMP/SIGNATURE

Heleng

Appendix B:

Maps and Layouts

- 1. Locality Map**
- 2. Layout Plan**

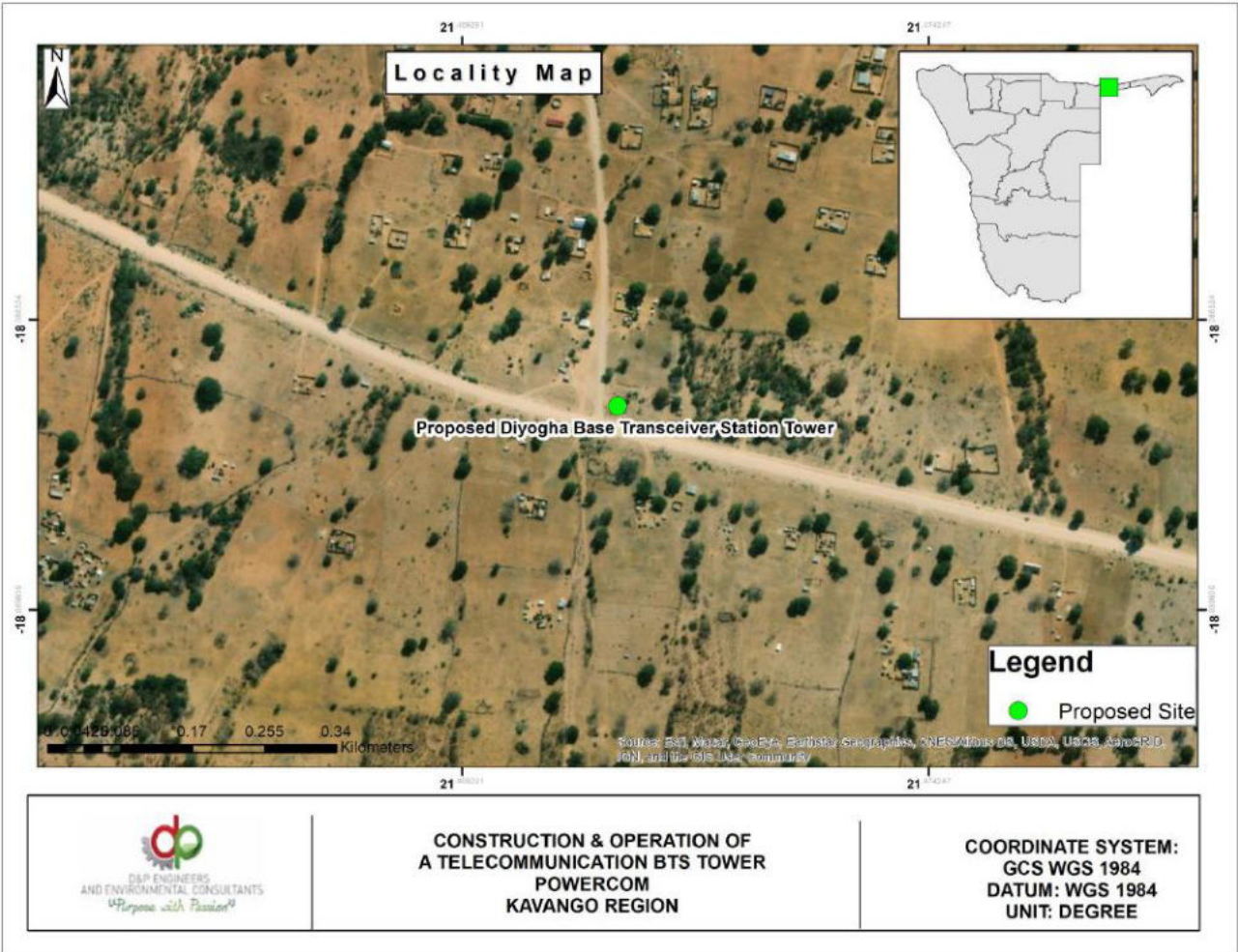

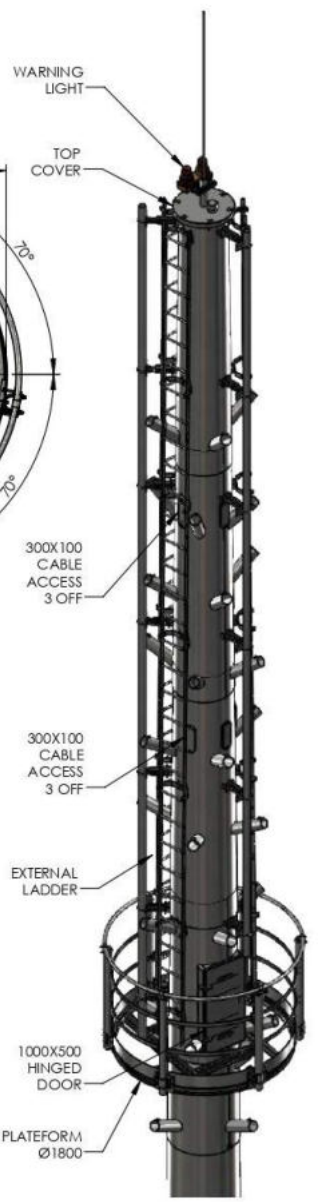
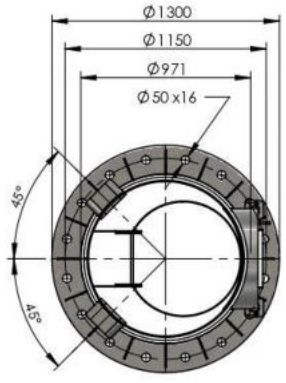
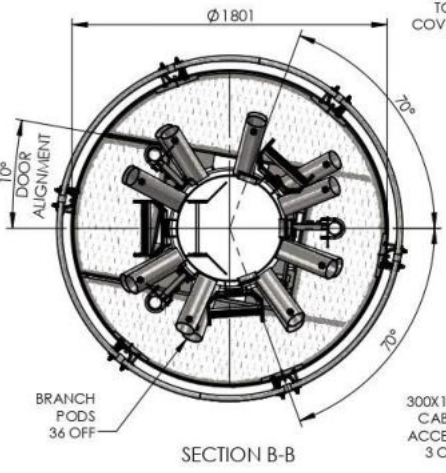
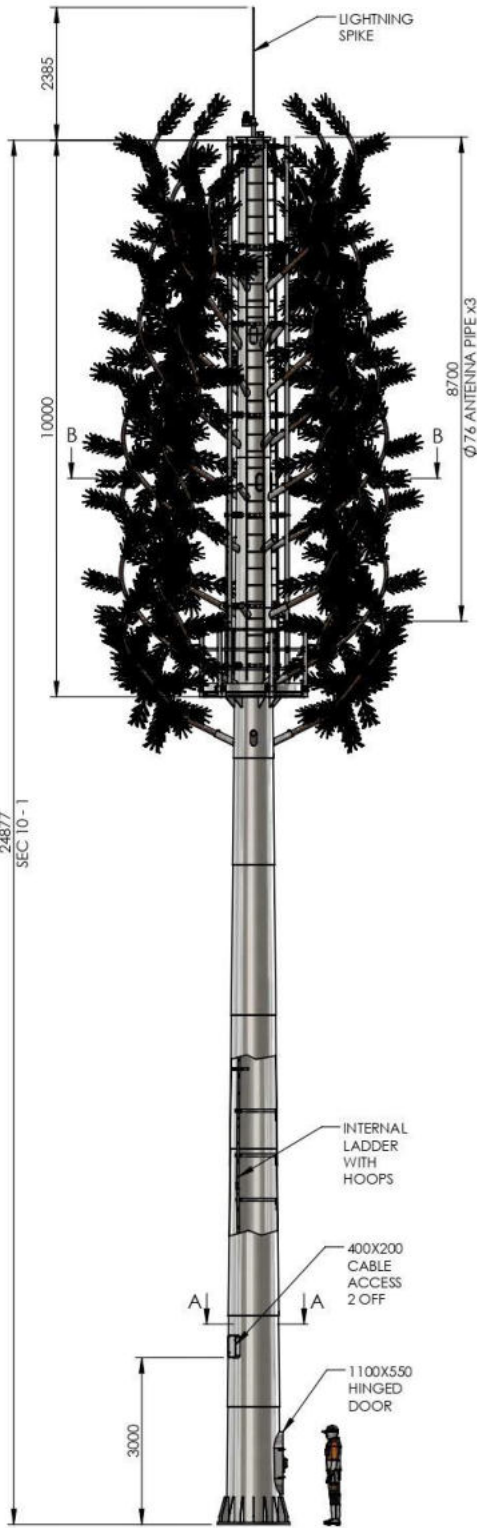

0		TLF	2020/09/14
REV	DESCRIPTION	DRAWN	DATE
DESIGN REFERENCE:			
Sectional Poles <small>SINCE 1960</small>		UNLESS STATED OTHERWISE, DIMENSIONS IN mm DO NOT SCALE	
		DIMENSIONS 0-1m ±0.5mm 1-3m ±1.0mm	
TITLE: 25m CT PINE WITH 10m PLATFORM & 3X 8m ANTENNA PIPES		ANGLES ±2°	
DRW NO: ILG25PI-10PL-TV10B-UNV-R0		SHEET: 1 OF 1	
CLIENT:			

Appendix C: Land Tenure, Approvals and Licenses

- 1. Proof of Land Ownership/
Authorisation for
development/ Consent for
Development**



KAVANGO EAST REGIONAL COUNCIL

MUKWE CONSTITUENCY OFFICE

Enquiries: maghambayi@gmail.com
Fax: 0886560093 / 258367
Tel: +264 66 258 398 / 395

KARATJA / DIVUNDU

P.O. Box 5105
Divundu, Namibia

Date: 8 December 2021

OFFICE OF THE REGIONAL COUNCILOR

The CEO
Powercom Pty Ltd
P.O. BOX 40799
WINDHOEK

Attention: Kennedy Matomola,

Subject: **ERECTION MTC TOWER IN MUKWE CONSTITUENCY AT KANGONGO AND DIYOGHA VILLAGE IN MUKWE CONSTITUENCY**

1. Reference is made to the consultative visit by your office led by Mr. Kennedy Motomola at the Hambukushu Traditional Authority with Fumu Erwin Munika Mbambo on Monday, 6 December 2021 regarding the allocation of land to erect the MTC tower as part of the requirements by the Communal Land Board.
2. Kindly be informed that the Hambukushu Traditional Authority has in principle allocated the identified land at Diyogha and Kangongo Vilage for the tower to be erected after I have consulted the Fumu on Wednesday, 8 December 2021 together with the two Headman Mr. Erwin Disho of Kangongo Village and Mr. Konrad Mbote of Diyogha.
3. That your office is requested to submit a written application for the envisage project to the Hambukushu Traditional Authority, whereby the Traditional Authority will issue you with a consent letter as per their requirements. Please do this through my office without delay
4. My office whole heartedly appreciates this development and I am looking forward for the total implementation of this project. Do not hesitate to contact me at 0811502612 or maghambayi@gmail.com

Thank you for your usual cooperation and support

Yours Sincerely

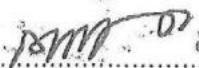
Damian M Maghambayi (Hon)
REGIONAL COUNCILOR



All official correspondence must be addressed to the Regional Councillor Mukwe Constituency

Appendix D:

EIA Team Resumes

- 1. Mr. Tendai E. Kasinganeti**
- 2. Ms. Shiwayu Kristian NN**

Curriculum Vitae (CV) for Tendai. Kasinganeti

1. **Proposed Position:** Environmental Assessment Practitioner
2. **Name of Firm** D&P Engineers and Environmental consultants
3. **Name of Staff** Evidence Tendai Kasinganeti
4. **Date of Birth:** 27 November 1991 **Nationality:** Zimbabwean
5. Education:

Name of University or institution, location, dates attended (year from – year to)	Degree(s)/diploma(s) obtained
Midlands State University, Zimbabwe (11/12011 – 05/2015)	BSc Hons. Geography and Environmental Science Thesis „Spatial and temporal analysis of base transceiver stations development and associated environmental impacts (Zimbabwe)
National University of Science and Technology 2018-2020 (Ongoing)	Master of Geoinformation Science and Earth Observation (Natural Resources Management)

-
6. **Membership of Professional Associations:**
 - Environmental Assessment Professionals of Namibia (EAPAN)
 - International Association for Impact Assessment (IAIA)
-

7. **Other Training:**

Further education:

- Certificate on Going Green for Social Entrepreneurs (Young African Leaders Initiative Network, USA, 2016)
 - Fundamentals of Health and Safety in the Workplace (Allison International, Ireland, 2016)
 - Introduction to Ecosystem Service Valuation and Policy Design (RESMOB Namibia, 2018)
-

8. **Countries of Work Experience:**

- Namibia
- Zimbabwe
- Mozambique

9. **Languages:**

Language	Reading	Speaking	Writing
English	excellent	excellent	Excellent

10. **Employment Record:**

Employment record relevant to the assignment:		
Period	Employing organization and your title/position. Contact info for references	Summary of activities performed relevant to the Assignment

CURRICULUM VITAE Tendai E. Kasinganeti (*Environmental Expert (Backstopper)*)

April 2018 to date	<p>Environmental Practitioner and Consultant</p> <p>Mr. Timo David Director: Project Management D&P Engineers and Environmental Consultants E: tdavid@dpe.com.na</p>	<ul style="list-style-type: none"> ▪ GIS mapping and Environmental Sensitivity mapping. ▪ Providing professional consulting services to clients in Namibia with focus on EIAs, EMPs reporting and compliance advisory. ▪ Conducting Environmental Scoping Assessments and Environmental Management Plans ▪ Application for Environmental Clearance Certificates ▪ Environmental Control for projects during construction and operation. ▪ Environmental Quarterly and Biannual reporting ▪ Environmental monitoring and compliance auditing.
January 2016 to April 2018	<p>Environmental Planner</p> <p>Mr. Henry Krohne Director-Plan Africa Consulting E: pafrica@mweb.com.na</p>	<ul style="list-style-type: none"> ▪ Coordinating and managing Environmental Impact Assessment Studies: ▪ Environmental Reports writing. ▪ Conducting Bio-Physical studies. ▪ Stakeholder engagement and consultation ▪ Environmental Monitoring and Auditing ▪ Land use Mapping and GIS
July 2013 to December 2015	<p>-Student intern -Junior Environmental and Spatial Consultant</p> <p>Mr. Anesu Mudiwa Director: Nwas Environmental Consulting E: anesu@nwas.co.zw W: www.nwas.co.zw</p>	<ul style="list-style-type: none"> ▪ Occupational Health, Safety and Environmental Management ▪ Baseline surveys for EIA projects (Social, ecological, economic and political impact Assessment) ▪ Compiling Environmental and Social Impact Assessment Reports for different projects ▪ Public and Stakeholder consultation ▪ Environmental Compliance Auditing and Quarterly Reports ▪ Soil and water samples processing (Sample collecting, sending for lab tests and interpretation of results) ▪ Emissions testing

<p>11. Detailed Tasks Assigned</p> <ul style="list-style-type: none"> • Stakeholders Engagement • Legislative Frameworks Review • Environmental Compliance Manual and Guidelines Development • Team Leader Backstopper 	<p>12. Work Undertaken that Best Illustrates Capability to Handle the Tasks Assigned</p> <p><i>[Among the assignments in which the staff has been involved, indicate the following information for those assignments that best illustrate staff capability to handle the tasks listed under point 11.]</i></p> <p>Name of assignment or project: Environmental Management Plans development</p> <p>Year: 2017/18</p> <p>Location: Namibia (All Regions) -56 Fuel Retail facilities</p> <p>Client: Engen Namibia/ Nam-Geo Enviro Solutions</p> <p>Main project features:</p> <ul style="list-style-type: none"> • EHS Auditing • Environmental Management Plans Development • Application for Environmental Clearance Certificates for service stations (New application/ Renewals) • Develop EHS monitoring and compliance schedule • Conduct site risk assessment and recommend corrective action plan <hr/> <p>Name of assignment or project: Namibia Water Support Programme</p>
---	---

CURRICULUM VITAE **Tendai E. Kasinganeti** (*Environmental Expert (Backstopper)*)

	<p>Year: 2019</p> <p>Location: Namibia (All Regions)</p> <p>Client: Ministry of Agriculture Water and Forestry/ African Development Bank</p> <p>Main project features:</p> <ul style="list-style-type: none"> • Strategic Environmental and Social Assessment/ Strategic Environmental and Social Management Framework • Environmental Compliance Guidelines for implementing the Namibia Water Sector Support Programme <p>Positions held: Environmental and Social Assessment Expert_</p> <p>Activities performed:</p> <ul style="list-style-type: none"> • Stakeholders Consultation • Regional Workshops • Baseline Environmental Scoping Assessment • Institutional Capability and Needs Assessment for Environmental Compliance • Strategic Environmental and Social Assessment Development (SESA) • Strategic Environmental and Social Management Framework (ESMF) • ESMF Workshop and Compliance Training
	<p>Name of assignment or project: Etunda Feedlot</p> <p>Year: 2019</p> <p>Location: Etunda, Omusati Region-Namibia</p> <p>Client: Ministry of Agriculture Water and Forestry/ European Union</p> <p>Main project features:</p> <ul style="list-style-type: none"> • Environmental and Social Impact Assessment (ESIA)/ Environmental and Social Management Plan (ESMP) <p>Positions held: Environmental and Social Assessment Expert_</p> <p>Activities performed:</p> <ul style="list-style-type: none"> • Environmental Scoping Assessment • National, Regional and International Legal Frameworks Review • Public and Stakeholders Consultation • Groundwater Impact Assessment • Sensitivity Mapping • Environmental and Social Management Plan Development
	<p>Name of assignment or project: Le'Monte Village Development (Township Establishment and Incorporation)</p> <p>Year: 2018</p> <p>Location: Grootfontein, Otjozondjupa Region-Namibia</p> <p>Client: Singleton Commercial Pty Ltd</p>

CURRICULUM VITAE **Tendai E. Kasinganeti** (*Environmental Expert (Backstopper)*)

	<p>Main project features:</p> <ul style="list-style-type: none"> • Environmental and Social Impact Assessment (ESIA)/ Environmental and Social Management Plan (ESMP) <p>Positions held: Environmental and Social Assessment Expert_</p> <p>Activities performed:</p> <ul style="list-style-type: none"> • Environmental Scoping Assessment • National, Regional and International Legal Frameworks Review • Public and Stakeholders Consultation • Groundwater Impact Assessment • Sensitivity Mapping • Environmental and Social Management Plan Development
--	---

ADDITIONAL PROJECTS EXPERIENCES

Client, Year and Country	Project Name and Deliverable
GIZ and Ministry of Agriculture Water and Land Reform, 200-21-Namibia	Flexible Land Tenure System: Environmental and Social Management and Compliance Guideline Manual for the Flexible Land Tenure Implementation
Centre for Natural Resources Governance, 2020-21- Zimbabwe and Zambia	Coal mining and thermal power generation in Sengwa-Kariba areas Zimbabwe: Environmental and Social Impact Assessment-Focus on Environmental Rights and Gender impacts
European Union and Ministry of Agriculture, Water and Forestry, 2020-Namibia	Program to improve livestock efficiency and marketability in the Northern Communal Areas (NCAs) of Namibia: Various Environmental and Social Impact Assessments for specific projects
UNDP Namibia and Ministry of Mines and Energy, 2020-Namibia	Supporting livelihoods through small-scale mining of semi-precious stones, metals and minerals: Environmental, Health, Safety and Social Guidelines for Small Scale Miners in Namibia
AfDB and Ministry of Agriculture, Water and Forestry, 2019-Namibia	Namibia Water Sector Support Programme: Strategic Environmental and Social Assessment and Environmental and Social Management Framework
Keetmanshoop Medical Practice, 2018-Namibia	Keetmanshoop Private Hospital: Environmental and Social Impact Assessment.
Anpro Hides and Skins, 2018-Namibia	Anpro animal rendering plant and tannery: Environmental Impact Assessment

13. Certification:

I, the undersigned, certify that to the best of my knowledge and belief, this CV correctly describes myself, my qualifications, and my experience. I understand that any wilful misstatement described herein may lead to my disqualification or dismissal, if engaged.



[Signature of staff member or authorized representative of the staff] Date: 19-May-21
Day/Month/Year

Full name of authorized representative: Evidence Tendai Kasinganeti

KRISTIAN NDIIPANDA NDEKUPANDA SHIWAYU
ENVIRONMENTAL SCIENTIST
KRISTIAN SHIWAYU | LINKEDIN
LICENSE: LEARNER'S LICENSE

Name of Expert:	Shiwayu Kristian NN
Date of Birth:	03/01/1993
Country of Citizenship/Residence	Namibian Residence

1. Education:

ACADEMIC QUALIFICATIONS		
Name of Course	Institution	Year conferred
International General Certificate in Occupational Health and Safety Practice	NEBOSH	Ongoing
BSc Hons. Integrated Environmental Science	University of Namibia	2019
Master of Science in Integrated Environmental Science and Sustainable Development	The International University of Management	Ongoing

3. Employment Record:

Period	Employing organization and your title/position. Contact info for references	Country	Summary of activities performed relevant to the Assignment
Sept 2022 to date	-Intern: Environmental & Sustainability Consultant Mr. Timo David Director: Project Management D&P Engineers and Environmental Consultants E: tdavid@dpe.com.na	Namibia	<ul style="list-style-type: none"> ▪ Providing professional consulting services to clients in Namibia with focus on EIAs, EMPs reporting and compliance advisory. ▪ Conducting Environmental Scoping Assessments and Environmental Management Plans ▪ Application for Environmental Clearance Certificates

Jan 2021 to May 2022	<p>-Student Employment: Centre for Environmental Studies</p> <p>Mr Sioni Iikela</p> <p>Director: CES, IUM</p> <p>E: s.iikela@ium.edu.na</p> <p>W: 061 433 6412</p>	Namibia	<ul style="list-style-type: none"> ▪ Customer Service ▪ To assist the Centre director, and lecturing staff with all related functions and relevant logistical matters. ▪ Administrative functions ▪ Research
Oct 2020 to Jan 2021	<p>-Graduate Intern: Wildlife and National Parks Division</p> <p>Mr. J Amutenya</p> <p>Chief Warden (Central)</p> <p>Ministry of Environmental, forestry & Tourism (Windhoek)</p> <p>E: jeremia.amutenya@gmail.com</p> <p>W: +26481 0415182</p>	Namibia	<ul style="list-style-type: none"> ▪ Office administrative functions ▪ Law enforcement ▪ Human Wildlife Management ▪ CBNRM (Community Based Natural Resource Management) ▪ Research and Monitoring ▪ Ensure the sustainable utilization of wildlife within central areas of Namibia.
July 2020 to Sept 2020	<p>-Researcher</p> <p>Namibia Research Institution (Gobabeb)</p>	Namibia	<ul style="list-style-type: none"> ▪ Data processing and analyses ▪ Survey techniques ▪ Scientific presentations, while emphasizing teamwork ▪ Critical thinking ▪ Problem-solving skills
Aug 2019 to Sept 2019	<p>-Researcher/Enumerator</p> <p>Namibia agricultural Mechanisation and Seed Improvement Project (NAMSIP)</p>	Namibia	<ul style="list-style-type: none"> ▪ Interviewed farmers in Oshikoto Region ▪ Data collection ▪ Enter data collection in Microsoft Excel for data analyses.
Dec 2017 to Jan 2018	<p>-Field Attachment: Wildlife and National Parks Division</p> <p>Ministry of Environmental, forestry & Tourism (Windhoek)</p>	Namibia	<ul style="list-style-type: none"> ▪ Office administrative functions ▪ Law enforcement ▪ Human Wildlife Management ▪ CBNRM (Community Based Natural Resource Management) ▪ Research and Monitoring ▪ Ensure the sustainable utilization of wildlife within central areas of Namibia.
Dec 2016 to Jan 2017	<p>-Field Attachment: Environmental Officer</p> <p>Tschudi Copper Mine</p>	Namibia	<ul style="list-style-type: none"> ▪ Administration functions ▪ Conducted air quality monitoring ▪ Environmental inspection ▪ Data capturing ▪ Minute taking at the interested and affected parties.

4. **Membership of Professional Associations:**

- Recycle Namibia Forum

5. **Countries of Work Experience:** Namibia (SADC Region)

6. **Languages:**

	<u>Speaking</u>	<u>Reading</u>	<u>Writing</u>
English	Good	Good	Good

7. **Projects Conducted**

Tasks Assigned	Work Undertaken
Biodiversity Report	<p>Name of Assignment or Project: Biodiversity Report for Namibia Uranium (PTY) LTD, EPL 7297.</p> <p>Year: 2021</p> <p>Location: Erongo Region</p> <p>Client: Uranium (PTY) LTD</p> <p>Main project features: Environmental and Biodiversity Impact Assessment</p> <p>Position Held: Biodiversity Specialist</p> <p>Activities performed: Biodiversity Assessment.</p>
D1-Inception Report & Workplan D2-Scoping Report D3-DESIA & ESMP Report D4-ECC Application	<p>Name of Assignment or Project: Biodiversity report for the proposed Erongo substation and associate infrastructure in Karibib Erongo Region, Namibia.</p> <p>Year: 2021</p> <p>Location: Karibib Erongo Region</p> <p>Client: Nampower</p> <p>Main project features: Environmental and Biodiversity Impact Assessment</p> <p>Position Held: Biodiversity Specialist</p> <p>Activities performed: Biodiversity Assessment.</p>

Tasks Assigned	Work Undertaken
D1-Inception Report & Workplan D2-Scoping Report D3-DESIA & ESMP Report D4-ECC Application	<p>Name of Assignment or Project: The Proposed Construction And Operation Of 22 Telecommunication Base Transceiver Station (Bts) Towers Countrywide-Namibia.</p> <p>Year: 2022</p> <p>Location: Country-wide</p> <p>Client: POWERCOM</p> <p>Main project features: Environmental and Social Impact Assessment and Environmental and Social Management Plan.</p> <p>Position Held: Environmentalist</p> <p>Activities performed: Environmental Impact Assessment, Environmental Management plan, Public and Stakeholders Consultation, Reports Drafting and Client liaison</p>

REPUBLIC OF NAMIBIA
NATIONAL IDENTITY CARD



930103 0062 7



SURNAME
SHIWAYU
FIRST NAME(S)
KRISTIAN NDIIPANDA
NDEKUPANDA

K. Shiwayu

NAMIBIAN POLICE

ONGWEDIVA

11-06-2020

CHARGE OFFICE

*... of the original which was examined by me and
... from my observations. The original has not
... been altered in any manner.*

*K. Shiwayu
Sindisa Lomb*

DATE OF BIRTH
1993-01-03

CITIZENSHIP
CITIZEN

RESIDENCE
OSHAKATI

SEX AND HEIGHT
FEMALE 1,60

HAIR COLOUR
BROWN

DATE OF ISSUE
2012-02-28

NOTE NO.
V89675



93010300627