

Appendix A: Public Consultation Documents

- 1. Newspaper adverts**
- 2. Consultation Register**
- 3. Questionnaire**
- 4. Communiques**



**NOTIFICATION AND CALL FOR PUBLIC PARTICIPATION
ENVIRONMENTAL IMPACT ASSESSMENT (EIA) PROCESS FOR THE PROPOSED DEVELOPMENT OF 22
TELECOMMUNICATION BASE-TRANSCIVER STATION (BTS) TOWERS ON SELECTED SITES COUNTRYWIDE, NAMIBIA**

D & P Engineers and Environmental Consultants hereby gives notice to all potentially interested and Affected Parties (I&AP) that an application will be made to the Environmental Commissioner in terms of the Environmental Management Act (No 7 of 2007) and the Environmental Impact Assessment Regulations (GN 30 of 6 February 2012) for the proposed development of twenty two (22) base transceiver station (BTS) towers.

Powercom (PTY) LTD herein referred to as the proponent has identified different areas that needs improved communication alternatives in Namibia due to growth in population and economic activities. To achieve the objective of improved telecommunication connectivity, Powercom has been appointed by Telecom Namibia its sister company to establish telecommunication towers across the identified different locations. In this respect, Powercom has identified sites to construct and operate 22 telecommunication base transceiver station towers across the country.

Powercom (the proponent) has appointed D&P Engineers and Environmental Consultants to conduct the EIA process for these proposed BTS tower developments. The EIA is being conducted to satisfy the Namibian environmental legislative requirements. The general public as well as any interested and Affected Parties (I&AP) are hereby invited to register their concerns and notify the consultant of any potential environmental and social impacts that may be triggered by the project.

The proposed projects for which the Environmental Clearance Certificates will be applied for are as follows:

<p>1. Project Title: Environmental Impact Assessment (EIA) Study for the Proposed Construction and Operation of a Telecommunication Base Transceiver Station (BTS) Tower at Seehelm Settlement in Eraras Region.</p> <p>Location: Seehelm Settlement, Eraras Region - Namibia</p> <p>Coordinates: 26°49'02.8"S, 17°48'11.5"E</p>	<p>2. Project Title: Environmental Impact Assessment (EIA) Study for the Proposed Construction and Operation of a Telecommunication Base Transceiver Station (BTS) Tower at Ohango Village in Oshana Region.</p> <p>Location: Ohango Village, Oshana Region - Namibia</p> <p>Coordinates: 18°02'21.8"S 16°19'24.7"E</p>	<p>Project Title: Environmental Impact Assessment (EIA) Study for the Proposed Construction and Operation of a Telecommunication Base Transceiver Station (BTS) Tower at Otshandja Village in Oshana Region.</p> <p>Location: Otshandja Village in Oshana Region - Namibia</p> <p>Coordinates: 17°59'28.0"S 15°38'17.3"E</p>	<p>Project Title: Environmental Impact Assessment (EIA) Study for the Proposed Construction and Operation of a Telecommunication Base Transceiver Station (BTS) Tower at Otshokolo Village in, Omusati Region.</p> <p>Location: Otshokolo Village in, Omusati Region - Namibia</p> <p>Coordinates: 17°32'15.9"S 15°07'42.2"E</p>
<p>Project Title: Environmental Impact Assessment (EIA) Study for the Proposed Construction and Operation of a Telecommunication Base Transceiver Station (BTS) Tower at Ovaherero Border Post, Omusati Region.</p> <p>Location: Ovaherero Border Post, Omusati Region - Namibia</p> <p>Coordinates: 17°25'05.0"S 14°34'07.8"E</p>	<p>Project Title: Environmental Impact Assessment (EIA) Study for the Proposed Construction and Operation of a Telecommunication Base Transceiver Station (BTS) Tower at Epanga Village, Oshana Region.</p> <p>Location: Epanga Village, Oshana Region - Namibia</p> <p>Coordinates: 17°24'37.5"S 16°26'14.7"E</p>	<p>Project Title: Environmental Impact Assessment (EIA) Study for the Proposed Construction and Operation of a Telecommunication Base Transceiver Station (BTS) Tower at Mupini Village in, Kavango West Region.</p> <p>Location: Mupini Village in, Kavango West Region - Namibia</p> <p>Coordinates: 17°52'48.6"S 19°37'52.4"E</p>	<p>Project Title: Environmental Impact Assessment (EIA) Study for the Proposed Construction and Operation of a Telecommunication Base Transceiver Station (BTS) Tower at Kangongo Village in, Kavango East Region.</p> <p>Location: Kangongo Village in, Kavango East Region - Namibia</p> <p>Coordinates: 17°57'01.7"S 21°09'52.5"E</p>
<p>Project Title: Environmental Impact Assessment (EIA) Study for the Proposed Construction and Operation of a Telecommunication Base Transceiver Station (BTS) Tower at Gulnas, Oshana Region.</p> <p>Location: Gulnas, Oshana Region - Namibia</p> <p>Coordinates: 20°14'52.4"S 17°20'53.9"E</p>	<p>Project Title: Environmental Impact Assessment (EIA) Study for the Proposed Construction and Operation of a Telecommunication Base Transceiver Station (BTS) Tower at Hamuse Village in, Zambezi Region.</p> <p>Location: Hamuse Village, Zambezi Region - Namibia</p> <p>Coordinates: 17°47'28.8"S 14°36'56.9"E</p>	<p>Project Title: Environmental Impact Assessment (EIA) Study for the Proposed Construction and Operation of a Telecommunication Base Transceiver Station (BTS) Tower at Dobra Brakwater in, Eraras Region.</p> <p>Location: Dobra Brakwater in, Eraras Region - Namibia</p> <p>Coordinates: 22°57'07.1"S 17°05'37.6"E</p>	<p>Project Title: Environmental Impact Assessment (EIA) Study for the Proposed Construction and Operation of a Telecommunication Base Transceiver Station (BTS) Tower at Howobees 51 in, Eraras Region.</p> <p>Location: Howobees Settlement, Eraras Region - Namibia</p> <p>Coordinates: 26°48'02.9"S, 17°48'11.5"E</p>
<p>Project Title: Environmental Impact Assessment (EIA) Study for the Proposed Construction and Operation of a Telecommunication Base Transceiver Station (BTS) Tower at Uuyoka village, Oshana Region.</p> <p>Location: Uuyoka village, Oshana Region - Namibia</p> <p>Coordinates: 17°57'24.7"S 16°18'39.1"E</p>	<p>Project Title: Environmental Impact Assessment (EIA) Study for the Proposed Construction and Operation of a Telecommunication Base Transceiver Station (BTS) Tower at Uunavuya Village in, Oshana Region.</p> <p>Location: Uunavuya Village in, Oshana Region - Namibia</p> <p>Coordinates: 18°08'05.7"S 15°27'53.3"E</p>	<p>Project Title: Environmental Impact Assessment (EIA) Study for the Proposed Construction and Operation of a Telecommunication Base Transceiver Station (BTS) Tower at Nakajale Anamulenge Village in, Omusati Region.</p> <p>Location: Nakajale Anamulenge Village in, Omusati Region - Namibia</p> <p>Coordinates: 17°29'41.0"S 15°00'51.0"E</p>	<p>Project Title: Environmental Impact Assessment (EIA) Study for the Proposed Construction and Operation of a Telecommunication Base Transceiver Station (BTS) Tower at Okupundu Village in, Omusati Region.</p> <p>Location: Okupundu Village in, Omusati Region - Namibia</p> <p>Coordinates: 17°34'05.9"S 15°36'25.6"E</p>
<p>Project Title: Environmental Impact Assessment (EIA) Study for the Proposed Construction and Operation of a Telecommunication Base Transceiver Station (BTS) Tower at Tandoro Settlement in, Kavango West Region.</p> <p>Location: Tandoro Settlement in, Kavango West Region - Namibia</p> <p>Coordinates: 17°48'13.6"S 16°47'28.5"E</p>	<p>Project Title: Environmental Impact Assessment (EIA) Study for the Proposed Construction and Operation of a Telecommunication Base Transceiver Station (BTS) Tower at Nlonga Liensa Settlement in Kavango East Region.</p> <p>Location: Nlonga Liensa Settlement in Kavango East Region - Namibia</p> <p>Coordinates: 17°57'06.8"S 20°28'12.6"E</p>	<p>Project Title: Environmental Impact Assessment (EIA) Study for the Proposed Construction and Operation of a Telecommunication Base Transceiver Station (BTS) Tower at Oiyogha Settlement in, Kavango East Region.</p> <p>Location: Oiyogha Settlement in, Kavango East Region - Namibia</p> <p>Coordinates: 18°05'14.6"S 21°28'15.4"E</p>	<p>Project Title: Environmental Impact Assessment (EIA) Study for the Proposed Construction and Operation of a Telecommunication Base Transceiver Station (BTS) Tower at Nakohelewa Village in, Zambezi Region.</p> <p>Location: Nakohelewa Village in, Zambezi Region - Namibia</p> <p>Coordinates: 17°49'23.7"S 24°50'11.0"E</p>
<p>Project Title: Environmental Impact Assessment (EIA) Study for the Proposed Construction and Operation of a Telecommunication Base Transceiver Station (BTS) Tower at Muliwila Village in Zambezi Region.</p> <p>Location: Muliwila Village in Zambezi Region - Namibia</p> <p>Coordinates: 17°55'40.4"S 24°37'42.0"E</p>	<p>Project Title: Environmental Impact Assessment (EIA) Study for the Proposed Construction and Operation of a Telecommunication Base Transceiver Station (BTS) Tower at Walvis Bay Extension 17 in, Erongo Region.</p> <p>Location: Walvis Bay Extension 17 in, Erongo Region - Namibia</p> <p>Coordinates: To be Confirmed</p>		

Contact Details: D&P Engineers and Environmental Consultants
Attention: Mr. I Kasipanzel
PO Box 8401, Windhoek, Namibia
Email: ikaspanzel@dpeng.com.na
Tel: +264 61 902672

Interested & Affected Parties (I&AP) Registration and submission of comments: To comment or receive further information on the project, please register with the consultant (contact details below) as an I&AP before end of business on 25 September 2022. A Background Information Document (BID) has been compiled for the project and is available upon request to the consultant, contact below.

All registered I&APs will be informed throughout the assessment process and will be provided with further opportunities for review and submission of comments. Comments can also be lodged via the online form given:

<https://forms.gle/P9KCoabnQ9u6G6w>

Adopt, Don't Shop!

HELLO!

They call me **RAFIKI**

10 TO 12 WEEKS OLD FEMALE DOG

For happy, wonderful, and fun times!



Rafiki, is a 10 months old female dog. My name means friend, in Kiswahili and best believe I live up to my name, once I've grown fond of my human and have built a bond, I enjoy average physical exercise, and I have a short easy-care coat. I know how to sit, and I walk really well on a leash. I am partially house trained. I would appreciate a home that allows me to sleep indoors for that is what I am accustomed to.

HELLO!

They call me **HUNTER**

3 YEAR OLD MALE CAT

For happy, wonderful, and fun times!



Hunter a 2-year-old male cat looking for his purrfect home. He is an easy-going cat, that enjoys the attention and affection he gets from humans. Hunter will thrive in a home with other cats.



SPCA Windhoek
145 Robert Mugabe Avenue,
Windhoek
Tel: 061-238 654
Emergency Cell: 081-124 4520
(After Hours Only)
Email: info@spcawindhoek.org.na



NOTIFICATION AND CALL FOR PUBLIC PARTICIPATION
ENVIRONMENTAL IMPACT ASSESSMENT (EIA) PROCESS FOR THE PROPOSED DEVELOPMENT OF 22 TELECOMMUNICATION BASE-TRANSCIVER STATION (BTS) TOWERS ON SELECTED SITES COUNTRYWIDE, NAMIBIA

D B P Engineers and Environmental Consultants hereby gives notice to all potentially interested and Affected Parties (I&AP) that an application will be made to the Environmental Commissioner in terms of the Environmental Management Act (No. 7 of 2007) and the Environmental Impact Assessment Regulations (GN 30 of 6 February 2012) for the proposed development of twenty two (22) base transceiver station (BTS) towers.

Powercom (PTY) LTD herein referred to as the proponent has identified different areas that needs improved communication alternatives in Namibia due to growth in population and economic activities. To achieve the objective of improved telecommunication connect with, Powercom has been appointed by Telecom Namibia its sister company to establish telecommunication towers across the identified key locations. In this respect, Powercom has identified sites to construct and operate 22 telecommunication base transceiver station towers across the country.

Powercom (the proponent) has appointed D B P Engineers and Environmental Consultants to conduct the EIA processes for these proposed BTS tower developments. The EIA is being conducted to satisfy the Namibian environmental legislative requirements. The general public as well as any interested and Affected Parties (I&AP) are hereby invited to register their concerns and notify the consultant of any potential environmental and social impacts that may be triggered by the project.

The proposed projects for which the Environmental Clearance Certificates will be applied for are as follows:

<p>1. Project Title: Environmental Impact Assessment (EIA) Study for the Proposed Construction and Operation of a Telecommunication Base Transceiver Station (BTS) Tower at Soehem Settlement, Karas Region - Namibia</p> <p>Location: Soehem Settlement, Karas Region - Namibia</p> <p>Coordinates: 26°49'02.3" S, 17°48'11.9" E</p>	<p>2. Project Title: Environmental Impact Assessment (EIA) Study for the Proposed Construction and Operation of a Telecommunication Base Transceiver Station (BTS) Tower at Lihongo Village in, Oshana Region - Namibia</p> <p>Location: Lihongo Village, Oshana Region - Namibia</p> <p>Coordinates: 18°02'21.8" S 16°10'34.7" E</p>	<p>Project Title: Environmental Impact Assessment (EIA) Study for the Proposed Construction and Operation of a Telecommunication Base Transceiver Station (BTS) Tower at Otshandaba Village in Oshana Region - Namibia</p> <p>Location: Otshandaba Village in Oshana Region - Namibia</p> <p>Coordinates: 17°49'28.0" S 15°38'17.1" E</p>	<p>Project Title: Environmental Impact Assessment (EIA) Study for the Proposed Construction and Operation of a Telecommunication Base Transceiver Station (BTS) Tower at Onkoko Village in, Omusati Region - Namibia</p> <p>Location: Onkoko Village in, Omusati Region - Namibia</p> <p>Coordinates: 17°32'15.3" S 15°07'42.2" E</p>
<p>Project Title: Environmental Impact Assessment (EIA) Study for the Proposed Construction and Operation of a Telecommunication Base Transceiver Station (BTS) Tower at Oshahene Border Post, Omusati Region - Namibia</p> <p>Location: Oshahene Border Post, Omusati Region - Namibia</p> <p>Coordinates: 17°25'05.0" S 14°34'07.6" E</p>	<p>Project Title: Environmental Impact Assessment (EIA) Study for the Proposed Construction and Operation of a Telecommunication Base Transceiver Station (BTS) Tower at Eronga village, Erongo Region - Namibia</p> <p>Location: Springs village, Erongo Region - Namibia</p> <p>Coordinates: 17°28'37.9" S 16°26'34.7" E</p>	<p>Project Title: Environmental Impact Assessment (EIA) Study for the Proposed Construction and Operation of a Telecommunication Base Transceiver Station (BTS) Tower at Mugini Village in, Karungu West Region - Namibia</p> <p>Location: Mugini Village in, Karungu West Region - Namibia</p> <p>Coordinates: 17°52'48.8" S 15°37'52.4" E</p>	<p>Project Title: Environmental Impact Assessment (EIA) Study for the Proposed Construction and Operation of a Telecommunication Base Transceiver Station (BTS) Tower at Kangungu Village in, Karungu East Region - Namibia</p> <p>Location: Kangungu Village in, Karungu East Region - Namibia</p> <p>Coordinates: 17°57'01.7" S 15°39'52.5" E</p>
<p>Project Title: Environmental Impact Assessment (EIA) Study for the Proposed Construction and Operation of a Telecommunication Base Transceiver Station (BTS) Tower at Gomas, Oshana Region - Namibia</p> <p>Location: Gomas, Oshana Region - Namibia</p> <p>Coordinates: 18°14'32.4" S 17°20'55.3" E</p>	<p>Project Title: Environmental Impact Assessment (EIA) Study for the Proposed Construction and Operation of a Telecommunication Base Transceiver Station (BTS) Tower at Isuarua Village in, Zambezi Region - Namibia</p> <p>Location: Isuarua Village, Zambezi Region - Namibia</p> <p>Coordinates: 17°47'28.3" S 14°36'46.9" E</p>	<p>Project Title: Environmental Impact Assessment (EIA) Study for the Proposed Construction and Operation of a Telecommunication Base Transceiver Station (BTS) Tower at Dobsa Brookwater in, Karungu West Region - Namibia</p> <p>Location: Dobsa Brookwater in, Karungu West Region - Namibia</p> <p>Coordinates: 22°52'07.1" S 17°05'37.6" E</p>	<p>Project Title: Environmental Impact Assessment (EIA) Study for the Proposed Construction and Operation of a Telecommunication Base Transceiver Station (BTS) Tower at Nowobes Settlement, Karas Region - Namibia</p> <p>Location: Nowobes Settlement, Karas Region - Namibia</p> <p>Coordinates: 28°49'02.5" S, 17°48'11.9" E</p>
<p>Project Title: Environmental Impact Assessment (EIA) Study for the Proposed Construction and Operation of a Telecommunication Base Transceiver Station (BTS) Tower at Uuyoka village, Oshana Region - Namibia</p> <p>Location: Uuyoka village, Oshana Region - Namibia</p> <p>Coordinates: 17°57'34.7" S 16°36'39.1" E</p>	<p>Project Title: Environmental Impact Assessment (EIA) Study for the Proposed Construction and Operation of a Telecommunication Base Transceiver Station (BTS) Tower at Uuuviva Village in, Oshana Region - Namibia</p> <p>Location: Uuuviva Village in, Oshana Region - Namibia</p> <p>Coordinates: 18°08'05.7" S 15°27'35.3" E</p>	<p>Project Title: Environmental Impact Assessment (EIA) Study for the Proposed Construction and Operation of a Telecommunication Base Transceiver Station (BTS) Tower at Namakaya Anamulenge Village in, Omusati Region - Namibia</p> <p>Location: Namakaya Anamulenge Village in, Omusati Region - Namibia</p> <p>Coordinates: 17°28'41.0" S 15°00'51.0" E</p>	<p>Project Title: Environmental Impact Assessment (EIA) Study for the Proposed Construction and Operation of a Telecommunication Base Transceiver Station (BTS) Tower at Oupandaba Village in, Omusati Region - Namibia</p> <p>Location: Oupandaba Village in, Omusati Region - Namibia</p> <p>Coordinates: 17°34'05.9" S 15°36'35.6" E</p>
<p>Project Title: Environmental Impact Assessment (EIA) Study for the Proposed Construction and Operation of a Telecommunication Base Transceiver Station (BTS) Tower at Tondoro Settlement in, Karungu West Region - Namibia</p> <p>Location: Tondoro Settlement in, Karungu West Region - Namibia</p> <p>Coordinates: 17°46'17.6" S 16°47'28.3" E</p>	<p>Project Title: Environmental Impact Assessment (EIA) Study for the Proposed Construction and Operation of a Telecommunication Base Transceiver Station (BTS) Tower at Nibonga Limes Settlement in Karungu East Region - Namibia</p> <p>Location: Nibonga Limes Settlement in Karungu East Region - Namibia</p> <p>Coordinates: 17°57'08.8" S 16°28'12.6" E</p>	<p>Project Title: Environmental Impact Assessment (EIA) Study for the Proposed Construction and Operation of a Telecommunication Base Transceiver Station (BTS) Tower at Gonga Settlement in, Karungu East Region - Namibia</p> <p>Location: Gonga Settlement in, Karungu East Region - Namibia</p> <p>Coordinates: 18°01'14.8" S 17°28'15.4" E</p>	<p>Project Title: Environmental Impact Assessment (EIA) Study for the Proposed Construction and Operation of a Telecommunication Base Transceiver Station (BTS) Tower at Namakobela Village in, Zambezi Region - Namibia</p> <p>Location: Namakobela Village in, Zambezi Region - Namibia</p> <p>Coordinates: 17°49'23.7" S 14°56'11.0" E</p>
<p>Project Title: Environmental Impact Assessment (EIA) Study for the Proposed Construction and Operation of a Telecommunication Base Transceiver Station (BTS) Tower at Mulkibia Village in Zambezi Region - Namibia</p> <p>Location: Mulkibia Village in Zambezi Region - Namibia</p> <p>Coordinates: 17°55'40.4" S 14°37'42.0" E</p>	<p>Project Title: Environmental Impact Assessment (EIA) Study for the Proposed Construction and Operation of a Telecommunication Base Transceiver Station (BTS) Tower at Waiva Bay Extension 17 in, Erongo Region - Namibia</p> <p>Location: Waiva Bay Extension 17 in, Erongo Region - Namibia</p> <p>Coordinates: To be confirmed</p>		

Contact Details: D B P Engineers and Environmental Consultants
Attention: Mr. T. Kaaligael
PO Box 8401, Windhoek, Namibia
Email: tdkaligael@dbp.com.na
Tel: +264 61 302672

Interested & Affected Parties (I&AP) Registration and submission of comments: To comment or receive further information on the project, please register with the consultant (contact details below) as an I&AP before end of business on 25 September 2022. A Background Information Document (BID) has been compiled for the project and is available upon request to the consultant, contact below.

All registered I&APs will be informed throughout the assessment process and will be provided with further opportunities for review and submission of comments. Comments can also be lodged via the online form given:
<https://forms.gle/7NkCubnQFm8u8dR>



HOME LOAN INVESTMENT CC
Reg. cc: 2009/0449

P.O. BOX 2028, Groutfontein
Tel: 067-240 210
Cell: +264 81 249 1923
Email: home loans@hli.com.na

NB: We are inviting our new clients to register and qualify to be given loans within a period of 48 working hours, we offer the minimum loan amount of N\$5,000.00 to maximum amount N\$250,000.00 to private individuals, both employed and unemployed persons are welcome to register for a loan, in order to register clients should have the following documents:

- Membership registration fee of N\$150.00 (COMPULSARY) advantage:
 - Identity document, source code, passport, driver's license;
 - Latest pay slip, 3 months bank statement;
- NOTE: Approval in 48 working hours period to arrange to pay back the loan between 18 - 48 months.

Please take note: Backlog clients or C/C record are acceptable on reasonable verifiable condition.

Home Loan Investment CC, is pleased to inform our valuable clients that telephonically consultation, application to clients are acceptable and convenient will be provided by Home Loan Investment CC, and available before approval to telephone and professional service.

CONTACT THE DIRECTOR
Mr Nicco at Groutfontein main branch at Orpen/MoM Complex
Office Hours: MON-FRI 08H00 to 18H30
TELE: 067 240 210 / CELL: 081 4912 89623
FAX: 067 243 436 | Email: home loans@hli.com.na

WANT TO ADVERTISE?

Email: sales@observer.com.na
marketing@observer.com.na

CLASSIFIEDS



Rafiki, is a 10 months old female dog. My name means friend, in Kiswahili and best believe I live up to my name, once I've grown fond of my human and have built a bond, I enjoy average physical exercise, and I have a short easy-care coat. I know how to sit, and I walk really well on a leash. I am partially house trained. I would appreciate a home that allows me to sleep indoors for that is what I am accustomed to.



Hunter a 2-year-old male cat looking for his purrfect home. He is an easy-going cat, that enjoys the attention and affection he gets from humans. Hunter will thrive in a home with other cats.



SPCA Windhoek
145 Robert Mugabe Avenue,
Windhoek
Tel: 061-238 654
Emergency Cell: 081-124 4520
(After Hours Only)
Email: info@spcawindhoek.org.na



NOTIFICATION AND CALL FOR PUBLIC PARTICIPATION ENVIRONMENTAL IMPACT ASSESSMENT (EIA) PROCESS FOR THE PROPOSED DEVELOPMENT OF 22 TELECOMMUNICATION BASE-TRANSCIVER STATION (BTS) TOWERS ON SELECTED SITES COUNTRYWIDE, NAMIBIA

D & P Engineers and Environmental Consultants hereby gives notice to all potentially Interested and Affected Parties (I&APs) that an application will be made to the Environmental Commissioner in terms of the Environmental Management Act (No. 7 of 2007) and the Environmental Impact Assessment Regulations (No. 30 of 1 February 2012), for the proposed development of twenty two (22) base transceiver station (BTS) towers.

Powercom (PTY) LTD herein referred to as the proponent has identified different areas that needs improved communication alternatives in Namibia due to growth in population and economic activities. To achieve the objective of improved telecommunication connectivity, Powercom has been appointed by Telecom Namibia its sister company to establish telecommunication towers across the identified different locations. In this respect, Powercom has identified sites to construct and operate 22 telecommunication base transceiver station towers across the country.

Powercom (the proponent) has appointed D&P Engineers and Environmental Consultants to conduct the EIA process for these proposed BTS tower developments. The EIA is being conducted to satisfy the Namibian environmental legislative requirements. The general public as well as any Interested and Affected Parties (I&APs) are hereby invited to register their concerns and notify the consultant of any potential environmental and social impacts that may be triggered by the project.

The proposed projects for which the Environmental Clearance Certificates will be applied for are as follows:

<p>1. Project Title: Environmental Impact Assessment (EIA) Study for the Proposed Construction and Operation of a Telecommunication Base Transceiver Station (BTS) Tower at Sebem Settlement in, Karas Region.</p> <p>Location: Sebem Settlement, Karas Region - Namibia</p> <p>Coordinates: 26°49'02.8"S, 17°48'11.5"E</p>	<p>2. Project Title: Environmental Impact Assessment (EIA) Study for the Proposed Construction and Operation of a Telecommunication Base Transceiver Station (BTS) Tower at Lihongo Village in, Oshana Region.</p> <p>Location: Lihongo Village, Oshana Region - Namibia</p> <p>Coordinates: 18°02'21.8"S 18°30'24.7"E</p>	<p>Project Title: Environmental Impact Assessment (EIA) Study for the Proposed Construction and Operation of a Telecommunication Base Transceiver Station (BTS) Tower at Oshandja Village in Oshana Region.</p> <p>Location: Oshandja Village in Oshana Region - Namibia</p> <p>Coordinates: 17°49'28.0"S 15°38'17.1"E</p>	<p>Project Title: Environmental Impact Assessment (EIA) Study for the Proposed Construction and Operation of a Telecommunication Base Transceiver Station (BTS) Tower at Oshana Village in, Oshana Region.</p> <p>Location: Oshana Village in, Oshana Region - Namibia</p> <p>Coordinates: 17°52'15.3"S 15°37'42.2"E</p>
<p>Project Title: Environmental Impact Assessment (EIA) Study for the Proposed Construction and Operation of a Telecommunication Base Transceiver Station (BTS) Tower at Oshaneene Border Post, Oshana Region.</p> <p>Location: Oshaneene Border Post, Oshana Region - Namibia</p> <p>Coordinates: 17°25'05.0"S, 14°34'07.8"E</p>	<p>Project Title: Environmental Impact Assessment (EIA) Study for the Proposed Construction and Operation of a Telecommunication Base Transceiver Station (BTS) Tower at Epanga Village, Oshana Region.</p> <p>Location: Epanga Village, Oshana Region - Namibia</p> <p>Coordinates: 17°24'42.3"S, 18°20'14.7"E</p>	<p>Project Title: Environmental Impact Assessment (EIA) Study for the Proposed Construction and Operation of a Telecommunication Base Transceiver Station (BTS) Tower at Mujiji Village in, Karungo West Region - Namibia</p> <p>Location: Mujiji Village in, Karungo West Region - Namibia</p> <p>Coordinates: 17°52'48.8"S 18°37'52.4"E</p>	<p>Project Title: Environmental Impact Assessment (EIA) Study for the Proposed Construction and Operation of a Telecommunication Base Transceiver Station (BTS) Tower at Kangongo Village in, Karungo East Region.</p> <p>Location: Kangongo Village in, Karungo East Region - Namibia</p> <p>Coordinates: 17°57'01.7"S 22°09'52.5"E</p>
<p>Project Title: Environmental Impact Assessment (EIA) Study for the Proposed Construction and Operation of a Telecommunication Base Transceiver Station (BTS) Tower at Gurus, Oshana Region - Namibia</p> <p>Location: Gurus, Oshana Region - Namibia</p> <p>Coordinates: 18°14'52.4"S 17°20'55.3"E</p>	<p>Project Title: Environmental Impact Assessment (EIA) Study for the Proposed Construction and Operation of a Telecommunication Base Transceiver Station (BTS) Tower at Kunene Village in, Zambezi Region.</p> <p>Location: Kunene Village, Zambezi Region - Namibia</p> <p>Coordinates: 17°47'28.3"S 24°36'56.5"E</p>	<p>Project Title: Environmental Impact Assessment (EIA) Study for the Proposed Construction and Operation of a Telecommunication Base Transceiver Station (BTS) Tower at Dolra Braaiwer in, Khomas Region - Namibia</p> <p>Location: Dolra Braaiwer in, Khomas Region - Namibia</p> <p>Coordinates: 22°25'02.3"S 17°05'37.6"E</p>	<p>Project Title: Environmental Impact Assessment (EIA) Study for the Proposed Construction and Operation of a Telecommunication Base Transceiver Station (BTS) Tower at Howebes 31 in, Karas Region.</p> <p>Location: Howebes Settlement, Karas Region - Namibia</p> <p>Coordinates: 18°49'02.3"S, 17°48'11.5"E</p>
<p>Project Title: Environmental Impact Assessment (EIA) Study for the Proposed Construction and Operation of a Telecommunication Base Transceiver Station (BTS) Tower at Uuyuka Village, Oshana Region.</p> <p>Location: Uuyuka Village, Oshana Region - Namibia</p> <p>Coordinates: 17°57'24.7"S 18°20'33.1"E</p>	<p>Project Title: Environmental Impact Assessment (EIA) Study for the Proposed Construction and Operation of a Telecommunication Base Transceiver Station (BTS) Tower at Uuuyuka Village in, Oshana Region.</p> <p>Location: Uuuyuka Village in, Oshana Region - Namibia</p> <p>Coordinates: 18°58'05.7"S 17°27'55.3"E</p>	<p>Project Title: Environmental Impact Assessment (EIA) Study for the Proposed Construction and Operation of a Telecommunication Base Transceiver Station (BTS) Tower at Namakwale Amunungwale Village in, Oshana Region.</p> <p>Location: Namakwale Amunungwale Village in, Oshana Region - Namibia</p> <p>Coordinates: 17°29'42.0"S 15°08'51.0"E</p>	<p>Project Title: Environmental Impact Assessment (EIA) Study for the Proposed Construction and Operation of a Telecommunication Base Transceiver Station (BTS) Tower at Oshandja Village in, Oshana Region.</p> <p>Location: Oshandja Village in, Oshana Region - Namibia</p> <p>Coordinates: 17°54'05.8"S 15°38'25.8"E</p>
<p>Project Title: Environmental Impact Assessment (EIA) Study for the Proposed Construction and Operation of a Telecommunication Base Transceiver Station (BTS) Tower at Tandora Settlement in, Karungo West Region - Namibia</p> <p>Location: Tandora Settlement in, Karungo West Region - Namibia</p> <p>Coordinates: 17°46'17.6"S 18°17'23.5"E</p>	<p>Project Title: Environmental Impact Assessment (EIA) Study for the Proposed Construction and Operation of a Telecommunication Base Transceiver Station (BTS) Tower at Ndanga Lintea Settlement in Karungo East Region.</p> <p>Location: Ndanga Lintea Settlement in Karungo East Region - Namibia</p> <p>Coordinates: 17°57'06.8"S 20°28'12.0"E</p>	<p>Project Title: Environmental Impact Assessment (EIA) Study for the Proposed Construction and Operation of a Telecommunication Base Transceiver Station (BTS) Tower at Dvosh Settlement in, Karungo East Region - Namibia</p> <p>Location: Dvosh Settlement in, Karungo East Region - Namibia</p> <p>Coordinates: 18°09'14.8"S 21°28'15.9"E</p>	<p>Project Title: Environmental Impact Assessment (EIA) Study for the Proposed Construction and Operation of a Telecommunication Base Transceiver Station (BTS) Tower at Nalibobius Village in, Zambezi Region.</p> <p>Location: Nalibobius Village in, Zambezi Region - Namibia</p> <p>Coordinates: 17°49'23.7"S 24°50'11.0"E</p>
<p>Project Title: Environmental Impact Assessment (EIA) Study for the Proposed Construction and Operation of a Telecommunication Base Transceiver Station (BTS) Tower at Mutikilla Village in Zambezi Region.</p> <p>Location: Mutikilla Village in Zambezi Region - Namibia</p> <p>Coordinates: 17°55'40.4"S 24°37'42.0"E</p>	<p>Project Title: Environmental Impact Assessment (EIA) Study for the Proposed Construction and Operation of a Telecommunication Base Transceiver Station (BTS) Tower at Walvis Bay Extension 17 in, Erongo Region - Namibia</p> <p>Location: Walvis Bay Extension 17 in, Erongo Region - Namibia</p> <p>Coordinates: To be Confirmed</p>		

Contact Details: D&P Engineers and Environmental Consultants
Attention: Mr. T Kedingeni
PO Box 8402, Windhoek, Namibia
Email: t.kedingeni@dap-engineers.com
Tel: +264 61 302672

Interested & Affected Parties (I&AP) Registration and submission of comments: To comment or receive further information on the project, please register with the consultant (contact details below) as an I&AP before end of business on **25 September 2022**. A Background Information Document (BID) has been compiled for the project and is available upon request to the consultant, contact below.

All registered I&APs will be informed throughout the assessment process and will be provided with further opportunities for review and submission of comments. Comments can also be lodged via the online form given.

<https://forms.gle/9F6C6mDpU6u60>

INFORMATION AND COMMUNICATION TECHNOLOGY FOCUS - 30 SEPTEMBER 2022

TECHNOLOGY ENHANCEMENTS
ARTIFICIAL INTELLIGENCE
BOARDROOM SOLUTIONS
PAYMENT SOLUTIONS
DATA MANAGEMENT
COMMUNICATION
GAMING
MORE...

**BOOK YOUR
ADVERTISING
AND EDITORIAL
SPACE TODAY!**



CONTACT PETER ON 085 750 6616 OR advertise@observer.com.na





SITE INCEPTION REGISTER:

**ENVIRONMENTAL AND SOCIAL MANAGEMENT PLAN: THE PROPOSED TELECOMMUNICATION
BASE TRANSCIVER STATION (BTS) TOWER, GUINAS, OSHIKOTO REGION -NAMIBIA.**

VENUE: GUINAS

TIME: 14:59

DATE: 27 Sept 2009

NAME	Organisation/ Location	PHONE NUMBER	SIGNATURE
G. Oestlund	Guinea Farming Termok	081-222 722	
C. de Jaeger	Guinea Bee	Cell 0818121305	
F. van Zyl	Guinea de	Cell. 0815580514	
P. GROENEWALD	GUINAS VEI	Cell: 081 764 3374	
W.S. Groenewald	Cando Farming - Guinea Vei	081 144 2618	

REGISTRATION AND COMMENTS FORM

ENVIRONMENTAL AND SOCIAL MANAGEMENT PLAN: THE PROPOSED
TELECOMMUNICATION BASE TRANSCIVER STATION (BTS) TOWER AT GUINAS,
OSHIKOTO REGION-NAMIBIA.

KINDLY COMPLETE THIS FORM IN DETAIL AND RETURN TO:

D&P Engineers and environmental consultants
Environmental Consultant: Tendai E. Kasinganeti
Phone: +264813634904
Fax: +264 61 255 207
Email: tkasinganeti@dpe.com.na

PERSONAL DETAILS

Name & Surname... PIETER GROENEWALD
Postal Address.....
Town.....
Email... pegs.fald@gmail.com

What is your main area of interest regarding the proposed developments?

: BETTER CELL PHONE NETWORK ✓
: BETTER CONNECTION FOR RAPIDS ✓
: BETTER FOR ALL OF US ✓

Do you have any points of concern or support regarding the proposed projects?
If "yes", please briefly list these in point format:

YES / NO

I / WE STRONGLY MOTIVATE D&P ENGINEERS
TO CONSTRUCT THIS TOWER ASAP,
BECAUSE WE ALL NEED BETTER NETWORK
PLEASE!

Do you wish this project to proceed?

YES / NO

STAMP/SIGNATURE

pp wester

REGISTRATION AND COMMENTS FORM

ENVIRONMENTAL AND SOCIAL MANAGEMENT PLAN: THE PROPOSED
TELECOMMUNICATION BASE TRANSCIEVER STATION (BTS) TOWER AT GUINAS,
OSHIKOTO REGION-NAMIBIA.

KINDLY COMPLETE THIS FORM IN DETAIL AND RETURN TO:

D&P Engineers and environmental consultants
Environmental Consultant: Tendai E. Kasinganeti
Phone: +264813634904
Fax: +264 61 255 207
Email: tkasinganeti@dpe.com.na

PERSONAL DETAILS

Name & Surname: Francois van Eyk
Postal Address: Email: 0815582516
Town: Tsumeb

What is your main area of interest regarding the proposed developments?

Better for communication between workers to do
work more effective

Better for business on the farms for selling
the product of the farm

Do you have any points of concern or support regarding the proposed projects?
If "yes", please briefly list these in point format:

YES / NO

It will be better for the people and
the production on the farm

We need communication

Do you wish this project to proceed?

YES / NO

STAMP/SIGNATURE

REGISTRATION AND COMMENTS FORM

ENVIRONMENTAL AND SOCIAL MANAGEMENT PLAN: THE PROPOSED
TELECOMMUNICATION BASE TRANSCIEVER STATION (BTS) TOWER AT GUINAS,
OSHIKOTO REGION-NAMIBIA.

KINDLY COMPLETE THIS FORM IN DETAIL AND RETURN TO:

D&P Engineers and environmental consultants
Environmental Consultant: Tendai E. Kasinganeti
Phone: +264813634904
Fax: +264 61 255 207
Email: tkasinganeti@dpe.com.na

PERSONAL DETAILS

Name & Surname... *D. E. Kasinganeti*
Postal Address... *2134 Windhoek* Email...
Town... *Windhoek*

What is your main area of interest regarding the proposed developments?
the wind tower + electricity

Do you have any points of concern or support regarding the proposed projects?
If "yes", please briefly list these in point format:

YES / NO

Do you wish this project to proceed? YES / NO

STAMP/SIGNATURE

REGISTRATION AND COMMENTS FORM

ENVIRONMENTAL AND SOCIAL MANAGEMENT PLAN: THE PROPOSED
TELECOMMUNICATION BASE TRANSCIVER STATION (BTS) TOWER AT GUINAS,
OSHIKOTO REGION-NAMIBIA.

KINDLY COMPLETE THIS FORM IN DETAIL AND RETURN TO:

D&P Engineers and environmental consultants
Environmental Consultant: Tendai E. Kasinganeti
Phone: +264813634904
Fax: +264 61 255 207
Email: tkasinganeti@dpe.com.na

PERSONAL DETAILS

Name & Surname Gunnar Oestland
Postal Address P.O. Box 197 Tsumeb Email gunnar.oestland@wsp.na
Town Tsumeb

What is your main area of interest regarding the proposed developments?

To get better WiFi
Maybe ~~for~~ or tower for Radio club - for fire and alarm.

Do you have any points of concern or support regarding the proposed projects?
If "yes", please briefly list these in point format:

YES / NO

Do you wish this project to proceed?

YES / NO

STAMP/SIGNATURE



REGISTRATION AND COMMENTS FORM

ENVIRONMENTAL AND SOCIAL MANAGEMENT PLAN: THE PROPOSED
TELECOMMUNICATION BASE TRANSCIVER STATION (BTS) TOWER AT GUINAS,
OSHIKOTO REGION-NAMIBIA.

KINDLY COMPLETE THIS FORM IN DETAIL AND RETURN TO:

D&P Engineers and environmental consultants
Environmental Consultant: Tendai E. Kasinganeti
Phone: +264813634904
Fax: +264 61 255 207
Email: tkasinganeti@dpe.com.na

PERSONAL DETAILS

Name & Surname Willem Johannes Groenewald
Postal Address 507 OKAHANDJA Email guinas@condocc.com
Town OKAHANDJA

What is your main area of interest regarding the proposed developments?

Boost Signal
Better Communication
More effective work / Job.

Do you have any points of concern or support regarding the proposed projects?
If "yes", please briefly list these in point format:

YES / NO

This will really help our communication
in this whole area which will help everyone to communicate
faster to respond to field fires and just help us to communicate
better and do our business faster and more efficient.

Do you wish this project to proceed?

YES / NO

STAMP/SIGNATURE

Appendix B:

Maps and Layouts

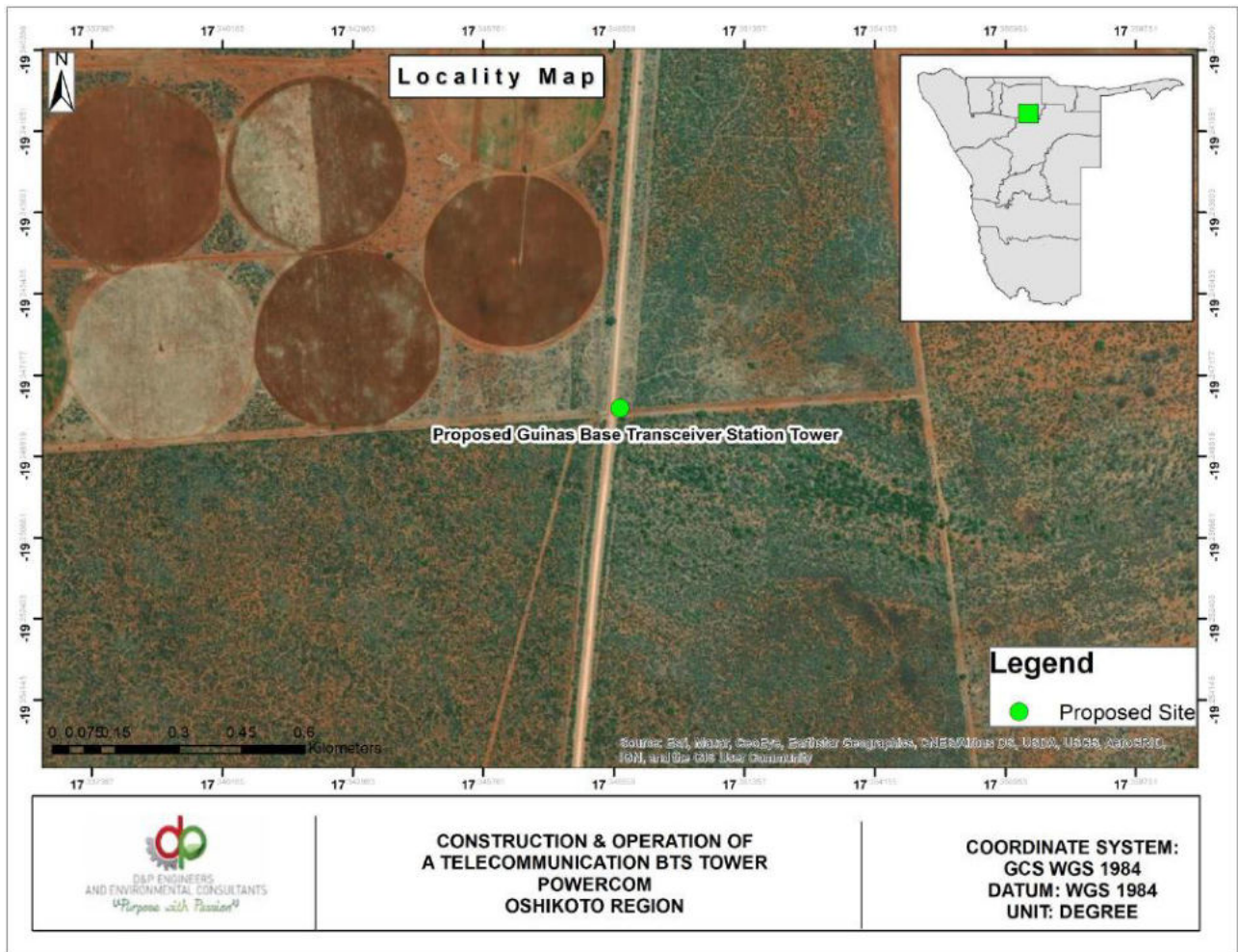

- 1. Locality Map**
- 2. Layout Plan**

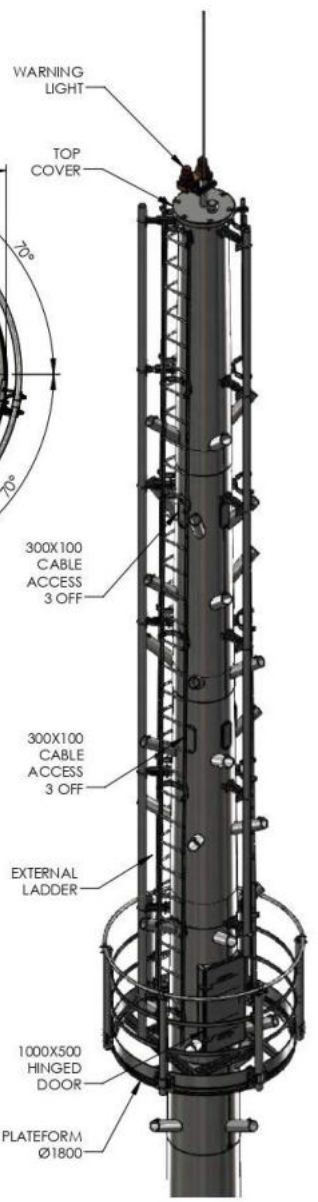
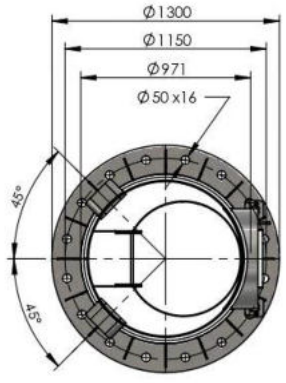
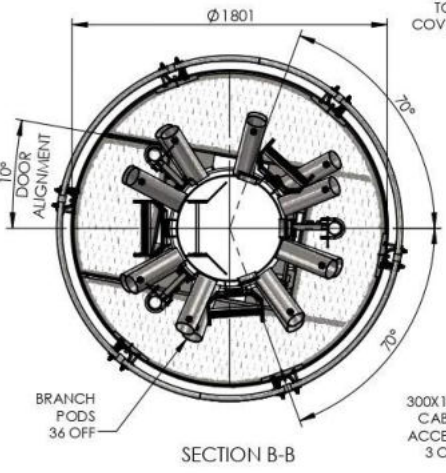
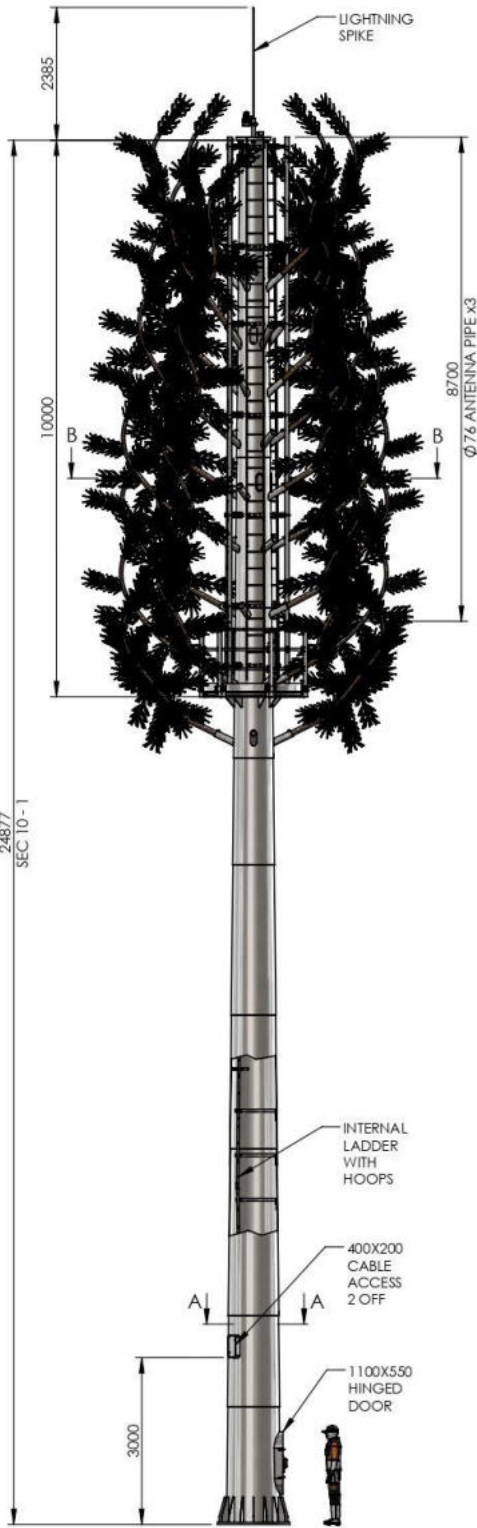

CONSTRUCTION & OPERATION OF
A TELECOMMUNICATION BTS TOWER
POWERCOM
OSHIKOTO REGION

COORDINATE SYSTEM:
GCS WGS 1984
DATUM: WGS 1984
UNIT: DEGREE



0		TLF	2020/09/14
REV	DESCRIPTION	DRAWN	DATE
DESIGN REFERENCE:			
 Sectional Poles <small>SINCE 1960</small>		UNLESS STATED OTHERWISE, DIMENSIONS IN mm DO NOT SCALE	
TITLE: 25m CT PINE WITH 10m PLATFORM & 3X 8m ANTENNA PIPES		DIMENSIONS 0-1m ±0.5mm 1-3m ±1.0mm	
DRW NO: ILG25PI-10PL-TV10B-UNV-R0		ANGLES ±2°	
CLIENT:		SHEET: 1 OF 1	

Appendix C:

Land Tenure, Approvals and Licenses

- 1. Proof of Land Ownership/
Authorisation for
development/ Consent for
Development**



MEMORANDUM OF LEASE AGREEMENT

LUDIE KOLVER

A natural person whose principal place of business situated at Farm Guinas-Vlei,
Republic of Namibia.

(Herein represented by Ludie Kolver in his capacity as the owner and warranting
themselves to be duly authorised thereto)

(Hereinafter referred to as "the Lessor")

And

POWERCOM (PTY) LTD

a Company with registration number 2000/535 established and incorporated in terms of the
relevant company laws of the Republic of Namibia and with its principal place of business
situate at 140 NPTH Building No 4, Julius K Nyerere Street, Southern Industrial Area,
Windhoek, Republic of Namibia

**(Herein represented by Beatus Amadhila in his capacity as the Chief Executive Officer
and warranting himself to be duly authorised thereto)**

(Hereinafter referred to as the "Lessee")



Beatus Amadhila
CEO

PREAMBLE

WHEREAS as the Lessee is desirous of renting the premises from the Lessor for purposes of setting up telecommunications base station;

AND WHEREAS the Lessor is willing to let the premises to the Lessee

NOW THEREFORE the Parties agree as follows:

1. DEFINITIONS AND INTERPRETATION

Definitions

1.1. In this Agreement, unless the context indicates otherwise:-

1.1.1. **"Agreement"** means the entire content of this written document being this lease agreement entered into between the Parties, including addenda; annexures; plans; and/or the likes which have been signed and initialled by the Parties or be incorporated herein by reference, as relevant thereof;

1.1.2. **"Associate"** in regulation to the Lessee means an entity which is for the time being;

1.1.2.1. a subsidiary or holding company of the Lessee within the meaning ascribed to such terms in the Companies Act 61 of 1973; or

1.1.2.2. a subsidiary or holding company of the Lessor.

1.1.3. **"Base Transceiver Station Terminal"** means a mobile telecommunication station with all its ancillary and supporting equipment, building and civil works and personal peripheral equipment hereinafter referred to as BTS.

1.1.4. **"Commencement Date"** means the commencement date of the lease as set out in the annexed Schedule, which is annexed hereto and forms part of this lease agreement;

1.1.5. **"Confidential Information"** of any Party shall mean any information disclosed by that Party to the Receiving Party prior, during and after the conclusion of this Agreement, in terms of this Agreement or otherwise in connection with this agreement;

1.1.6. **"Equipment"** means any property that can easily be moved from one location to another, and/or is collapsible and specifically excludes immovable property or immovable, such as buildings and includes but it is not limited to installations, fences, antennae, containers, structures together with any integral machinery that forms part thereof;

1.1.7. **"Lessor"** means Ludie Kolver as identified in the heading "Parties to this Agreement";

1.1.8. **"Lessee"** means PowerCom (Pty) Ltd as identified in the heading "Parties to this

31/7 2
AKK

Agreement

- 1.1.9. "Lease" means the lease of the premises as in terms of this Agreement;
- 1.1.10. "Parties" means the parties to this Agreement, being the Lessor and Lessee and "Party" means any one of them;
- 1.1.11. "Premises" means the portion of the property selected by the Lessee for the purpose of this agreement, in accordance with the Schedule.
- 1.1.12. "Property" means the Lessor's property upon which the premises are situated as prescribed by the Schedule;
- 1.1.13. "Signature Date" means the date when the last of the Parties hereto have executed and signed this Agreement;

Interpretation

1.2. In this Agreement:

- 1.2.1. Expressions in the singular also denote the plural, and *vice versa*;
- 1.2.2. words and phrases denoting natural persons refer also to juristic persons, and *vice versa*, and
- 1.2.3. pronouns of any gender include the corresponding pronouns of the other genders.

1.3. In this Agreement, unless the context otherwise indicates, a reference to:

- 1.3.1. this Agreement, any other agreement or an instrument or any provision of any of them includes any amendment, variation or replacement of that agreement, instrument or provision;
- 1.3.2. a clause, unless the context otherwise indicates, is a reference to a clause of this Agreement;
- 1.3.3. a statute or statutory provision includes a reference to:-
- 1.3.3.1. any applicable statute or statutory provision as modified or re-enacted (or both) before or after the Signature Date; and
- 1.3.3.2. any subordinate legislation made under any applicable statute or statutory provision before or after the Signature Date;

B. A. N. L.
C. K.

- 1.3.4.a person includes a reference to any natural person, firm, body corporate, unincorporated association or partnership, joint venture, trust and unincorporated association, the state or local government or regulatory department, body, instrumentality, agency, minister or the authority having jurisdiction over any of the Parties;
- 1.3.5.a reference to a person includes a reference to that person's legal personal representatives, executors, administrators, successors and substitutes (including, but not limited to, persons taking by novation) and permitted assigns;
- 1.3.6.In gender includes all genders;
- 1.3.7.time is a reference to Namibian time as per the *Namibian Time Act, 2017*, and the following construction shall apply to time matters:-
- 1.3.7.1. if a period of time is specified and the period dates from a given day or the day of an act or event, it is to be calculated exclusive of that day and if a period of time is specified as commencing on a given day or the day of an act or event, it is to be calculated inclusive of that day;
- 1.3.7.2. if the time for performing an obligation under this Agreement expires on a day that is not a business day, time will be extended until the next business day;
- 1.3.7.3. a reference to a "year" means a period of twelve (12) consecutive months;
- 1.3.7.4. a reference to a "month" is a reference to a calendar month, and more specifically, (i) in reference to a number of months from a specific date, a calendar month commencing on that date or the same date of any subsequent month, and (ii) in any other context, one of the twelve months of the calendar;
- 1.3.7.5. a reference to a "day" is a reference to any day;
- 1.3.7.6. a reference to a "business day" is any day other than a Saturday, Sunday or public holiday in Namibia.
- 1.4. Any provision of this Agreement imposing a restraint, prohibition, or restriction on the Parties shall be so construed that the Parties are not only bound to comply therewith, but are also obliged to procure that the same restraint, prohibition, or restriction is observed by any third party engaged by acting under the authority or with the written consent of the Parties.
- 1.5. Where any term is defined within the context of any particular clause in this Agreement, the term so defined, unless it is clear from the clause in question that the term so defined has limited application to the relevant clause only, shall bear the same meaning as ascribed to it for all purposes in terms of this Agreement, notwithstanding that that term has not been defined in this clause 1.
- 1.6. Any substantive provisions contained in a definition clause shall create substantive

B. A. M. J.
A. N. K.

obligations.

- 1.7. Where a word or phrase is specifically defined, other parts of speech and grammatical forms of that word or phrase have corresponding meanings.

2. LETTING AND HIRING

Subject to the terms and conditions of this Agreement, the Lessee hereby lease the premises from the Lessor.

3. DURATION

Notwithstanding the Signature Date of this Agreement, the agreement shall commence when construction starts and shall endure for a period of 9 years and 11 months, unless terminated earlier in accordance with the provisions of this Agreement.

4. USE OF PREMISES

General

- 4.1. The Premises shall be solely utilised for erection and maintenance of a mobile telecommunication network tower, BTS and for no other purpose whatsoever, unless the Lessor's prior written consent is obtained.

- 4.2. The Lessee shall conduct its Business at the Premises with due regard to the business and interests of the Lessor, and shall not do, nor cause, nor permit anything to be done which is or may become a nuisance to the Lessor, other neighboring tenants or the public.

The Lessee shall be entitled at its own expense, to-

- 4.3. install all or any equipment and/or erect structures on premises, including on the rooftop;
- 4.4. erect, maintain, renew, and replace any equipment required for the purpose referred to in clause 4.1 as well as all required supporting structures upon the premises, and to remove at any time;
- 4.5. affix fittings and fixtures, cables, piping, wiring, conductors and other equipment is kept as well as all required support structures upon the premises, and to remove at the same time;
- 4.6. modify structural elements on the premises after approval by the lessor, introduce innovations, improvements, additions, substitutions of any property equipment and modifications to roof loads (according to generally accepted technical specifications) whatever is necessary to declare the use of the premises;

B. A. 5
ANK

M=

- 4.7. It is further recorded that only persons appointed by the Lessee shall be entitled to supply and install in terms of this clause, the necessary wiring and earthing systems;
- 4.8. Build BTS including necessary foundations and underground works;
- 4.9. The Lessor shall at all times allow the Lessee or its employees, agents or contractors to bring, lay and relay utility power, cables, pipes, telephone and earth wires and other equipment across the property to the premises, and in general shall allow such persons access to the premises 24 hours a day, 7 days a week.
- 4.10. All the afore going installation, and any decommissioning and removal thereof, shall be undertaken at the sole discretion of the Lessee and having given notice to the Lessor or obtaining the Lessor's permission.

Licences and Approvals, Statutes, Regulations and By-Laws

- 4.11. The Lessee shall be required to hold any and all licences and permits that may be required under the laws of Namibia for the conduct of its Business, which licences shall be the duty of the Tenant to obtain.
- 4.12. The Lessee acknowledges and agrees that it shall not be exempted from compliance with any statute, regulation or by-law imposing duties or obligations upon it as Tenant or affecting the use of the Premises or the Property, or the nature of any Improvements that may be erected thereon. The Lessee shall therefore not be entitled to claim relief from any burden or infringement of its rights under this Agreement resulting from the operation of any such statute, regulation or by-law or any action lawfully taken thereunder by any local or other competent authority.

5. RENT AND OTHER CHARGES

- 5.1. The Tenant shall pay to the Lessor a monthly Rental in the sum of N\$ 1500 (One Thousand Five Hundred Namibian Dollars) per month (Exclusive of Value Added Tax) in accordance with the Schedule, in advance on or before the first day of each month.
- 5.2. In addition to paying the rent, the Lessee shall pay the cost of electricity consumed on the site directly to whomsoever shall have levied such charges.
- 5.3. The Lessee shall be entitled at its own cost to upgrade the electricity supplied to the premises to the extent acceptable to the Lessor, which consent shall not be reasonably withheld or delayed.
- 5.4. All costs of other services supplied to the premises, shall likewise be for the account of the Lessee, while the Lessor is liable to pay for rates and taxes and refuse removal charges.

B. A. 6
CHK *MS*

6. SUBLEASE/SITE SHARING

- 6.1. The Lessee shall be entitled to sublease part or whole of the land to the other entities or suppliers of telecommunication services to use the land or equipment thereon on the terms not in conflict with this agreement.
- 6.2. The Lessee shall be entitled, and with the Lessor's prior consent, to share or allow the occupation of the land as well as facilities thereon by a company or entity associated with the Lessee.
- 6.3. The Lessor has the right to apply and join the tower built by the Lessee provided that;
 - 6.3.1. the Lessor applies for the co-location through the regular PowerCom site sharing procedures
 - 6.3.2. the Lessor submits a proper structural analysis produced by a registered structural engineer on the additional load of the added equipment and antennas to the Lessee
 - 6.3.3. the Lessee approve the structural analysis
 - 6.3.4. the principle "First come, First served" applies to this agreement
 - 6.3.5. the requested height or space is not occupied or reserved by another co-locator.

7. INDEMNITY

- 7.1. The Lessee shall be liable for and indemnify the Lessor against any loss or damage that any entity or supplier referred to in clause 6, which is caused to the Lessor's equipment if any and installations on the property in the exercise of its rights by the conferred by the Lessee.
- 7.2. The parties agree that the Lessee, for purpose of using any structure and/or equipment constructed and/or erected, shall require the supply of electric current. The Lessee shall pay for any costs in relations to the installation of supply. It is further recorded that only persons appointed by the Lessee shall be entitled to supply and install, in terms of this clause, the necessary wiring and earthing systems for equipment and/or structure constructed after consenting by the Lessor to the proposed works.

8. CONTRACTING WITH COMPETITORS

The Lessor may contract with any other supplier of telecommunication service provider in respect of its property without the Lessee's prior consent. The Lessor however undertakes that any existing or future supplier or telecommunication service provider, if any, and its equipment shall not limit or obstruct the functionality of the Lessee's equipment or the access to and exit from the premises and the Lessee's site and installations thereon.

B. A. 7
CHK *MS*

9. LESSEE'S RIGHTS OF ENTRY AND CARRYING OUT OF WORKS

The Lessee's representatives, agents, servants and contractors may at all reasonable times, enter the premises and make use of the necessary access roads in order to inspect any part of the Site, to carry out any necessary repairs, replacements or other works, or to perform any other lawful function in the bona fide interests of the Lessee but the Lessee shall ensure that this right is exercised with due regard for and a minimum of interference with, the beneficial enjoyment of the owners of all adjacent properties and those in occupation thereof.

10. OWNERSHIP

Any equipment and/or structures constructed and/or erected in terms of clause 4 shall remain the property of the Lessee, and the parties agree that same shall at all times be regarded as and constitute moveable property, and that the Lessee shall be obliged, at the termination of this Agreement, for whatever reasons, to remove such equipment within a period of 90 (ninety) days after termination of the contract at its own cost.

11. SECURITY

The Lessee and the Lessor shall co-operate with each other and jointly at all times ensure that the entrance to the premises is controlled and shall be locked when the premises are unoccupied.

12. WARRANTIES

- 12.1. The Lessor warrants that he is the registered owner of the property and has exclusive title and rights thereto and that there is no third party rights, real or personal liens, limitations or constraints of any nature whatsoever which may exclude or limit the Lessee's rights under this Agreement.
- 12.2. The Lessor will avoid any act or use of the premises by third parties that may in one or any other way affect the proper functioning of the Lessee's equipment and infrastructure. The Lessee will avoid any act or use of the equipment and infrastructure that will disturb the normal functioning of the existing Lessor's equipment. In case of disturbance or interference caused by either Party, the disturbing Party shall take all necessary measures in order to correct the disturbance and restore the normal functioning of the affected equipment.

13. ALTERATIONS

- 13.1. Upon termination of the agreement, as proprietor of the equipment and/or structures, the Lessee will retain the title to the equipment and/or structures (all the elements and components of the Base Station) and shall, within a reasonable period and its own costs, remove its personal property and fixtures, except for underground supporting structures (if any have been installed) and restore the premises to its original

31/7/8
CHK *ML*

condition, normal wear and tear excepted. The Lessor shall take any necessary action to ensure that the equipment and/or structures be removed by the Lessee or by any person designated by the Lessee.

- 13.2. The Lessor shall not change, move, alter or interfere with any installation construction, erection, structure or equipment in or upon the premises constructed and/or erected by the Lessee, nor shall the Lessor attach any electrical appliances to the electric system of the supplied premises allocated by the Lessor, supplied for the purpose if any such installation, construction, erection, structure or equipment interfere, alter or do any repairs to the electric system referred to above, without the prior written consent of the Lessee first having been obtained, and the Lessor shall not appoint any person other than such persons that may from time to time be approved by the Lessee for the execution of any such works, whether in relation to wiring, the repair of equipment or the joining of cabling or otherwise.

14. BREACH

Should the Lessee default in any payment due under this Agreement or be in breach of its terms in any other way, and fail to remedy such default or breach within 14 days after receiving a written demand that it be remedied, the Lessor shall be entitled, without prejudice to any alternative or additional right of action or remedy available to the Lessor under the circumstances, to cancel this Agreement without further notice with immediate effect.

15. CESSION

The Lessor shall not for whatever reason during the currency of this agreement cede, assign, transfer or make-over any of the Lessee's right in terms of this lease, nor give up occupation or possession of the premises or any portion thereof, without the Lessee's prior consent, which consent shall not be unreasonably withheld. Having obtained the Lessee's consent, the Lessor undertakes to have any obligation under this Agreement transferred and delegated to the transferee's party and shall be jointly responsible for the aforesaid obligation together with Lessee.

16. CONFIDENTIALITY

Notwithstanding the cancellation or termination of this Agreement, no Party ("Receiving Party") shall, at any time after the conclusion of this Agreement, disclose to any Person or use in any manner whatsoever the other Party's ("Disclosing Party") Confidential Information or the existence and contents of this Agreement, provided -

- 16.1 that the Receiving Party may disclose the Disclosing Party's Confidential Information and the existence and contents of this Agreement -

16.1.1 to the extent required by law (other than in terms of a contractual obligation of the Receiving Party);

Handwritten signature and initials:
9
dkt

16.1.2 to permit the use thereof by its Affiliates, employees, representatives and professional advisers (and the employees, representatives and professional advisers of its Affiliates) to the extent strictly necessary for the purpose of implementing or enforcing this Agreement or obtaining professional advice or conducting its business, it being specifically agreed that any disclosure or use by any such Affiliate, employee, representative or professional adviser (or employee, representative or professional adviser of an Affiliate) of such confidential or other information for any other purpose shall constitute a breach of this Clause 13 by the Receiving Party; and

16.2 the provisions of this Clause shall cease to apply to any Confidential Information of any Party that –

16.2.1 is or becomes generally available to the public other than as a result of a breach by the Receiving Party of its obligations in terms of this Clause.

Information received by the Receiving Party from any other Person who did not acquire such Confidential Information subject to any duty of confidentiality in favour of another Person; or was known to the Receiving Party prior to receiving it from the Disclosing Party.

17. FORCE MAJEURE

- 17.1 If either Party is prevented from carrying out any of its obligations in terms of this Agreement as a result of an act of God, strike, fire, riot, war (whether declared or not), power outages, embargoes, international restriction, any court order or any requirements of any other competent authority, or any other circumstances whatsoever which are not within the reasonable control of that Party ("Affected Party"), including any event of force majeure under the Agreement, to the extent applicable, then to the extent that and for so long as the Affected Party is so prevented from performing its obligations in terms of this Agreement, this Agreement will be deemed to have been suspended.
- 17.2 As soon as the Affected Party becomes aware that an act of force majeure is likely to cause a suspension of this Agreement, it shall give notice in writing to the other Party, estimating the approximate duration of such suspension. The estimate shall not be binding, and the Affected Party shall give notice to the other Party as soon as the force majeure ceases to operate.
- 17.3 Should an event of force majeure continue for more than 30 (thirty) days after the date of the notice, then the Affected Party shall be entitled (but not obliged) to terminate this Agreement by giving not less than 14 (fourteen) days written notice to that effect to the other Party.

dkk A 10

M1

18. GOVERNING LAW AND ARBITRATION

- 18.1 This Agreement shall be governed by, construed and interpreted in accordance with the Laws of the Republic of Namibia.
- 18.2 Should any dispute arise between the Parties in connection with the interpretation or application of the provisions of this Agreement or if breach or termination or the validity of any documents furnished by the Parties pursuant to the provisions of this Agreement, that dispute will, unless resolved amongst the Parties be referred to and be determined by arbitration in terms of this clause. Any matter related to arbitration not dealt with under this clause shall be governed by the Arbitration Act, 1965 (Act 42 of 1965).
- 18.3 Any Party to this Agreement may demand that a dispute be determined in terms of this clause by written notice given to the other Party.
- 18.4 This clause will not preclude any Party from obtaining interim relief on an urgent basis from a court of competent jurisdiction pending the decisions of the arbitrator.
- 18.5 The arbitration will be held—
- 18.5.1 In Windhoek,
 - 18.5.2 With only the Parties and the legal and other representatives of the Parties to the dispute being present; and
 - 18.5.3 In accordance with the formalities and procedures settled by the arbitrator and may be held in an informal and summary manner on the basis that it will not be necessary to observe or carry out the usual formalities or procedures, pleadings and discovery or the strict rules of evidence, it being the intention that the arbitration will be held and completed as soon as possible.
 - 18.5.4 The arbitrator will be acceptable to both Parties and if the matter in dispute is principally—
 - 18.5.4.1 A legal matter, a practising Legal Practitioner of at least 10 (ten) years' standing;
 - 18.5.4.2 An accounting matter, a Chartered Accountant of at least 10 (ten) years' standing;
 - 18.5.4.3 Any other matter, an independent person.
- 18.6 Should the Parties to the dispute fail to agree whether the dispute is principally legal, accounting or other matter within 7 (seven) days after the arbitration was demanded, the matter will be deemed a legal matter.
- 18.7 Should the Parties to the dispute fail to agree on the appointment of the arbitrator, the then President of the Council of the Law Society of Namibia or his/her nominee, will be appointed as arbitrator.
- 18.8 The decision of the arbitrator will be final and binding on the Parties to the dispute and may be made an order of any court whose jurisdiction the Parties are subject to at the instance of any of the Parties to the dispute.
- 18.9 The arbitrator will be entitled to make an award, including an award for specific performance, an interdict, damages or a penalty or otherwise as he in his sole discretion

CHK B.A. 11 11/1

may deem fit and appropriate and to deal as he deems fit with the question of costs, including if applicable, costs on an attorney and own client scale, and his own fees.

18.10 The provisions of this clause—

18.10.1 Constitute an irrevocable consent by the Parties to any proceedings in terms hereof and no Party will be entitled to withdraw therefrom or claim at any such proceedings that it is not bound by such provisions;

18.10.2 Are severable from the remainder of this contract and will remain in effect despite termination of or invalidity for any reason of this Agreement.

19 DOMICILIA AND NOTICES

19.1 The parties choose as their *domicilia citandi et executandi* for all purposes of giving any notice, the payment of any sum, the serving of any process and for any other purpose arising from this Agreement (collectively, "notice"), at the following addresses:

19.1.1 The Lessor: Ludie Kolver
Farm Guinas-Vlei
Okahandja
Tel: +264 811247928
E-mail: cando@candocc.com

19.1.2 The Lessee: POWERCOM (PTY) LTD
140 NPTH Building Nr. 4
Julius K Nyerere Street
Southern Industrial Area
Windhoek
Tel: +264 61 209 2090
E-mail: info@powercom.na

19.2 Each of the parties shall be entitled from time to time, by written notice to the other, to vary its domicilium to any other physical address and/or its telephone number and/or its e-mail address as cited.

19.3 Unless the contrary is proved by the addressee, any notice given and any payment made by any Party to the other which is—

19.3.1 Delivered by hand during normal Business Hours of the addressee's *domicilium* for the time being, shall be presumed to have been received by the addressee at the time of delivery; and

19.3.2 No notice sent by normal post shall be regarded as proper notice in terms of this agreement.

BT A 12
CHK

19.4 Notwithstanding anything to the contrary herein contained, any notice actually received by a Party shall be adequate notice to it notwithstanding that it was not sent to or delivered at its chosen *domicilium citandi et executandi*.

20 NON-WAIVER

- 20.1 Neither party shall be regarded as having waived, or be precluded in any way from exercising, any right under or arising from this Agreement by reason of such party having at any time granted any extension of time for, or having shown any indulgence to, the other party with reference to any payment or performance hereunder, or having failed to enforce, or delayed in the enforcement of, any right of action against the other party.
- 20.2 The failure of either party to comply with any non-material provision of this Agreement shall not excuse the other party from performing the latter's obligations hereunder fully and timeously.

21 TERMINATION

- 21.1 Notwithstanding the provisions of any clause above, any Party to this Agreement shall be entitled to terminate this Agreement by giving a 9 (nine) month's written notice to the other Party in the event any of the Parties commits an act of insolvency or is placed under a provisional or final winding-up or judicial management order or if a Party makes an assignment for the benefit of creditors, or fails to satisfy to take steps to have set aside any judgment taken against it within 1 (One) month after such judgment has come to its notice; or
- 21.2 The termination of this Agreement, for whatever reason, will not affect the rights of a Party which may have accrued as at the date of termination and will further not affect any rights which specifically or by their nature survive the termination of this Agreement.

22 WHOLE AGREEMENT AND NON-VARIATION

- 22.1 This is the whole Agreement between the Parties who acknowledge that they have not been induced to enter into this Agreement by any representations or warranties, other than those set out or contained herein. No representations or warranties shall be of any force unless reduced to writing and contained herein.
- 22.2 No alteration, amendment, variation or consensual termination of this Agreement shall be of any force or effect unless reduced to writing and signed by both parties.

BTA
CHK
13
ML

DATED and SIGNED at WINDHOLE..... on this 24..... day of February.....2022 in presence of the undersigned witness:

AS WITNESSES:

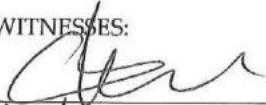
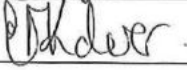





PowerCom (Pty) Ltd
herein duly authorised on behalf of the Lessee
Mr Beatus Amadhila
Chief Executive Officer

SIGNED at on this day of2022
in presence of the undersigned witnesses:

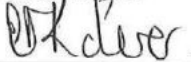

AS WITNESSES:



LUDIE KOLVER
herein duly authorised on behalf of the
Lessor



 14 

SCHEDULE

Site ID : NA
Site Name: Guinas-Vlei
Owner: **Ludie Kolver**

1. Description on the Premises : Greenfield
2. Commencement Date : When construction starts
3. Contract Period : 9 years and 11 months
4. Rental : N\$ 1500.00 per month
5. Escalation : NCPI
6. Method of Payment : **Monthly in advance into Lessor's bank account.**
7. Bank Details :
Name of Account Holder: **Cando Farming**
Name of Bank : **Standard Bank**
Account Number : **041578902**
Branch Code : **Okahandja Branch**



B. A. M. I.
CHK 15

Appendix D:

EIA Team Resumes

- 1. Mr. Tendai E. Kasinganeti**
- 2. Ms. Shiwayu Kristian NN**

Curriculum Vitae (CV) for Tendai. Kasinganeti

1. **Proposed Position:** Environmental Assessment Practitioner
2. **Name of Firm** D&P Engineers and Environmental consultants
3. **Name of Staff** Evidence Tendai Kasinganeti
4. **Date of Birth:** 27 November 1991 **Nationality:** Zimbabwean
5. Education:

Name of University or institution, location, dates attended (year from – year to)	Degree(s)/diploma(s) obtained
Midlands State University, Zimbabwe (11/12011 – 05/2015)	BSc Hons. Geography and Environmental Science Thesis „Spatial and temporal analysis of base transceiver stations development and associated environmental impacts (Zimbabwe)
National University of Science and Technology 2018-2020 (Ongoing)	Master of Geoinformation Science and Earth Observation (Natural Resources Management)

-
6. **Membership of Professional Associations:**
 - Environmental Assessment Professionals of Namibia (EAPAN)
 - International Association for Impact Assessment (IAIA)
-

7. **Other Training:**

Further education:

- Certificate on Going Green for Social Entrepreneurs (Young African Leaders Initiative Network, USA, 2016)
 - Fundamentals of Health and Safety in the Workplace (Allison International, Ireland, 2016)
 - Introduction to Ecosystem Service Valuation and Policy Design (RESMOB Namibia, 2018)
-

8. **Countries of Work Experience:**

- Namibia
- Zimbabwe
- Mozambique

9. **Languages:**

Language	Reading	Speaking	Writing
English	excellent	excellent	Excellent

10. **Employment Record:**

Employment record relevant to the assignment:		
Period	Employing organization and your title/position. Contact info for references	Summary of activities performed relevant to the Assignment

CURRICULUM VITAE Tendai E. Kasinganeti (*Environmental Expert (Backstopper)*)

April 2018 to date	<p>Environmental Practitioner and Consultant</p> <p>Mr. Timo David Director: Project Management D&P Engineers and Environmental Consultants E: tdavid@dpe.com.na</p>	<ul style="list-style-type: none"> ▪ GIS mapping and Environmental Sensitivity mapping. ▪ Providing professional consulting services to clients in Namibia with focus on EIAs, EMPs reporting and compliance advisory. ▪ Conducting Environmental Scoping Assessments and Environmental Management Plans ▪ Application for Environmental Clearance Certificates ▪ Environmental Control for projects during construction and operation. ▪ Environmental Quarterly and Biannual reporting ▪ Environmental monitoring and compliance auditing.
January 2016 to April 2018	<p>Environmental Planner</p> <p>Mr. Henry Krohne Director-Plan Africa Consulting E: pafrica@mweb.com.na</p>	<ul style="list-style-type: none"> ▪ Coordinating and managing Environmental Impact Assessment Studies: ▪ Environmental Reports writing. ▪ Conducting Bio-Physical studies. ▪ Stakeholder engagement and consultation ▪ Environmental Monitoring and Auditing ▪ Land use Mapping and GIS
July 2013 to December 2015	<p>-Student intern -Junior Environmental and Spatial Consultant</p> <p>Mr. Anesu Mudiwa Director: Nwas Environmental Consulting E: anesu@nwas.co.zw W: www.nwas.co.zw</p>	<ul style="list-style-type: none"> ▪ Occupational Health, Safety and Environmental Management ▪ Baseline surveys for EIA projects (Social, ecological, economic and political impact Assessment) ▪ Compiling Environmental and Social Impact Assessment Reports for different projects ▪ Public and Stakeholder consultation ▪ Environmental Compliance Auditing and Quarterly Reports ▪ Soil and water samples processing (Sample collecting, sending for lab tests and interpretation of results) ▪ Emissions testing

<p>11. Detailed Tasks Assigned</p> <ul style="list-style-type: none"> • Stakeholders Engagement • Legislative Frameworks Review • Environmental Compliance Manual and Guidelines Development • Team Leader Backstopper 	<p>12. Work Undertaken that Best Illustrates Capability to Handle the Tasks Assigned</p> <p><i>[Among the assignments in which the staff has been involved, indicate the following information for those assignments that best illustrate staff capability to handle the tasks listed under point 11.]</i></p> <p>Name of assignment or project: Environmental Management Plans development</p> <p>Year: 2017/18</p> <p>Location: Namibia (All Regions) -56 Fuel Retail facilities</p> <p>Client: Engen Namibia/ Nam-Geo Enviro Solutions</p> <p>Main project features:</p> <ul style="list-style-type: none"> • EHS Auditing • Environmental Management Plans Development • Application for Environmental Clearance Certificates for service stations (New application/ Renewals) • Develop EHS monitoring and compliance schedule • Conduct site risk assessment and recommend corrective action plan <hr/> <p>Name of assignment or project: Namibia Water Support Programme</p>
---	---

CURRICULUM VITAE **Tendai E. Kasinganeti** (*Environmental Expert (Backstopper)*)

	<p>Year: 2019</p> <p>Location: Namibia (All Regions)</p> <p>Client: Ministry of Agriculture Water and Forestry/ African Development Bank</p> <p>Main project features:</p> <ul style="list-style-type: none"> • Strategic Environmental and Social Assessment/ Strategic Environmental and Social Management Framework • Environmental Compliance Guidelines for implementing the Namibia Water Sector Support Programme <p>Positions held: Environmental and Social Assessment Expert_</p> <p>Activities performed:</p> <ul style="list-style-type: none"> • Stakeholders Consultation • Regional Workshops • Baseline Environmental Scoping Assessment • Institutional Capability and Needs Assessment for Environmental Compliance • Strategic Environmental and Social Assessment Development (SESA) • Strategic Environmental and Social Management Framework (ESMF) • ESMF Workshop and Compliance Training
	<p>Name of assignment or project: Etunda Feedlot</p> <p>Year: 2019</p> <p>Location: Etunda, Omusati Region-Namibia</p> <p>Client: Ministry of Agriculture Water and Forestry/ European Union</p> <p>Main project features:</p> <ul style="list-style-type: none"> • Environmental and Social Impact Assessment (ESIA)/ Environmental and Social Management Plan (ESMP) <p>Positions held: Environmental and Social Assessment Expert_</p> <p>Activities performed:</p> <ul style="list-style-type: none"> • Environmental Scoping Assessment • National, Regional and International Legal Frameworks Review • Public and Stakeholders Consultation • Groundwater Impact Assessment • Sensitivity Mapping • Environmental and Social Management Plan Development
	<p>Name of assignment or project: Le'Monte Village Development (Township Establishment and Incorporation)</p> <p>Year: 2018</p> <p>Location: Grootfontein, Otjozondjupa Region-Namibia</p> <p>Client: Singleton Commercial Pty Ltd</p>

CURRICULUM VITAE **Tendai E. Kasinganeti** (*Environmental Expert (Backstopper)*)

	<p>Main project features:</p> <ul style="list-style-type: none"> • Environmental and Social Impact Assessment (ESIA)/ Environmental and Social Management Plan (ESMP) <p>Positions held: Environmental and Social Assessment Expert_</p> <p>Activities performed:</p> <ul style="list-style-type: none"> • Environmental Scoping Assessment • National, Regional and International Legal Frameworks Review • Public and Stakeholders Consultation • Groundwater Impact Assessment • Sensitivity Mapping • Environmental and Social Management Plan Development
--	---

ADDITIONAL PROJECTS EXPERIENCES

Client, Year and Country	Project Name and Deliverable
GIZ and Ministry of Agriculture Water and Land Reform, 200-21-Namibia	Flexible Land Tenure System: Environmental and Social Management and Compliance Guideline Manual for the Flexible Land Tenure Implementation
Centre for Natural Resources Governance, 2020-21- Zimbabwe and Zambia	Coal mining and thermal power generation in Sengwa-Kariba areas Zimbabwe: Environmental and Social Impact Assessment-Focus on Environmental Rights and Gender impacts
European Union and Ministry of Agriculture, Water and Forestry, 2020-Namibia	Program to improve livestock efficiency and marketability in the Northern Communal Areas (NCAs) of Namibia: Various Environmental and Social Impact Assessments for specific projects
UNDP Namibia and Ministry of Mines and Energy, 2020-Namibia	Supporting livelihoods through small-scale mining of semi-precious stones, metals and minerals: Environmental, Health, Safety and Social Guidelines for Small Scale Miners in Namibia
AfDB and Ministry of Agriculture, Water and Forestry, 2019-Namibia	Namibia Water Sector Support Programme: Strategic Environmental and Social Assessment and Environmental and Social Management Framework
Keetmanshoop Medical Practice, 2018-Namibia	Keetmanshoop Private Hospital: Environmental and Social Impact Assessment.
Anpro Hides and Skins, 2018-Namibia	Anpro animal rendering plant and tannery: Environmental Impact Assessment

CURRICULUM VITAE **Tendai E. Kasinganeti** (*Environmental Expert (Backstopper)*)

13. Certification:

I, the undersigned, certify that to the best of my knowledge and belief, this CV correctly describes myself, my qualifications, and my experience. I understand that any wilful misstatement described herein may lead to my disqualification or dismissal, if engaged.



[Signature of staff member or authorized representative of the staff] Date: 19-May-21
Day/Month/Year

Full name of authorized representative: Evidence Tendai Kasinganeti

KRISTIAN NDIIPANDA NDEKUPANDA SHIWAYU
ENVIRONMENTAL SCIENTIST
KRISTIAN SHIWAYU | LINKEDIN
LICENSE: LEARNER'S LICENSE

Name of Expert:	Shiwayu Kristian NN
Date of Birth:	03/01/1993
Country of Citizenship/Residence	Namibian Residence

1. Education:

ACADEMIC QUALIFICATIONS		
Name of Course	Institution	Year conferred
International General Certificate in Occupational Health and Safety Practice	NEBOSH	Ongoing
BSc Hons. Integrated Environmental Science	University of Namibia	2019
Master of Science in Integrated Environmental Science and Sustainable Development	The International University of Management	Ongoing

3. Employment Record:

Period	Employing organization and your title/position. Contact info for references	Country	Summary of activities performed relevant to the Assignment
Sept 2022 to date	<p>-Intern: Environmental & Sustainability Consultant</p> <p>Mr. Timo David</p> <p>Director: Project Management</p> <p>D&P Engineers and Environmental Consultants</p> <p>E: tdavid@dpe.com.na</p>	Namibia	<ul style="list-style-type: none"> ▪ Providing professional consulting services to clients in Namibia with focus on EIAs, EMPs reporting and compliance advisory. ▪ Conducting Environmental Scoping Assessments and Environmental Management Plans ▪ Application for Environmental Clearance Certificates

Jan 2021 to May 2022	<p>-Student Employment: Centre for Environmental Studies</p> <p>Mr Sioni Iikela</p> <p>Director: CES, IUM</p> <p>E: s.iikela@ium.edu.na</p> <p>W: 061 433 6412</p>	Namibia	<ul style="list-style-type: none"> ▪ Customer Service ▪ To assist the Centre director, and lecturing staff with all related functions and relevant logistical matters. ▪ Administrative functions ▪ Research
Oct 2020 to Jan 2021	<p>-Graduate Intern: Wildlife and National Parks Division</p> <p>Mr. J Amutenya</p> <p>Chief Warden (Central)</p> <p>Ministry of Environmental, forestry & Tourism (Windhoek)</p> <p>E: jeremia.amutenya@gmail.com</p> <p>W: +26481 0415182</p>	Namibia	<ul style="list-style-type: none"> ▪ Office administrative functions ▪ Law enforcement ▪ Human Wildlife Management ▪ CBNRM (Community Based Natural Resource Management) ▪ Research and Monitoring ▪ Ensure the sustainable utilization of wildlife within central areas of Namibia.
July 2020 to Sept 2020	<p>-Researcher</p> <p>Namibia Research Institution (Gobabeb)</p>	Namibia	<ul style="list-style-type: none"> ▪ Data processing and analyses ▪ Survey techniques ▪ Scientific presentations, while emphasizing teamwork ▪ Critical thinking ▪ Problem-solving skills
Aug 2019 to Sept 2019	<p>-Researcher/Enumerator</p> <p>Namibia agricultural Mechanisation and Seed Improvement Project (NAMSIP)</p>	Namibia	<ul style="list-style-type: none"> ▪ Interviewed farmers in Oshikoto Region ▪ Data collection ▪ Enter data collection in Microsoft Excel for data analyses.
Dec 2017 to Jan 2018	<p>-Field Attachment: Wildlife and National Parks Division</p> <p>Ministry of Environmental, forestry & Tourism (Windhoek)</p>	Namibia	<ul style="list-style-type: none"> ▪ Office administrative functions ▪ Law enforcement ▪ Human Wildlife Management ▪ CBNRM (Community Based Natural Resource Management) ▪ Research and Monitoring ▪ Ensure the sustainable utilization of wildlife within central areas of Namibia.
Dec 2016 to Jan 2017	<p>-Field Attachment: Environmental Officer</p> <p>Tschudi Copper Mine</p>	Namibia	<ul style="list-style-type: none"> ▪ Administration functions ▪ Conducted air quality monitoring ▪ Environmental inspection ▪ Data capturing ▪ Minute taking at the interested and affected parties.

4. **Membership of Professional Associations:**

- Recycle Namibia Forum

5. **Countries of Work Experience:** Namibia (SADC Region)

6. **Languages:**

	<u>Speaking</u>	<u>Reading</u>	<u>Writing</u>
English	Good	Good	Good

7. **Projects Conducted**

Tasks Assigned	Work Undertaken
Biodiversity Report	<p>Name of Assignment or Project: Biodiversity Report for Namibia Uranium (PTY) LTD, EPL 7297.</p> <p>Year: 2021</p> <p>Location: Erongo Region</p> <p>Client: Uranium (PTY) LTD</p> <p>Main project features: Environmental and Biodiversity Impact Assessment</p> <p>Position Held: Biodiversity Specialist</p> <p>Activities performed: Biodiversity Assessment.</p>
D1-Inception Report & Workplan D2-Scoping Report D3-DESIA & ESMP Report D4-ECC Application	<p>Name of Assignment or Project: Biodiversity report for the proposed Erongo substation and associate infrastructure in Karibib Erongo Region, Namibia.</p> <p>Year: 2021</p> <p>Location: Karibib Erongo Region</p> <p>Client: Nampower</p> <p>Main project features: Environmental and Biodiversity Impact Assessment</p> <p>Position Held: Biodiversity Specialist</p> <p>Activities performed: Biodiversity Assessment.</p>

Tasks Assigned	Work Undertaken
D1-Inception Report & Workplan D2-Scoping Report D3-DESIA & ESMP Report D4-ECC Application	<p>Name of Assignment or Project: The Proposed Construction And Operation Of 22 Telecommunication Base Transceiver Station (Bts) Towers Countrywide-Namibia.</p> <p>Year: 2022</p> <p>Location: Country-wide</p> <p>Client: POWERCOM</p> <p>Main project features: Environmental and Social Impact Assessment and Environmental and Social Management Plan.</p> <p>Position Held: Environmentalist</p> <p>Activities performed: Environmental Impact Assessment, Environmental Management plan, Public and Stakeholders Consultation, Reports Drafting and Client liaison</p>

REPUBLIC OF NAMIBIA
NATIONAL IDENTITY CARD

no. 930103 0062 7

SHIWAYU
KRISTIAN NDIIPANDA
NDEKUPANDA



K. Shiwayu



NAMIBIAN POLICE

ONGWEDIVA

11-06-2020

CHARGE OFFICE

Handwritten note in German: "Ich habe die Kopie überprüft in einem Vergleich mit dem Original, welches von mir erstellt wurde. In den Angaben sind keine Abweichungen festgestellt worden." followed by a signature.

DATE OF BIRTH: 1993-01-03
PLACE OF BIRTH: OSHAKATI
SEX: FEMALE
HEIGHT: 1,90
DATE OF ISSUE: 2012-02-28
APR. NO.: V89675

CITIZENSHIP: CITIZEN
EYE COLOUR: BROWN



93010300627