

Environmental Management Plan (EMP)

For the construction and operational phase



PROPOSED ONGOS PORTION 8 & 9 TOWNSHIP DEVELOPMENT PROJECT AND ITS ASSOCIATED WASTE WATER TREATMENT PLANT AND TELECOMMUNICATIONS TOWERS ON FARM ONGOS NO.38 , WINDHOEK

February 2024
UPDATE

Compiled by:



MATRIX CONSULTING SERVICES
P.O. Box 25824 Windhoek
Tel: +264-61 224197

ements (Pty) Ltd only and may not be transmitted to any
mission of Matrix Consulting Services

Compiled for:

FULLBRIGHT INVESTMENT (PTY) LTD
PO Box 20261, Windhoek
Tel:+264 (61) 308106
Fax:+264 (61) 308107

TABLE OF CONTENTS

1.	INTRODUCTION AND BACKGROUND	4
2.	LEGISLATIVE FRAMEWORK	5
3.	ENVIRONMENTAL MANAGEMENT PLAN	9
3.1	RESPONSIBILITIES FOR ENVIRONMENTAL MANAGEMENT.....	9
3.2	TRAINING AND INDUCTION.....	9
3.3	ENVIRONMENTAL INCIDENT REPORTING.....	9
3.4	ENVIRONMENTAL MONITORING.....	10
3.5	EMP ADMINISTRATION	10
3.6	EMP AMENDMENTS	10
3.7	NON COMPLIANCE OF THE EMP.....	10
3.8	ENVIRONMENTAL REGISTER.....	10
3.9	ENVIRONMENTAL CONTROL OFFICER.....	10
3.10	SITE MANAGEMENT.....	11
3.10.1.1	<i>Access routes and work sites.....</i>	<i>11</i>
3.10.1.2	<i>Fire and safety management</i>	<i>12</i>
3.10.1.3	<i>Staff management</i>	<i>12</i>
3.10.1.4	<i>Waste management.....</i>	<i>12</i>
3.10.1.5	<i>Cement and concrete batching</i>	<i>13</i>
3.10.1.6	<i>Hydrocarbons management.....</i>	<i>13</i>
3.10.1.7	<i>Information board.....</i>	<i>13</i>
3.10.1.8	<i>Flood management.....</i>	<i>13</i>
3.10.1.9	<i>Progressive Rehabilitation.....</i>	<i>14</i>
3.10.2	<i>Management of environmental aspects during all phases of the project.....</i>	<i>14</i>
4.	CONCLUSIONS	26

Appendices

Appendix A -----Associated Waste Water Treatment Plant EMP

Appendix B----- Waste Water Treatment Plant Specifications

Appendix C -----Telecommunications Towers EMP

Appendix D -----Lead Consultant CVs

GLOSSARY

ENVIRONMENT	an interconnected system of natural and human-made elements such as land, water and air; all living organisms and matter arising from nature, cultural, historical, artistic, economic and social heritage and values.
ENVIRONMENTAL MANAGEMENT	A management process which seeks to ensure, as far as possible, that no avoidable impact is caused to the environment and that when this is unavoidable that the consequences are understood prior to the impact being caused and that the impact is then mitigated as far as possible.
GROUNDWATER	Water located beneath the earth's surface in soil pore spaces and in the fractures of rock formations
HAZARDOUS WASTE	Waste that poses substantial or potential threats to public health or the environment.
MITIGATION	The implementation of practical measures to reduce adverse impacts or enhance beneficial impacts.
NO-GO AREA	Areas where all construction activities and related matters are prohibited.
POLLUTION	Any change in the environment caused by substances, radioactive or other waves; or noise, odours, dust or heat, emitted from any activity, including the storage or treatment of waste or substances, construction and the provision of services, whether engaged in by any person or an organ of state, where that change has an adverse effect on human health or well-being or on the composition, resilience and productivity of natural or managed ecosystems, or on materials useful to people, or will have such an effect in the future.
REHABILITATION	Restoring the disturbed area to more or less the natural set up.
SITE	An area of ground where the township is developed.

1. INTRODUCTION and BACKGROUND

The aim of an operational EMP is to ensure that the proposed township development is conducted in an environmentally acceptable and safe manner. This Environmental Management Plan (EMP) serves as a managing tool for all construction and operational activities during the development of the Ongos Portion 8 & 9 Township, in Windhoek. The EMP is developed to outline measures to be implemented in order to minimise adverse environmental degradation associated with this development.

The EMP serves as a guiding tool for the contractors and workforce on their roles and responsibilities concerning environmental management on site, and also provides an environmental monitoring framework for all project phases of the development. This environmental management plan aims to take a pro-active route by addressing potential problems before they occur. The EMP acts as a stand-alone document, which can be used during the various phases of the development.

In this report, the Contractor refers to Fullbright Investments (Pty) Ltd and its sub-contractors.

The purpose of the EMP is to:

- ✓ Train employees and contractors with regard to environmental obligations.
- ✓ Promote and encourage good environmental management practices.
- ✓ Outline responsibilities and roles of Fullbright Investments (Pty) Ltd and its contractors in managing the environment.
- ✓ Describe all monitoring procedures required to identify environmental impacts.
- ✓ Minimise disturbance of the natural environment.
- ✓ Develop waste management practices.
- ✓ Prevent all forms of pollution.
- ✓ Protect the natural environment.
- ✓ Prevent soil and water erosion.
- ✓ Comply with all applicable laws, regulations and standards for environmental protection.

Phases covered by the EMP:

Construction Phase

Operational Phase

The construction phase of the township development entails:

- ✓ Land clearance
- ✓ Transporting relevant building material and equipment.
- ✓ Installation of associated electrical supply cables.
- ✓ Installation of associated water pipelines.
- ✓ Installation of associated sewer lines.
- ✓ Installation of storm water management system; and
- ✓ Roads construction

The operational phase will entail:

- ✓ Operation and maintenance of the sewer and water reticulation systems, electrical services and roads.

2. LEGISLATIVE FRAMEWORK

❖ *The Namibian Constitution*

The Namibian Constitution has a section on principles of state policy. These principles cannot be enforced by the courts in the same way as other sections of the Constitution. But they are intended to guide the Government in making laws which can be enforced.

The Constitution clearly indicates that the state shall actively promote and maintain the welfare of the people by adopting policies aimed at management of ecosystems, essential ecological processes and biological diversity of Namibia for the benefit of all Namibians, both present and future.

❖ *Environmental Management Act No.7 of 2007*

This Act provides a list of projects requiring an Environmental assessment. It aims to promote the sustainable management of the environment and the use of natural resources and to provide for a process of assessment and control of activities which may have significant effects on the environment; and to provide for incidental matters.

The Act defines the term “*environment*” as an interconnected system of natural and human-made elements such as land, water and air; all living organisms and matter arising from nature, cultural, historical, artistic, economic and social heritage and values.

The Environmental Management Act has three main purposes:

- (a) to make sure that people consider the impact of activities on the environment carefully and in good time
- (b) to make sure that all interested or affected people have a chance to participate in environmental assessments
- (c) to make sure that the findings of environmental assessments are considered before any decisions are made about activities which might affect the environment

Line Ministry: Ministry of Environment and Tourism

❖ ***Water Resources Management Act of Namibia (2004)***

This act repealed the existing South African Water Act No.54 of 1956 which was used by Namibia. This Act ensures that Namibia's water resources are managed, developed, protected, conserved and used in ways which are consistent with fundamental principles depicted in section 3 of this Act. Part IX regulates the control and protection of groundwater resources. Part XI, titled Water Pollution Control, regulates discharge of effluent by permit.

Line Ministry: Ministry of Agriculture, Water Affairs and Forestry

❖ ***Environmental Assessment Policy of Namibia (1995)***

Environmental Assessments (EA's) seek to ensure that the environmental consequences of development projects and policies are considered, understood and incorporated into the planning process, and that the term ENVIRONMENT (in the context of IEM and EA's) is broadly interpreted to include biophysical, social, economic, cultural, historical and political components.

Line Ministry: Ministry of Environment and Tourism

❖ ***Draft Pollution Control and Waste Management Bill***

The Ongos Portion 8 & 9 township development project, only applies to Parts 2, 7 and 8 of the Bill.

Part 2 stipulates that no person shall discharge or cause to be discharged any pollutant to the air from a process except under and in accordance with the provisions of an air pollution licence issued under section 23. It further provides for procedures to be followed in licence application, fees to be paid and required terms of conditions for air pollution licences.

Part 7 states that any person who sells, stores, transports or uses any hazardous substances or products containing hazardous substances shall notify the competent authority, in accordance with sub-section (2), of the presence and quantity of those substances.

Part 8 calls for emergency preparedness by the person handling hazardous substances, through emergency response plans.

❖ ***Atmospheric Pollution Prevention Ordinance of Namibia No. 11 of 1976***

The Ordinance prohibits anyone from carrying on a scheduled process without a registration certificate in a controlled area. A certificate must be issued if it can be demonstrated that the best practical means are being adopted for preventing or reducing the escape into the atmosphere of noxious or offensive gases produced by the scheduled process. Best practice would be to notify the line Ministry about emissions but it is not a legal requirement.

Line Ministry: Ministry of Health and Social Services

❖ ***Hazardous Substances Ordinance No. 14 of 1974***

The Ordinance applies to the manufacture, sale, use, disposal and dumping of hazardous substances, as well as their import and export and is administered by the Minister of

Health and Social Welfare. Its primary purpose is to prevent hazardous substances from causing injury, ill-health or the death of human beings.

Line Ministry: Ministry of Health and Social Services

❖ **Water Act No.54 of 1956**

This Act provides for Constitutional demands including pollution prevention, ecological and resource conservation and sustainable utilisation. In terms of this Act, all water resources are the property of the state and the EIA process is used as a fundamental management tool.

A water resource includes a watercourse, surface water, estuary or aquifer, and, where relevant, its bed and banks. A watercourse means a river or spring; a natural channel in which water flows regularly or intermittently; a wetland lake or dam, into which or from which water flows; and any collection of water that the Minister may declare to be a watercourse. Permits are required in terms of the Act for the undertaking of the following activities relevant to the proposed project:

- ✓ Discharge of waste or water containing waste into a water resource through a pipe, canal, sewer, sea outfall or other conduit in terms of Section 21 (f); and
- ✓ Disposal of waste in a manner that may detrimentally impact on a water resource in terms of Section 21 (g).

The new waste water treatment plant for the development must comply with the requirements of Section 21(1) and 21(2) of the Water Act (Act 54 of 1956) as amended and that the purified water will comply with the Special Standard as laid out in Government Gazette R553 of 5 April 1962. Additionally, the final effluent will also conform to the envisaged new Water Quality Standards for Effluent, Special Standard, as already defined by the Department of Water Affairs although not yet legalised.

Line Ministry: Ministry of Agriculture, Water Affairs and Forestry

❖ **The Draft Wetland Policy (1993)**

Requires that any wetlands and its associated hydrological functions form a part, to be managed in such a way that their biodiversity, vital ecological functions and life support systems are protected for the benefit of present and future generations.

Line Ministry: Ministry of Environment and Tourism

❖ **Public Health Act 36 of 1919 and Subsequent Amendments**

The Act, with emphasis to Section 119 prohibits the presence of nuisance on any land occupied. The term nuisance for the purpose of this EIA is specifically relevant specified, where relevant in Section 122 as follows:

- ✓ any dwelling or premises which is or are of such construction as to be injurious or dangerous to health or which is or are liable to favour the spread of any infectious disease;
- ✓ any area of land kept or permitted to remain in such a state as to be offensive, or liable to cause any infectious, communicable or preventable disease or injury or danger to health; or

- ✓ any other condition whatever which is offensive, injurious or dangerous to health.

Potential impacts associated with the FULLBRIGHT INVESTMENT (PTY) LTD project are expected to include dust, air quality impacts, noise nuisance and smoke emissions.

Line Ministry: Ministry of Health and Social Services

❖ ***International Conventions and Regulations***

Article 144 of the Namibian Constitution states that “the general rules of public international law and international agreements binding upon Namibia form part of the law of Namibia.” This means that all the international agreements that Namibia signed become part of the law of our country. These laws and/or agreements are:

- ✓ Convention on Biological Diversity, 1992;
- ✓ United Nations Framework Convention on Climate Change, 1992;
- ✓ Kyoto Protocol on the Framework Convention on Climate Change, 1998;
- ✓ Stockholm Convention of Persistent Organic Pollutants, 2001.

❖ ***Municipal By-Laws (City of Windhoek)***

➤ ***Groundwater Protection Regulations***

The protection of the groundwater resource in a development scenario should be provided for, in a formally documented and legislated EIA process. The EIA process or procedure provides for the institutionalization of decision making regarding the potential impact development activities will have on the receiving natural, social and cultural environment. Further, the process makes provision for the identification and listing of types of activities that would be required to follow the process before any authorisation will be given.

➤ ***Environmental Structure Plan and Policy***

The Environmental Structural Plan & Policy provides sufficient information for those making decisions regarding a particular development so that proper environmental evaluation can be conducted, which is appropriate to the scale of the proposed project and the risks to the environment which it may pose.

It establishes where there are potential and real problem environmental areas, such as land degradation, pollution, indiscriminate resource use etc. The Environmental Structural Plan is the baseline upon which the policy is established.

➤ ***Windhoek Town Planning Scheme (2005)***

The Town Planning Scheme enables the comprehensive management of all property and related public sector functions across the city. The guidelines on the Conservation of Natural Resources should be addressed in this project.

➤ ***Policy for the Distribution and Future Usage of Public Open Spaces in Windhoek (2000)***

The policy provides guidelines for the establishment of open spaces and green corridors along drainage lines and sensitive environmental areas. The policy advocates for the provision of land for the explicit development of open spaces.

3. ENVIRONMENTAL MANAGEMENT PLAN

3.1 Responsibilities for environmental management

Fullbright Investments (Pty) Ltd will be responsible for environmental control on site during the construction and operational phase. It is very important a pre-work briefing meeting be held at all times to reach an agreement on specific roles of various parties and penalties for non-compliance.

3.2 Training and induction

Fullbright Investments (Pty) Ltd is bound to be responsible for ensuring that environmental awareness education of all employees and contractors is done satisfactorily. Fullbright Investments (Pty) Ltd should ensure that employees and contractors are made aware of the environmental requirements of the project.

The EMP should form part of the Terms of Reference for all contractors, sub-contractors and suppliers. All contractors, sub-contractors and suppliers will have to sign an agreement to assure that they understood the EMP and that they will comply. All senior staff should familiarise themselves with the full contents of the EMP and its implications. Senior staffs (Foreman/Supervisor) are expected to train and assist the rest of the employees on the contents of the EMP.

3.3 Environmental incident reporting

All environmental incidents occurring at the proposed site will be recorded. The incident report will have to include time, date, location, and nature of the incident, extent of the incident, actions taken, and personnel involved.

All complaints received from the neighbouring community should be directed to the Technical Manager / Environmental Health Officer of Fullbright Investments (Pty) Ltd and channelled to the appointed ECO officer. Fullbright Investments (Pty) Ltd Management should be able to respond to the complainant within a week (even if pending further investigation). It is important that the issues raised are considered and that the complainant feels that their concerns have been addressed to and wherever possible actions taken to address these. All complaints should be entered in the environmental register and all responses and actions taken to address these should be recorded.

3.4 Environmental monitoring

Periodic environmental monitoring must be taken on a regular basis. Monitoring should be done in order to ensure compliance with all aspects of the EMP. Surface and groundwater Pollution Monitoring must be done throughout the operational phase so as to pro-actively detect pollution or leakage from the waste water treatment plant. Findings should be liaised with to all responsible officers as chain command.

3.5 EMP administration

Copies of this EMP shall be kept at the site office and should be distributed to all senior staff members, including those of the contractors.

3.6 EMP amendments

The EMP amendments can only be made with the approval of the ECO officer and ultimately the DEA. Amendments to the EMP should be liaised to all employees and contractors.

3.7 Non compliance of the EMP

Problems may occur in carrying out mitigation measures or monitoring procedures that could result in non-compliance of the EMP. The responsible personnel should encourage staff to comply with the EMP, and address acts of non-compliance and penalties.

Fullbright Investments (Pty) Ltd is responsible for reporting non-conformance with the EMP, to the ECO officer. The management of Fullbright Investments (Pty) Ltd, in consultation with the ECO officer must, thereafter, undertake the following activities:

- ✓ Investigate and identify the cause of non-conformance.
- ✓ Report matters of non-conformance to City of Windhoek Environmental Department (depending on the severity of the incident).
- ✓ Implement suitable corrective action as well as prevent recurrence of the incident.
- ✓ Assign responsibility for corrective and preventative action.
- ✓ Any corrective action taken to eliminate the causes of non-conformance shall be appropriate to the magnitude of the problems and commensurate with the environmental impact encountered.

3.8 Environmental Register

An environmental register should be kept on site in which incidents related to actual impacts are recorded. This will include information related to incidents as spillages, dust generation and complaints from adjacent neighbours. It should also contain information relating to actions taken. Any party on site may complete the register, however, it is envisaged that the Technical Manager, the contractor and the ECO officer will be the main contributors, and who will also be the main parties involved in suggesting mitigation measures.

3.9 Environmental Control Officer

The Environmental Control Officer for the site is an independent environmental officer appointed by Fullbright Investments (Pty) Ltd to monitor and review the on-site environmental management and implementation of this EMP.

Duties of the ECO officer:

- ✓ The identification of potential environmental impacts, prior to the onset of decommissioning. A site visit may also be required prior to site development. This would be carried out in consultation with the Technical Manager.
- ✓ Providing of an environmental register at the site to be filled in by any person reporting an environmental incident, issue or concern and inspected by the ECO officer on a regular basis to check for issues raised and actions taken.
- ✓ Ensuring that the EMP conditions are adhered to at all times and taking action.
- ✓ Ensuring that environmental impacts are kept to a minimum.
- ✓ Reviewing and approving method statements in consultation with the Technical Manager.
- ✓ Reporting to Fullbright Investments (Pty) Ltd and the Technical Manager on a regular basis and advising of any major environmental impacts. Attending the site meetings (when necessary)
- ✓ Inspecting the site and surrounding areas regularly, and monitoring an ongoing environmental awareness program in conjunction with the Technical Manager.
- ✓ Requesting the removal of people and/or equipment not complying with the specifications of EMP.
- ✓ Keeping both a written and photographic record of progress on site from an environmental perspective, and an ad hoc record of all environmental incidents
- ✓ Undertaking continual review of the EMP and submitting a report to the relevant stakeholders.
- ✓ The ECO officer will submit all written instructions and verbal requests to NHE and Fullbright Investments (Pty) Ltd via the Technical Manager and Project Engineer.

3.10 Site Management

Areas outside this designated working zone shall be considered “no go” areas. The offloading zones must be clearly demarcated when offloading goods to enhance safety around the project location.

3.10.1.1 Access routes and work sites

During the construction phase, road transport trucks will access the project location via Monte Christo Road. No new tracks/roads shall be established and only existing roads may be used. Work sites shall be clearly demarcated and road signs erected where needed. The general public should not have unauthorised/uncontrolled access to the project location during this phase.

Vehicle access will be limited to one or two entrances to facilitate control. Access must be of a high standard to prevent unauthorised access from entering the site.

The entrance will be manned during the operation hours; and access routes will be closed to prevent unauthorised entry. A notice board, in two languages, must be erected at the entrance and must state entrance requirements and operating

hours of the site, the operator/responsible person and emergency telephone numbers. Suitable signs must also be erected on the approach roads and on-site, to direct drivers and to control speed.

Road access to the working face of the township development must be maintained at all times in a manner suitable to accommodate vehicles normally expected to use the facility. Roads must be regularly graded and wetted to control dust, where necessary.

Furthermore, on-going controls, such as fencing and policing, must be implemented.

3.10.1.2 Fire and safety management

All electrical installations, wiring and systems at the project location, must be approved by a qualified electrician who will issue a Certificate of Compliance.

Proper handling, storage, use and disposal of any hazardous waste (e.g. hydrocarbons, paint, batteries, radioactive waste e.t.c) should be conducted. Hydrocarbons are volatile under certain conditions and their vapours in specific concentrations are flammable. If precautions are not taken to prevent their ignition, fire and subsequent safety risks may arise.

No uncontrolled fire, whether for cooking or any other purpose, is to be made at the project location during both the construction and operation phases. The Contractor shall take all reasonable measures and active steps to avoid increasing the risk of fire through activities on site and prevent the accidental occurrence or spread of fire; and shall ensure that there is sufficient fire-fighting equipment on site at all times. This equipment shall include fire extinguishers. The Contractor should be prepared for such events.

3.10.1.3 Staff management

The Contractor must ensure that their employees have suitable personal protective equipment and properly trained in fire fighting and first aid. Training records must be kept for future references.

3.10.1.4 Waste management

Waste will be generated in the form of rubble, cement bags, pipe and electrical wire cuttings. Contaminated soil due to oil leakages, lubricants and grease from the construction equipment and machinery may also be generated during the construction phase.

The oil leakages, lubricants and grease must be addressed. Contaminated soil must be removed and disposed off at the hazardous waste cell at Kupferberg Landfill. The contractor must provide containers on-site, to store any hazardous waste produced. Regular inspection and housekeeping procedure monitoring should be maintained by the contractor.

Waste in the form of solid waste from households, businesses and institutions will also be generated during the operational phase. Waste will be removed and

disposed off at Kupferberg Landfill by City of Windhoek Waste Removal Contractors e.g. Rent-a-Drum, Kleen Tek etc.

The City of Windhoek will have waste skips around Ongos Portion 8 & 9 townships like the rest of the suburbs in Windhoek.

The new waste water treatment plant for the development must comply with the requirements of Section 21(1) and 21(2) of the Water Act (Act 54 of 1956) as amended and that the purified water will comply with the Special Standard as laid out in Government Gazette R553 of 5 April 1962. Additionally, the final effluent will also conform to the envisaged new Water Quality Standards for Effluent, Special Standard, as already defined by the Department of Water Affairs although not yet legalised. Effluent discharge monitoring must be done periodically to ensure compliance, and results must be shared with City of Windhoek and MAWF.

3.10.1.5 Cement and concrete batching

Concrete mixing directly on the ground shall not be allowed and shall take place on an impermeable surface. All run-off from batching areas shall be strictly controlled, and cement contaminated water shall be collected, stored and disposed of at a suitable waste disposal facility.

3.10.1.6 Hydrocarbons management

If any spillage occurs, contaminated soil shall be collected in a holding tray or drum and which will then disposed at a **hazardous waste disposal site**. Any spillage of more than 200 litres must be reported to the Ministry of Mines and Energy as per the Petroleum Products Act.

The Contractor shall take all reasonable measures to prevent surface or groundwater pollution from the release of oils and fuels.

3.10.1.7 Information board

The Contractor will be responsible for erecting information boards on site. The number and locations of these boards shall be agreed upon by the ECO officer.

The contents of the information board shall be provided by the Technical Manager and will essentially be to advise the public of the construction activity and the prohibition on entering certain areas. The information board shall also provide the contact number of the ECO, to ensure that the public can access relevant information and lodge any complaints during the construction phase of the township development.

3.10.1.8 Flood management

The township development will be designed in such a way that surface water run-off is well developed. Storm water management of the township development should be a key aspect of flood management at the township. All culverts should be kept clean to allow storm water to flow freely.

3.10.1.9 Progressive Rehabilitation

Rehabilitation must commence as soon as possible on areas where construction has taken place or no further development is to take place, i.e. on completed excavations, soil/rock cutting hips, slopes etc.

3.10.2 Management of environmental aspects during all phases of the project

Groundwater

Construction phase	
Description	<p>Possible Groundwater quality could be impacted through leachate of oil leakages, diesel, lubricants and grease from the heavy-duty equipment and machinery utilised during construction phase. Care must be taken to avoid contamination of soil and groundwater. Drip trays must be used when removing oil from machinery.</p> <p>Run-off from overflowing onsite temporary sewage systems might have an impact on geological structures present. Inflow into these structures would cause a pollution thread. The presence of a north-south striking faults on the eastern half of the project location should be noted and protected at all cost.</p> <p>There is a slight potential impact on groundwater users in the area. Potential impact on the natural environment from the polluted groundwater also exists. In general, impact on groundwater due to the construction of the township development is considered to be minimal through proper management practices.</p>
Proposed Mitigation Measures	Prevent spillages of any chemical or fuel. Use drip trays when doing maintenance on machinery. Maintenance should be done on dedicated areas with linings or concrete floor. No maintenance of machinery may be done at the project location. Implementation of sound and proper management practices.
Proposed Monitoring	Regular visual inspection.
Responsible Party	FULLBRIGHT INVESTMENTS (PTY) LTD / Contractors

Operational phase	
Description	<p>Spillages and/or leakages of various possible contaminants might occur due to failure of reticulation pipelines, storage tanks or the waste water treatment plant. Contaminated soil might pose a risk to surface water.</p> <p>Potential impact on the natural environment from possible polluted groundwater also exists. The area is subjected to north-south structures, which might act as preferential pathways for any contaminants entering the saturated zone.</p>
Proposed Mitigation Measures	<p>The risk can be lowered further through the use of suitable and adequate SANS approved piping material; and installation should be done by certified installers/technicians. All surface spillages and leakages must be cleaned up immediately. Proper containment structures should be constructed to avoid any possible leakages. Proper containment should be used in cases of sewerage system and treatment plant maintenance to avoid any possible leakages. A buffer pond must form part of the waste water treatment plant to hold out of specifications water during the breakdown events of the waste water treatment plant.</p> <p>Pollution Monitoring boreholes must be installed to proactively monitor pollution around the proposed waste water treatment plant. Monitoring boreholes must be installed both downstream and upstream on WWTP in the Aretaragas River. This will enable early detection of pollution emanating from the treatment plant.</p> <p>The presence of an emergency response plan and suitable equipment is advised, so as to react to any spillage or leakages properly and efficiently.</p>
Proposed Monitoring	Groundwater monitoring sampling for pollution.
Responsible Party	FULLBRIGHT INVESTMENTS (PTY) LTD/COW

Surface Water

Construction phase	
Description	<p>Contamination of surface water might occur through oil leakages, diesel, lubricants and grease from the heavy-duty equipment and machinery during the construction phase.</p> <p>Surface runoff emanating from overflowing and/or leakages from temporary chemical and sewage storage and reticulation pipeline systems might reach surface water bodies like the Aretaragas River. Potential Health problems caused by viruses, bacteria and parasites found in the effluent would be the main concern from this pathway.</p> <p>Potential health impact on surface water users and on the natural environment associated with the nearby streams and rivers. Surface runoff from the site is expected in a northerly direction.</p>
Proposed Mitigation Measures	<p>Machinery should not be serviced on site to avoid spills. All spills should be cleaned up as soon as possible. Hydrocarbon/chemical contaminated soil; clothing or equipments should not be washed within 25m of any surface water.</p>
Proposed Monitoring	<p>Regular visual inspection. Surface water quality monitoring in cases of evident pollution.</p>
Responsible Party	<p>FULLBRIGHT INVESTMENTS (PTY) LTD / Contractors</p>

Operational phase	
Description	<p>Spillages and/or leakages of various possible contaminants might occur due to failure of reticulation pipelines, storage tanks or the waste water treatment plant. Contaminated soil might pose a risk to surface water. All spills should be cleaned up as soon as possible. An emergency plan should be in place on how to deal with spillages and leakages during this phase.</p> <p>Potential health impact on surface water users and on the natural environment associated with the river channels in the area do exist. This may result in socio-economic impacts on surface water users.</p>
Proposed Mitigation Measures	<p>Drip trays and/or plastic sheeting should be used to contain any leaks emanating from the heavy-duty machinery and fleet.</p> <p>All spills should be cleaned up as soon as possible. The presence of an emergency response plan and suitable equipment is advised, so as to react to any spillage or leakages properly and efficiently.</p> <p>Proper containment should be used in cases of sewerage system and treatment plant maintenance to avoid any possible leakages. A buffer pond must form part of the waste water treatment plant to hold out of specifications water during the breakdown of the waste water treatment plant.</p>
Proposed Monitoring	<p>Pollution Monitoring boreholes must be installed to pro-actively monitor pollution around the proposed waste water treatment plant. Monitoring boreholes must be installed both downstream and upstream on WWTP in the Aretaragas River. This will enable early detection of pollution emanating from the treatment plant.</p>
Responsible Party	FULLBRIGHT INVESTMENTS (PTY) LTD/COW

Air Quality (Dust Pollution)

Construction phase	
Description	Dust will be generated during the construction and installation of bulk services, and problems thereof are expected to be site specific. Dust is expected to be worse during the winter months when strong winds occur. Release of various particulates from the site during the construction phase and exhaust fumes from vehicles and machinery related to the construction of bulk services are also expected to take place. Dust is regarded as a nuisance as it reduces visibility, affects the human health and retards plant growth.
Proposed Mitigation Measures	It is recommended that regular dust suppression be included in the construction activities, when dust becomes an issue. No unnecessary revving of engines or operation of vehicles is allowed. In general, the servicing of Ongos Portion 8 & 9 Township is envisaged to have minimal impacts on the surrounding air quality.
Proposed Monitoring	Regular visual inspection.
Responsible Party	FULLBRIGHT INVESTMENTS (PTY) LTD / Contractors

Operational phase	
Description	Vehicles that will be accessing Ongos Portion 8 &9 and Monte Christo Farm will contribute to the release of hydrocarbon vapours, carbon monoxide and sulphur oxides into the air. Possible release of sewer odour might occur, due to sewer system or treatment plant failure or during maintenance. All maintenance procedures of bulk services of Ongos Portion 8 &9 Township have to be designed to enable environmental protection.
Proposed Mitigation Measures	The waste water treatment processes must be enclosed and the gasses must be extracted and then be cleaned (scrubbed) by passing the gas through the Trickling Filter. An exclusive zone of 150 m will be allowed around the Ongos WWTP, where no houses will be built. This zone will be more than sufficient to ensure no obnoxious odours will be generated and/or vectors will be attracted that may become a nuisance to households adjacent to the plant.
Proposed Monitoring	Quarterly inspection, and addressing air quality complaints. A register for deteriorated air quality complaints from the Ongos WWTP must be kept.
Responsible Body	FULLBRIGHT INVESTMENTS (PTY) LTD/COW

Health and Safety

Construction phase	
Description	<p>Safety issues could arise from the earthmoving equipment and tools that will be used on site during the construction phase. This increases the possibility of injuries and the contractor must ensure that all staff members are made aware of the potential risks of injuries on site. The presence of equipment lying around on site may also encourage criminal activities (theft).</p> <p>No open flames, smoking or any potential sources of ignition should be allowed at the project location. Signs such as 'NO SMOKING' must be prominently displayed in parts where inflammable materials are stored on the premises.</p>
Proposed Mitigation Measures	<p>Equipment and machinery operators should be equipped with ear protection equipment. Operations should be strictly between 07H00 to 19H00. First aid and safety awareness training for contractors.</p> <p>Ensure the general safety and security at all times by providing day and night security guards and adequate lighting within and around the premises. The staff must be properly trained on safety and health issues of the project. Workers should be fully equipped with personal protective equipment gear.</p>
Proposed Monitoring	Safety procedures evaluation. Health and safety incident monitoring.
Responsible Party	FULLBRIGHT INVESTMENTS (PTY) LTD /Contractors

Operational phase	
Description	<p>The number of health and safety threats exist during operational activities of Ongos Portion 8 & 9 Township. Individuals in the community can suffer from noise from maintenance activities around Ongos Portion 8 & 9 Township. Accidents on roads as a result of increased traffic and deterioration.</p> <p>The contractors are advised to ensure that proper personal protective gear and first aid kits are available, at all times. Workers should also be properly trained in first aid and safety awareness.</p>
Proposed Mitigation Measures	Operators and maintenance contactors must be properly trained on safety and health issues. Workers should be fully equipped with personal protective equipment gear.
Proposed Monitoring	Regular inspection and incident monitoring report evaluation.
Responsible Body	FULLBRIGHT INVESTMENTS (PTY) LTD/COW

Noise Impact

Construction phase	
Description	<p>An increase of ambient noise levels at Ongos Portion 8 & 9 Township site is expected due to the construction activities. Noise pollution due to heavy-duty equipment and machinery will be generated.</p> <p>It is not expected that the noise generated during construction will impact any third parties.</p>
Proposed Mitigation Measures	<p>Sensitive construction vehicle drivers and machinery operators to switch off engines of vehicles or machinery not being used. Ensure engines of machinery are fitted with mufflers. Equipment and machinery operators should be equipped with ear protection equipment. Operations should be strictly between 07H00 to 19H00.</p>
Proposed Monitoring	<p>Strict operational times. Regular inspection.</p>
Responsible Party	<p>FULLBRIGHT INVESTMENTS (PTY) LTD /Contractors</p>

Operational phase	
Description	<p>Noise pollution already exists around the site in the form of noise generated from vehicles frequenting the existing Monte Christo road. Noise pollution due to this projecting the operational phase is expected to be mainly from generators or pumps, road maintenance machinery during maintenance.</p>
Proposed Mitigation Measures	<p>Ensure that generator engines are fitted with mufflers. Operators working in close proximity to the generators should be equipped with ear protection equipment, when noise becomes an issue. Observation of on-site noise levels by the Manager or Supervisor of Bulk Services Maintenance Department.</p>
Proposed Monitoring	<p>Observation of on-site noise levels.</p>
Responsible Body	<p>FULLBRIGHT INVESTMENTS (PTY) LTD/COW</p>

Waste Generation

Construction phase	
Description	This can be in a form of rubble, cement bags, pipe and electrical wire cuttings. Contaminated soil due to oil leakages, lubricants and grease from the construction equipment and machinery may also be generated during the construction phase.
Proposed Mitigation Measures	The oil leakages, lubricants and grease must be addressed. Contaminated soil must be removed and disposed off at the hazardous waste cell at Kupferberg Landfill. The contractor must provide containers on-site, to store any hazardous waste produced. Ensure that no excavated soil, refuse or building rubble generated on site are not placed, dumped or deposited on adjacent/surrounding properties or land.
Proposed Monitoring	Regular inspection and housekeeping procedure monitoring. Observation of site appearance by the manager.
Responsible Party	FULLBRIGHT INVESTMENTS (PTY) LTD /Contractors

Operational phase	
Description	Waste in the form of contaminated soil, rubble and domestic waste. Littering along access roads may also be produced during the operational phase.
Proposed Mitigation Measures	Waste must be removed and disposed off at Kupferberg Landfill by City of Windhoek Waste Removal Contractors e.g. Rent-a-Drum, Kleen Tek etc.
Proposed Monitoring	Regular visual inspection.
Responsible Body	FULLBRIGHT INVESTMENTS (PTY) LTD/COW

Traffic

Construction phase	
Description	<p>The Ongos Portion 8 & 9 Township activities are expected to have a minor impact on the movement of traffic along Monte Christo Road, could have an impact on traffic around the area. No diversion of traffic or closure of roads is expected.</p> <p>Speed limit warning signs must be erected to minimise accidents. Heavy-duty vehicles and machinery must be tagged with reflective signs or tapes to maximise visibility and avoid accidents.</p>
Proposed Mitigation Measures	<p>It is recommended that if the need arises for traffic diversion or road closure, FULLBRIGHT INVESTMENTS (PTY) LTD should liaise with the City of Windhoek. Speed limit and site warning signs must be erected to minimise accidents. Construction vehicles must be tagged with reflective signs or tapes to maximise visibility of the vehicles and avoid accidents.</p>
Proposed Monitoring	<p>Observations of the traffic flow on Monte Christo Road.</p>
Responsible Party	<p>FULLBRIGHT INVESTMENTS (PTY) LTD /Contractors</p>

Operational phase	
Description	<p>Traffic around Ongos portion 8 & 9 Township should be monitored, to avoid traffic congestion in the area. Speed limits and road signs as set out by City of Windhoek Traffic Department should be adhered to in order to minimise accidents.</p>
Proposed Mitigation Measures	<p>It is advisable that traffic lights be erected at the entrance along the Monte Christo road to ease traffic flow around the new township.</p>
Proposed Monitoring	<p>Observations of the traffic flow on Monte Christo Road.</p>
Responsible Body	<p>FULLBRIGHT INVESTMENTS (PTY) LTD/COW</p>

Ecological impacts

Construction phase	
Description	The vegetation at Farm Ongos and Farm Monte Christo is typically a highland savannah with a dominance of phanerophyte species such as <i>A. mellifera</i> and <i>D. cinerea</i> , <i>A.reficiens</i> , <i>A. erubescens</i> , <i>G. Flava</i> and <i>C.alexandrii</i> that are known to occur commonly in this area. No red-listed species were encountered during the survey. Tree species encountered here that are currently protected under the Forestry Act (Act 12 of 2001) in Namibia include: <i>Boscia albitrunca</i> , <i>Albizia anthelmintica</i> , <i>Acacia erioloba</i> , <i>Faidherbia albida</i> , and <i>Ziziphus mucronata</i> .
Proposed Mitigation Measures	Disturbance of areas outside the designated working zone is not allowed. Caution must be exercised to minimise damage to protected trees. It is strongly recommended that these trees should rather be factored into the development as far as possible, because they can be used for shade and can contribute positively to the general aesthetics of the proposed development. In addition, indigenous tree species are incredibly hardy and well adapted to Namibia’s harsh and often unpredictable climatic conditions; and require significantly low amounts of water to grow & survive. Riparian Vegetation should be conserved as much as possible
Proposed Monitoring	Regular site inspection by the Site Manager or Supervisor.
Responsible Party	FULLBRIGHT INVESTMENTS (PTY) LTD /Contractors

Operational phase	
Description	No major impacts are expected as the proposed Ongos Portion 8 & 9 Township is in the operational phase. Vegetation in open spaces should not be disturbed or removed during the operational phase.
Proposed Mitigation Measures	Minimise the area of disturbance by restricting movement to the designated working areas during maintenance.
Proposed Monitoring	Regular site inspection by the Site Manager or Supervisor.
Responsible Body	FULLBRIGHT INVESTMENTS (PTY) LTD/COW

Erosion and sedimentation

Construction phase	
Description	<p>Vegetation clearance and creation of impermeable surfaces could result in erosion in areas across Ongos Portion 8 & 9 Township. The clearance of vegetation will further reduce the capacity of the land surface to slow down the flow of surface water, thus decreasing infiltration, and increasing both the quantity and velocity of surface water runoff. The particles in suspension will be transported towards the north and could increase the sedimentation in the Aretaragas river tributary flowing in the northern direction.</p> <p>The proposed development will increase the amount of impermeable surfaces and therefore decrease the amount of groundwater infiltration. As a result, the amount of storm water during rainfall events could increase.</p>
Proposed Mitigation Measures	Implementation of proper storm water management measures should be conducted as to prevent negative impact on the water courses in the area.
Proposed Monitoring	Regular visual site inspection.
Responsible Party	FULLBRIGHT INVESTMENTS (PTY) LTD /Contractors

Failure of reticulation pipelines

Operational phase	
Description	Potential release of sewage, storm-water, water, into the environment due to pipeline/system failure. As a result, the spillage could be released into the environment and could potentially be a health hazard to surface and groundwater.
Proposed Mitigation Measures	Proper reticulation pipelines and drainage systems should be installed. Regular bulk services infrastructure and system inspection should be conducted.
Proposed Monitoring	Regular visual site inspection.
Responsible Body	FULLBRIGHT INVESTMENTS (PTY) LTD/COW

Nuisance Pollution

Construction phase	
Description	Aesthetics and inconvenience caused to persons using Monte Christo road and surrounding areas. The construction activities would be visible from the Monte Christo Road section within the Township.
Proposed Mitigation Measures	The Technical Manager or Supervisor should maintain tidiness on site at all times. Take cognition when parking vehicles and placing equipment.
Proposed Monitoring	Regular visual inspection.
Responsible Party	FULLBRIGHT INVESTMENTS (PTY) LTD /Contractors

4. CONCLUSIONS

If the above-mentioned management recommendations are properly implemented, it is anticipated that most of the adverse impacts on the environment can be mitigated. An appointed environmental officer/consultant will need to monitor or audit the site throughout construction and operation phase to ensure that the EMP is fully implemented and complied with. The EMP caters for all project phases, but will need to be reviewed during all phases of project, especially when revisions are made to the project development plans.

The Environmental Management Plan should be used as an on-site tool during all phases of the proposed project. Parties responsible for contravention of the EMP should be held responsible for any rehabilitation that may need to be undertaken.

Clearance certificates issued on EMPs are only valid for 3 years and will need to be reviewed and submitted to the Department of Environmental Affairs again for approval.

Matrix Consulting Services



C.E. Ailonga (MSc Env Sci, Wits)
Principal Environmental Scientist
February 2024 Update

APPENDIX A

Environmental Management Plan (EMP)

For the construction and operational phase



ASSOCIATED WASTE WATER TREATMENT PLANT FOR ONGOS PORTION 8 & 9 TOWNSHIP DEVELOPMENT ON FARM ONGOS NO.38

Feb 2024

Compiled by:



Matrix Consulting Services
P.O. Box 25824 Windhoek
Tel: +264-61 224197
Fax: +264-61 212165

Compiled for:

FULLBRIGHT INVESTMENT (PTY) LT
PO Box 20261, Windhoek
Tel:+264 (61) 308106
Fax:+264 (61) 308107

TABLE OF CONTENTS

1.	INTRODUCTION AND BACKGROUND	4
2.	LEGISLATIVE FRAMEWORK	6
3.	ENVIRONMENTAL MANAGEMENT PLAN.....	13
3.1	RESPONSIBILITIES FOR ENVIRONMENTAL MANAGEMENT.....	13
3.2	TRAINING AND INDUCTION	13
3.3	ENVIRONMENTAL INCIDENT REPORTING.....	13
3.4	ENVIRONMENTAL MONITORING.....	13
3.5	EMP ADMINISTRATION	13
3.6	EMP AMENDMENTS	14
3.7	NON COMPLIANCE OF THE EMP	14
3.8	ENVIRONMENTAL REGISTER	14
3.9	ENVIRONMENTAL CONTROL OFFICER	15
3.10	SITE MANAGEMENT	15
3.10.1.1	<i>Access routes and work sites.....</i>	<i>15</i>
3.10.1.2	<i>Fire and safety management</i>	<i>16</i>
3.10.1.3	<i>Staff management.....</i>	<i>16</i>
3.10.1.4	<i>Waste management.....</i>	<i>17</i>
3.10.1.5	<i>Cement and concrete batching.....</i>	<i>17</i>
3.10.1.6	<i>Hydrocarbons management.....</i>	<i>17</i>
3.10.1.7	<i>Information board.....</i>	<i>17</i>
3.10.1.8	<i>Flood management</i>	<i>18</i>
3.10.1.9	<i>Progressive Rehabilitation.....</i>	<i>18</i>
3.10.2	<i>Management of environmental aspects during all phases of the project.....</i>	<i>18</i>
4.	CONCLUSIONS.....	30

GLOSSARY

ENVIRONMENT	an interconnected system of natural and human-made elements such as land, water and air; all living organisms and matter arising from nature, cultural, historical, artistic, economic and social heritage and values.
ENVIRONMENTAL MANAGEMENT	A management process which seeks to ensure, as far as possible, that no avoidable impact is caused to the environment and that when this is unavoidable that the consequences are understood prior to the impact being caused and that the impact is then mitigated as far as possible.
GROUNDWATER	Water located beneath the earth's surface in soil pore spaces and in the fractures of rock formations
HAZARDOUS WASTE	Waste that poses substantial or potential threats to public health or the environment.
MITIGATION	The implementation of practical measures to reduce adverse impacts or enhance beneficial impacts.
NO-GO AREA	Areas where all construction activities and related matters are prohibited.
POLLUTION	Any change in the environment caused by substances, radioactive or other waves; or noise, odours, dust or heat, emitted from any activity, including the storage or treatment of waste or substances, construction and the provision of services, whether engaged in by any person or an organ of state, where that change has an adverse effect on human health or well-being or on the composition, resilience and productivity of natural or managed ecosystems, or on materials useful to people, or will have such an effect in the future.
REHABILITATION	Restoring the disturbed area to more or less the natural set up.
SITE	An area of ground where the Ongos WWTP is to be developed.

1. INTRODUCTION and BACKGROUND

The aim of an operational EMP is to ensure that the proposed waste water treatment plant development as part of the Ongos Portion 8 & 9 Township Development is conducted in an environmentally acceptable and safe manner. This Environmental Management Plan (EMP) serves as a managing tool for all construction and operational activities during the development of a waste water treatment plant, on Ongos Portion 9 of Farm Ongos No.38. Figure 1 below shows the location of the proposed waste water treatment plant.

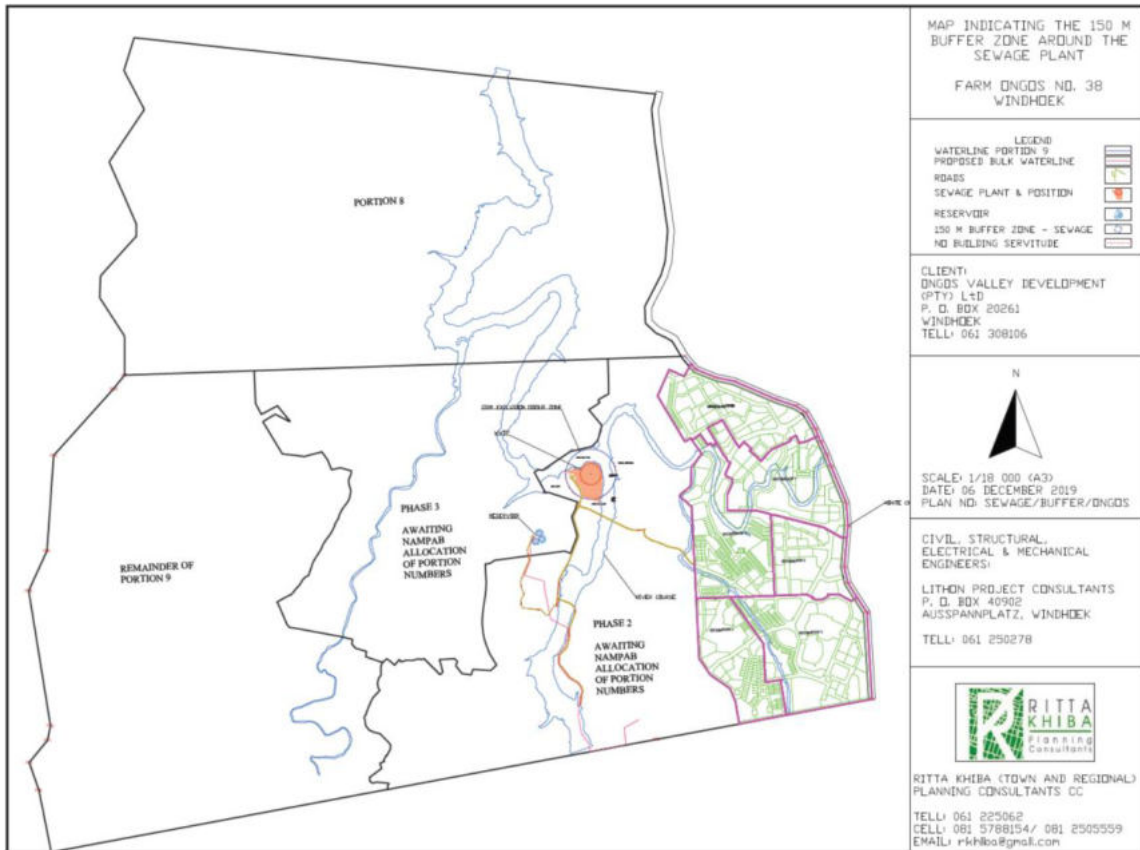

Figure 1: Ongos Portion 8 & 9 Township Waste water treatment plant location

The EMP is developed to outline measures to be implemented in order to minimise adverse environmental degradation associated with this development.

The EMP serves as a guiding tool for the contractors and workforce on their roles and responsibilities concerning environmental management on site, and also provides an environmental monitoring framework for all project phases of the development. This environmental management plan aims to take a pro-active route by addressing potential problems before they occur. The EMP acts as a stand-alone document, which can be used during the various phases of the development.

In this report, the Contractor refers to Fullbright Investment (Pty) Ltd and its sub-contractors.

The purpose of the EMP is to:

- ✓ Train employees and contractors with regard to environmental obligations.
- ✓ Promote and encourage good environmental management practices.

- ✓ Outline responsibilities and roles of Fullbright Investment (Pty) Ltd and its contractors in managing the environment.
- ✓ Describe all monitoring procedures required to identify environmental impacts.
- ✓ Minimise disturbance of the natural environment.
- ✓ Develop waste management practices.
- ✓ Prevent all forms of pollution.
- ✓ Protect the natural environment.
- ✓ Prevent soil and water erosion.
- ✓ Comply with all applicable laws, regulations and standards for environmental protection.

Phases covered by the EMP:
Construction Phase
Operational Phase

The construction phase of the waste water treatment plant development entails:

- ✓ Land clearance
- ✓ Transporting relevant building material and equipment.
- ✓ Installation of associated electrical supply cables.
- ✓ Installation of associated water pipelines.
- ✓ Installation of associated sewer lines.
- ✓ Installation of storm water management system; and
- ✓ Access road construction

The operational phase will entail:

- ✓ Operation and maintenance of the sewer and water reticulation systems and access road.

1.1 Description of the Wastewater Treatment Process (Aquarius Consult)

A new wastewater treatment plant (WWTP) is required for the Ongos Development, on the north-western outskirts of Windhoek. The expected effluent discharge from this new infrastructure will be serviced by a permanent WWTP. For Phase 1 (current) a new plant to serve 10 000 people and with an average dry weather flow (ADWF) of 1 000 m³/d will be provided. This will modular plant, whereby the capacity can be increase as the other extension of the Ongos Township are developed.

The new waste water treatment plant will comply with the requirements of Section 21(1) and 21(2) of the Water Act (Act 54 of 1956) as amended and that the purified water will comply with the Special Standard as laid out in Government Gazette R553 of 5 April 1962.

Additionally, the final effluent will also conform to the envisaged new Water Quality Standards for Effluent, Special Standard, as already defined by the Department of Water Affairs but not yet legalised. Both Standards have been included in Attachment A. The new WWTP as designed is based on New Generation Trickling Filter technology and incorporates all unit processes typically provided for biological treatment of wastewater with subsequent polishing to achieve the General Standard. This includes: screening and grid removal; primary clarifier; anoxic tank; trickling filter; secondary clarifier; humus tank; chlorine contact basin; and sludge dewatering (filter press).

The Department of Water Affairs and Forestry (DWAF) requires that an exclusive area/zone is provided between the WWTP and the nearest dwellings in order to prevent obnoxious odours and vectors from becoming a nuisance to inhabitants close by. At Ongos, this zone will be 150 m wide and this aspect will now be discussed in more detail in the next section. The humus tank will be covered with an extraction fan and vent pipe leading to the underside of the trickling filter – any foul/obnoxious gases will thus be extracted and blown into the trickling filter, which then also acts as scrubber for odour control. A trickling filter is also typically used as scrubber for odour control in other plants (e.g. Ujams WWTP that caters for Elisenheim is also fitted with such a system). Please refer to the design specification by Dr Lempert of Aquairus Consult in the annexures for a detailed summo specification odour zone management.

2. LEGISLATIVE FRAMEWORK

1.1 National Legislative Requirements

The EIA process is undertaken in terms of Namibia's Environmental Management act no.7 of 2007 and the Environmental Assessment Policy of 1995, which stipulates activities that may have significant impacts on the environment. Listed activities require the authorisation from the Ministry of Environment and Tourism (DEA). Section 32 of the Environmental Management Act requires that an application for an environmental clearance certificate be made for the listed activities. The following environmental legislations are relevant to this project:

➤ *The Namibian Constitution*

The Namibian Constitution has a section on principles of state policy. These principles cannot be enforced by the courts in the same way as other sections of the Constitution. But they are intended to guide the Government in making laws which can be enforced.

The Constitution clearly indicates that the state shall actively promote and maintain the welfare of the people by adopting policies aimed at management of ecosystems, essential ecological processes and biological diversity of Namibia for the benefit of all Namibians, both present and future.

➤ ***Atmosphere Pollution Prevention Ordinance (1976)***

This Ordinance generally provides for the prevention of the pollution of the atmosphere. Part IV of this ordinance deals with dust control. The Ordinance is clear in requiring that any person carrying out an industrial process which is liable to cause a nuisance to persons residing in the vicinity or to cause dust pollution to the atmosphere, shall take the prescribed steps or, where no steps have been prescribed, to adopt the best practicable means for preventing such dust from becoming dispersed and causing a nuisance.

Line Ministry: Ministry of Environment and Tourism

(Contact: Dr. Freddy Sikabongo, Tel: 061-284 2715, e-mail: freddy@met.na)

➤ ***Water Resources Management Act of Namibia (2004)***

This act repealed the existing South African Water Act No.54 of 1956 which was used by Namibia. This Act ensures that Namibia's water resources are managed, developed, protected, conserved and used in ways which are consistent with fundamental principles depicted in section 3 of this Act. Part IX regulates the control and protection of groundwater resources. Part XI, titled Water Pollution Control, regulates discharge of effluent by permit. Thus developers are required to efficiently plan for sewage disposal.

Line Ministry: Ministry of Agriculture, Water Affairs and Forestry

(Contact: Ms Elizabeth Amagola, Tel: 061-208 7719)

➤ ***Water Act No.54 of 1956***

This Act provides for Constitutional demands including pollution prevention, ecological and resource conservation and sustainable utilisation. In terms of this Act, all water resources are the property of the State and the EIA process is used as a fundamental management tool.

A water resource includes a watercourse, surface water, estuary or aquifer, and, where relevant, its bed and banks. A watercourse means a river or spring; a natural channel in which water flows regularly or intermittently; a wetland lake or dam, into which or from which water flows; and any collection of water that the Minister may declare to be a watercourse. Permits are required in terms of the Act for the undertaking of the following activities relevant to the proposed project:

- ✓ Discharge of waste or water containing waste into a water resource through a pipe, canal, sewer, sea outfall or other conduit in terms of Section 21 (f); and
- ✓ Disposal of waste in a manner that may detrimentally impact on a water resource in terms of Section 21 (g).

Line Ministry: Ministry of Agriculture, Water Affairs and Forestry

(Contact: Ms Elizabeth Amagola, Tel: 061-208 7719)

➤ ***The Draft Wetland Policy (1993)***

Requires that any wetlands and its associated hydrological functions form a part, to be managed in such a way that their biodiversity, vital ecological functions and life support systems are protected for the benefit of present and future generations.

Line Ministry: Ministry of Environment and Tourism

(Contact: T. Mufeti, Tel: 061-284 2715)

➤ ***Environmental Assessment Policy of Namibia (1995)***

Environmental Assessments (EA's) seek to ensure that the environmental consequences of development projects and policies are considered, understood and incorporated into the planning process, and that the term ENVIRONMENT (in the context of IEM and EA's) is broadly interpreted to include biophysical, social, economic, cultural, historical and political components.

All listed policies, programmes and projects, whether initiated by the government or the private sector, should be subjected to the established EA procedure as set out in Figure 2.

Line Ministry: Ministry of Environment and Tourism

(Contact: T. Mufeti, Tel: 061-284 2715)

➤ ***Forestry Act (No.12 of 2001)***

This Act makes provision for the protection various plant species. Harvesting permits are required from the Directorate of Forestry to clear certain protected vegetation species from the site.

Line Ministry: Ministry of Agriculture, Water Affairs and Forestry

(Contact: Andries Uugwanga, Tel: 062-501925)

➤ ***Sewerage and Drainage Regulations(amendments) Local authorities act, section 23 (1992).***

The regulations makes provision for proper construction of pipelines in drainage lines. The regulations also stipulate the prevention of pollution and environmental damage caused by improper construction of sewerage and water pipelines in drainage lines.

Line Ministry: Ministry of Regional and Local Government, Housing and Rural Development

➤ ***Soil Conservation Act (No.76 of 1969).***

The Act advocates for the Prevention and combating of soil erosion, conservation, improvement and manner of use of soil and vegetation, and protection of water resources.

(Contact: T. Mufeti, Tel: 061-284 2715)

➤ ***Environmental Management Act No.7 of 2007***

This Act provides a list of projects requiring an Environmental Assessment. It aims to promote the sustainable management of the environment and the use of natural resources and to provide for a process of assessment and control of activities which may have significant effects on the environment; and to provide for incidental matters.

The Act defines the term “*environment*” as an interconnected system of natural and human-made elements such as land, water and air; all living organisms and matter arising from nature, cultural, historical, artistic, economic and social heritage and values.

The Environmental Management Act has three main purposes:

- (a) to make sure that people consider the impact of activities on the environment carefully and in good time.
- (b) to make sure that all interested or affected people have a chance to participate in environmental assessments
- (c) to make sure that the findings of environmental assessments are considered before any decisions are made about activities which might affect the environment

The development of an waste water treatment plant is a ‘*listed activity*’ as per the *List of Activities requiring Environmental Clearance* (Government Notice 29 of 6 February 2012) and accordingly requires an Environmental Impact Assessment (EIA) to be conducted.

Line Ministry: Ministry of Environment and Tourism

(Contact: T. Mufeti, Tel: 061-284 2715)

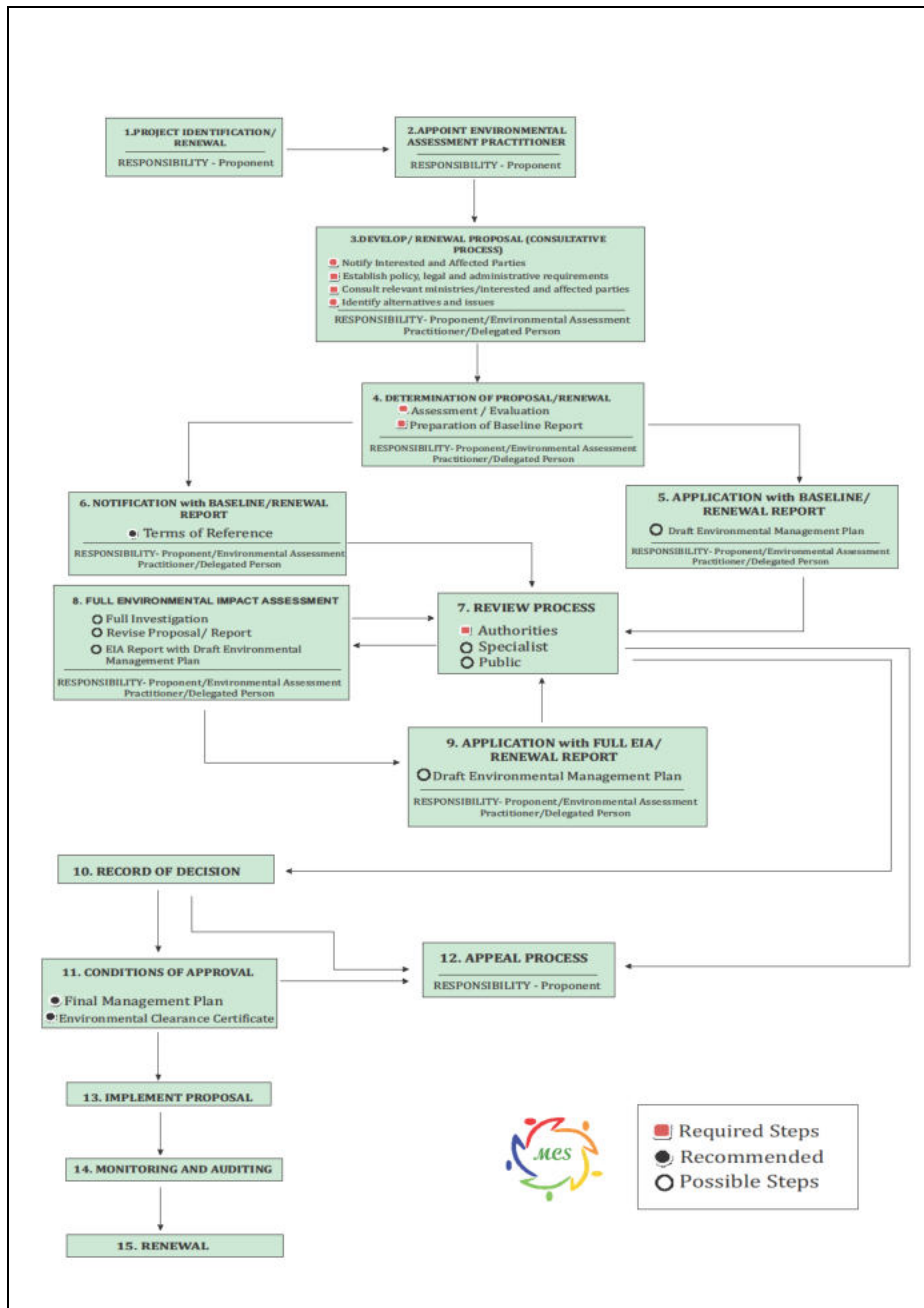

Figure 2. Environmental Assessment Procedure of Namibia (Adapted from the Environmental Assessment Policy of 1995)

➤ **Draft Pollution Control and Waste Management Bill**

The proposed project of Ongos waste water treatment plant, applies to Parts 2 and 7 of the Bill.

Part 2 stipulates that no person shall discharge or cause to be discharged any pollutant to the air from a process except under and in accordance with the provisions of an air pollution licence issued under section 23. It further provides for procedures to be followed in licence application, fees to be paid and required terms of conditions for air pollution licences.

Part 7 states that any person who sells, stores, transports or uses any hazardous substances or products containing hazardous substances shall notify the competent

authority, in accordance with sub-section (2), of the presence and quantity of those substances.

➤ ***Hazardous Substances Ordinance No. 14 of 1974***

The Ordinance applies to the manufacture, sale, use, disposal and dumping of hazardous substances, as well as their import and export and is administered by the Minister of Health and Social Welfare. Its primary purpose is to prevent hazardous substances from causing injury, ill-health or the death of human beings.

Line Ministry: Ministry of Health and Social Services

➤ ***Public Health Act 36 of 1919 and Subsequent Amendments***

The Act, with emphasis to Section 119 prohibits the presence of nuisance on any land occupied. The term nuisance for the purpose of this EIA is specifically relevant specified, where relevant in Section 122 as follows:

- ✓ any dwelling or premises which is or are of such construction as to be injurious or dangerous to health or which is or are liable to favour the spread of any infectious disease;
- ✓ any area of land kept or permitted to remain in such a state as to be offensive, or liable to cause any infectious, communicable or preventable disease or injury or danger to health; or
- ✓ any other condition whatever which is offensive, injurious or dangerous to health.

Potential impacts associated with the development of Ongos Portion 8 & 9 project and its associated infrastructure are expected to include dust, air quality impacts, noise nuisance and smoke emissions.

Line Ministry: Ministry of Health and Social Services

➤ ***National Heritage Act (No.76 of 1969).***

The Act calls for the protection and conservation of heritage resources and artefacts. Should any archaeological material, e.g. old weapons, coins, bones found during the construction, work should stop immediately and the National Heritage Council of Namibia must be informed as soon as possible. The Heritage Council will then decide to clear the area or decide to conserve the site or material.

(Contact: Rev. Salomon April, Tel: 061-244375, National Heritage Council of Namibia)

1.2 International Conventions and Regulations

Article 144 of the Namibian Constitution states that “the general rules of public international law and international agreements binding upon Namibia form part of the law of Namibia.” This means that all the international agreements that Namibia signed become part of the law of our country. These laws and/or agreements are:

- ✓ Convention on Biological Diversity, 1992;
- ✓ United Nations Framework Convention on Climate Change, 1992;
- ✓ Kyoto Protocol on the Framework Convention on Climate Change, 1998;
- ✓ Stockholm Convention of Persistent Organic Pollutants, 2001.

3. ENVIRONMENTAL MANAGEMENT PLAN

3.1 Responsibilities for environmental management

Fullbright Investment (Pty) Ltd will be responsible for environmental control on site during the construction and operational phase. It is very important a pre-work briefing meeting be held at all times to reach an agreement on specific roles of various parties and penalties for non-compliance.

3.2 Training and induction

Fullbright Investment (Pty) Ltd is bound to be responsible for ensuring that environmental awareness education of all employees and contractors is done satisfactorily. Fullbright Investment (Pty) Ltd should ensure that employees and contractors are made aware of the environmental requirements of the project.

The EMP should form part of the Terms of Reference for all contractors, sub-contractors and suppliers. All contractors, sub-contractors and suppliers will have to sign an agreement to assure that they understood the EMP and that they will comply. All senior staff should familiarise themselves with the full contents of the EMP and its implications. Senior staffs (Foreman/Supervisor) are expected to train and assist the rest of the employees on the contents of the EMP.

3.3 Environmental incident reporting

All environmental incidents occurring at the proposed site will be recorded. The incident report will have to include time, date, location, and nature of the incident, extent of the incident, actions taken, and personnel involved.

All complaints received from the neighbouring community should be directed to the Project Manager of Fullbright Investment (Pty) Ltd and channelled to the appointed ECO officer. Fullbright Investment (Pty) Ltd Management should be able to respond to the complainant within a week (even if pending further investigation). It is important that the issues raised are considered and that the complainant feels that their concerns have been addressed to and wherever possible actions taken to address these. All complaints should be entered in the environmental register and all responses and actions taken to address these should be recorded.

3.4 Environmental monitoring

Periodic environmental monitoring must be taken on a regular basis. Monitoring should be done in order to ensure compliance with all aspects of the EMP. Findings should be liaised with to all responsible officers as chain command.

3.5 EMP administration

Copies of this EMP shall be kept at the site office and should be distributed to all senior staff members, including those of the contractors.

3.6 EMP amendments

The EMP amendments can only be made with the approval of the ECO officer and ultimately the DEA. Amendments to the EMP should be liaised to all employees and contractors.

3.7 Non compliance of the EMP

Problems may occur in carrying out mitigation measures or monitoring procedures that could result in non-compliance of the EMP. The responsible personnel should encourage staff to comply with the EMP, and address acts of non-compliance and penalties.

Fullbright Investment (Pty) Ltd is responsible for reporting non-conformance with the EMP, to the ECO officer. The management of Fullbright Investment (Pty) Ltd, in consultation with the ECO officer must, thereafter, undertake the following activities:

- ✓ Investigate and identify the cause of non-conformance.
- ✓ Report matters of non-conformance to Fullbright Investment (Pty) Ltd (depending on the severity of the incident).
- ✓ Implement suitable corrective action as well as prevent recurrence of the incident.
- ✓ Assign responsibility for corrective and preventative action.
- ✓ Any corrective action taken to eliminate the causes of non-conformance shall be appropriate to the magnitude of the problems and commensurate with the environmental impact encountered.

3.8 Environmental Register

An environmental register should be kept on site in which incidents related to actual impacts are recorded. This will include information related to incidents as spillages, dust generation and complaints from adjacent neighbours. It should also contain information relating to actions taken. Any party on site may complete the register, however, it is envisaged that the Technical Manager, the contractor and the ECO officer will be the main contributors, and who will also be the main parties involved in suggesting mitigation measures.

3.9 Environmental Control Officer

The Environmental Control Officer for the site is an independent environmental consultant appointed by Fullbright Investment (Pty) Ltd to monitor and review the on-site environmental management and implementation of this EMP.

Duties of the ECO officer:

- ✓ The identification of potential environmental impacts, prior to the onset of decommissioning. A site visit may also be required prior to site development. This would be carried out in consultation with the Technical Manager.
- ✓ Providing of an environmental register at the site to be filled in by any person reporting an environmental incident, issue or concern and inspected by the ECO officer on a regular basis to check for issues raised and actions taken.
- ✓ Ensuring that the EMP conditions are adhered to at all times and taking action.
- ✓ Ensuring that environmental impacts are kept to a minimum.
- ✓ Reviewing and approving method statements in consultation with the Technical Manager.
- ✓ Reporting to Fullbright Investment (Pty) Ltd and the Technical Manager on a regular basis and advising of any major environmental impacts. Attending the site meetings (when necessary)
- ✓ Inspecting the site and surrounding areas regularly, and monitoring an ongoing environmental awareness program in conjunction with the Technical Manager.
- ✓ Requesting the removal of people and/or equipment not complying with the specifications of EMP.
- ✓ Keeping both a written and photographic record of progress on site from an environmental perspective, and an ad hoc record of all environmental incidents
- ✓ Undertaking continual review of the EMP and submitting a report to the relevant stakeholders.
- ✓ The ECO officer will submit all written instructions and verbal requests to Fullbright Investment (Pty) Ltd via the Technical Manager and Project Engineer.

3.10 Site Management

Areas outside this designated working zone shall be considered “no go” areas. The offloading zones must be clearly demarcated when offloading goods to enhance safety around the project location.

3.10.1.1 Access routes and work sites

During the construction phase, road transport trucks will access the project location via Monte Christo road and existing municipal roads/tracks. No new tracks/roads shall be established and only existing roads may be used and those that are planned. Work sites shall be clearly demarcated and road signs erected

were needed. The general public should not have unauthorised/uncontrolled access to the project location during this phase.

Vehicle access will be limited to one or two entrances to facilitate control. Access must be of a high standard to prevent unauthorised access from entering the site.

The entrance will be manned during the operation hours; and access routes will be closed to prevent unauthorised entry. A notice board, in two languages, must be erected at the entrance and must state entrance requirements and operating hours of the site, the operator/responsible person and emergency telephone numbers. Suitable signs must also be erected on the approach roads and on-site, to direct drivers and to control speed.

Road access to the working face of the waste water treatment plant development must be maintained at all times in a manner suitable to accommodate vehicles normally expected to use the facility. Roads must be regularly graded and wetted to control dust, where necessary.

Furthermore, on-going controls, such as fencing and policing, must be implemented.

3.10.1.2 Fire and safety management

All electrical installations, wiring and systems at the project location, must be approved by a qualified electrician who will issue a Certificate of Compliance.

Proper handling, storage, use and disposal of any hazardous waste (e.g. hydrocarbons, paint, batteries, radioactive waste e.t.c) should be conducted. Hydrocarbons are volatile under certain conditions and their vapours in specific concentrations are flammable. If precautions are not taken to prevent their ignition, fire and subsequent safety risks may arise.

No uncontrolled fire, whether for cooking or any other purpose, is to be made at the project location during both the construction and operation phases by the contractor. The Contractor shall take all reasonable measures and active steps to avoid increasing the risk of fire through activities on site and prevent the accidental occurrence or spread of fire; and shall ensure that there is sufficient fire-fighting equipment on site at all times. This equipment shall include fire extinguishers. The Contractor should be prepared for such events.

3.10.1.3 Staff management

The Contractor must ensure that their employees have suitable personal protective equipment and properly trained in fire fighting and first aid. Training records must be kept for future references.

3.10.1.4 Waste management

Waste will be generated in the form of rubble, cement bags, pipe and electrical wire cuttings. Contaminated soil due to oil leakages, lubricants and grease from the construction equipment and machinery may also be generated during the construction phase.

The oil leakages, lubricants and grease must be addressed. Contaminated soil must be removed and disposed off at the hazardous landfill. The contractor must provide containers on-site, to store any hazardous waste produced. Regular inspection and housekeeping procedure monitoring should be maintained by the contractor.

Waste in the form of solid waste from households, businesses and institutions will also be generated during the operational phase. Waste will be removed and disposed off at a waste disposal site by Fullbright Investment (Pty) Ltd or its contractors.

Fullbright Investment (Pty) Ltd will make provisions for waste skips around these extensions like the rest of the suburbs in Windhoek.

3.10.1.5 Cement and concrete batching

Concrete mixing directly on the ground shall not be allowed and shall take place on an impermeable surface. All run-off from batching areas shall be strictly controlled, and cement contaminated water shall be collected, stored and disposed of at a suitable waste disposal facility.

3.10.1.6 Hydrocarbons management

If any spillage occurs, contaminated soil shall be collected in a holding tray or drum and which will then be disposed at a **hazardous waste disposal site**. Any spillage of more than 200 litres must be reported to the Ministry of Mines and Energy as per the Petroleum Products Act.

The Contractor shall take all reasonable measures to prevent surface or groundwater pollution from the release of oils and fuels.

3.10.1.7 Information board

The Contractor will be responsible for erecting information boards on site. The number and locations of these boards shall be agreed upon by the ECO officer.

The contents of the information board shall be provided by the Technical Manager and will essentially be to advise the public of the construction activity and the prohibition on entering certain areas. The information board shall also provide the contact number of the ECO, to ensure that the public can access

relevant information and lodge any complaints during the construction phase of the waste water treatment plant development.

3.10.1.8 Flood management

The waste water treatment plant development will be designed in such a way that surface water run-off is well developed. Storm water management of the waste water treatment plant development should be a key aspect of flood management at the waste water treatment plant. All culverts should be kept clean to allow storm water to flow freely.

3.10.1.9 Progressive Rehabilitation

Rehabilitation must commence as soon as possible on areas where construction has taken place or no further development is to take place, i.e. on completed excavations, soil/rock cutting hips, slopes etc.

3.10.2 Management of environmental aspects during all phases of the project

Groundwater

Construction phase	
Description	<p>Groundwater quality could be possibly impacted through leachate of oil leakages, diesel, lubricants and grease from the heavy-duty equipment and machinery utilised during construction phase. Care must be taken to avoid contamination of soil and groundwater. Drip trays must be used when removing oil from machinery.</p> <p>Run-off from overflowing onsite temporary sewage systems might transport the effluent to areas where geological structures are present. Inflow into these structures would cause a pollution thread. There are no major faults on the project location.</p> <p>There is a slight potential health impact on groundwater users in the area. Potential impact on the natural environment from the polluted groundwater also exists. In general, impact on groundwater due to the construction of the waste water treatment plant development is considered to be minimal through proper management practices.</p>
Proposed Mitigation Measures	<p>Prevent spillages of any chemical or fuel. Use drip trays when doing maintenance on machinery. Maintenance should be done on dedicated areas with linings or concrete floor. No maintenance of machinery may be done at the project location. Implementation of sound and proper management practices.</p>
Proposed Monitoring	<p>Regular visual inspection.</p>
Responsible Party	<p>Fullbright Investment (Pty) Ltd/ Contractors</p>

Operational phase	
Description	<p>Spillages and/or leakages of various possible contaminants might occur due to failure of reticulation pipelines or the trickling filter plant. Contaminated soil might pose a risk to surface water.</p> <p>Potential impact on the natural environment from possible polluted groundwater also exists. The area is subjected to structures, which might act as preferential pathways for any contaminants entering the saturated zone.</p>
Proposed Mitigation Measures	<p>The risk can be lowered further through the use of suitable and adequate SANS approved piping material; and installation should be done by certified installers/technicians. All surface spillages and leakages must be cleaned up immediately. Proper back-up containment structures should be constructed to avoid any possible leakages.</p> <p>The presence of an emergency response plan and suitable equipment is advised, so as to react to any spillage or leakages properly and efficiently.</p>
Proposed Monitoring	Groundwater monitoring sampling for pollution, upstream and downstream of the plant.
Responsible Party	Fullbright Investment (Pty) Ltd

Surface Water

Construction phase	
Description	<p>Contamination of surface water might occur through oil leakages, diesel, lubricants and grease from the heavy-duty equipment and machinery during the construction phase.</p> <p>Surface runoff emanating from overflowing and/or leakages from chemical , temporary sewage storage and reticulation pipeline systems might reach water bodies. Potential Health problems caused by viruses, bacteria and parasites found in the effluent would be the main concern from this pathway.</p> <p>Potential health impact on surface water users and on the natural environment associated with the nearby streams and rivers. Surface runoff from the site is expected in a westerly direction.</p>
Proposed Mitigation Measures	<p>Machinery should not be serviced on site to avoid spills. All spills should be cleaned up as soon as possible. Hydrocarbon/chemical contaminated soil; clothing or equipments should not be washed within 25m of any water body (Aretaragas River and its tributaries).</p>
Proposed Monitoring	Regular visual inspection. Surface water quality monitoring in cases of evident pollution.
Responsible Party	Fullbright Investment (Pty) Ltd /Contractors

Operational phase	
Description	<p>Spillages and/or leakages of various possible contaminants might occur due to failure of associated reticulation pipelines or the trickling filter plant. Contaminated soil might pose a risk to surface water. All spills should be cleaned up as soon as possible. An emergency plan should be in place on how to deal with spillages and leakages during this phase.</p> <p>Potential health impact on surface water users and on the natural environment associated with the river channels in the area do exist. This may result in socio-economic impacts on surface water users.</p>
Proposed Mitigation Measures	<p>Drip trays and/or plastic sheeting should be used to contain any leaks emanating from the heavy-duty machinery and fleet. The plant should be equipped with back-up storage capacity to accommodate waster water in cases of breakdown or maintenance.</p> <p>All spills should be cleaned up as soon as possible. The presence of an emergency response plan and suitable equipment is advised, so as to react to any spillage or leakages properly and efficiently.</p>
Proposed Monitoring	Surface water quality monitoring via monitoring boreholes upstream and downstream of the plant.
Responsible Party	Fullbright Investment (Pty) Ltd

Air Quality (including Dust Pollution)

Construction phase	
Description	<p>Dust will be generated during the construction and installation of bulk services, and problems thereof are expected to be site specific. Dust is expected to be worse during the winter months when strong winds occur. Release of various particulates from the site during the construction phase and exhaust fumes from vehicles and machinery related to the construction of bulk services are also expected to take place. Dust is regarded as a nuisance as it reduces visibility, affects the human health and retards plant growth.</p>
Proposed Mitigation Measures	<p>It is recommended that regular dust suppression be included in the construction activities, when dust becomes an issue. No unnecessary revving of engines or operation of vehicles is allowed. In general, the waste water treatment plant project is envisaged to have minimal impacts on the surrounding air quality during the construction phase.</p>
Proposed Monitoring	Regular visual inspection.
Responsible Party	Fullbright Investment (Pty) Ltd /Contractors

Operational phase	
Description	<p>Vehicles that will be accessing waste water treatment plant will contribute to the release of hydrocarbon vapours, carbon monoxide and sulphur oxides into the air.</p> <p>Possible release of sewer odour, due to sewer system failure or maintenance might also occur. All maintenance of bulk services of the waste water treatment plant procedures have to be designed to enable environmental protection.</p>
Proposed Mitigation Measures	<p>Vehicle idling time shall be minimised by putting up educative signs.</p> <p>The Proponent should ensure that the waste water treatment machinery and equipment are designed in such a way or contain technologies that can help to control or minimize odour. Some options, such as adding chemicals to the water or using deodorizing misting systems, reportedly work well to a certain extent.</p> <p>A sudden change in wastewater composition or weather can cause the odour to intensify. Fine-tuning the wastewater treatment process itself is another odour control tactic, however this can be complex and costly. Wastewater treatment plants can be sealed off to contain the source of odour with an industrial-grade cover, thereby preventing the diffusion of odour vapours. No residence within the 150m odour zone.</p>
Proposed Monitoring	Regular visual inspection.
Responsible Body	Fullbright Investment (Pty) Ltd

Health and Safety

Construction phase	
Description	<p>Safety issues could arise from the earthmoving equipment and tools that will be used on site during the construction phase. This increases the possibility of injuries and the contractor must ensure that all staff members are made aware of the potential risks of injuries on site. The presence of equipment lying around on site may also encourage criminal activities (theft).</p> <p>No open flames, smoking or any potential sources of ignition should be allowed at the project location. Signs such as 'NO SMOKING' must be prominently displayed in parts where inflammable materials are stored on the premises.</p>
Proposed Mitigation Measures	<p>Equipment and machinery operators should be equipped with ear protection equipment. Operations should be strictly between 07H00 to 19H00. First aid and safety awareness training for contractors.</p> <p>Ensure the general safety and security at all times by providing day and night security guards and adequate lighting within and around the premises. The staff must be properly trained on safety and health issues of the project. Workers should be fully equipped with personal protective equipment gear.</p>
Proposed Monitoring	Safety procedures evaluation. Health and safety incident monitoring.
Responsible Party	Fullbright Investment (Pty) Ltd /Contractors

Operational phase	
Description	<p>A number of health and safety threats exist during operational activities of Ongos Portion 8 & 9. Individuals in the community can suffer from noise from maintenance activities around this township and its associated infrastructure. Accidents on roads as a result of increased traffic and deteriorated.</p> <p>The contractors are advised to ensure that proper personal protective gear and first aid kits are available, at all times. Workers should also be properly trained in first aid and safety awareness.</p>
Proposed Mitigation Measures	Operators and maintenance contractors must be properly trained on safety and health issues. Workers should be fully equipped with personal protective equipment gear.
Proposed Monitoring	Regular inspection and incident monitoring report evaluation.
Responsible Body	Fullbright Investment (Pty) Ltd

Noise Impact

Construction phase	
Description	<p>An increase of ambient noise levels at the WWTP site is expected due to the construction activities. Noise pollution due to heavy-duty equipment and machinery will be generated.</p> <p>It is not expected that the noise generated during construction will impact any third parties severely.</p>
Proposed Mitigation Measures	<p>Sensitive construction vehicle drivers and machinery operators to switch off engines of vehicles or machinery not being used. Ensure engines of machinery are fitted with mufflers. Equipment and machinery operators should be equipped with ear protection equipment. Operations should be strictly between 07H00 to 19H00.</p>
Proposed Monitoring	<p>Strict operational times. Regular inspection.</p>
Responsible Party	<p>Fullbright Investment (Pty) Ltd /Contractors</p>

Operational phase	
Description	<p>Noise pollution already exists around the site in the form of noise generated from vehicles frequenting the existing Monte Christo road and other municipal roads and tracks. Noise pollution due to this projecting the operational phase is expected to be mainly from generators or pumps, road maintenance machinery during maintenance.</p>
Proposed Mitigation Measures	<p>Ensure that generator engines are fitted with mufflers. Operators working in close proximity to the generators should be equipped with ear protection equipment, when noise becomes an issue. Observation of on-site noise levels by the Manager or Supervisor of Bulk Services Maintenance Department.</p>
Proposed Monitoring	<p>Observation of on-site noise levels.</p>
Responsible Body	<p>Fullbright Investment (Pty) Ltd</p>

Waste Generation

Construction phase	
Description	This can be in a form of rubble, cement bags, pipe and electrical wire cuttings. Contaminated soil due to oil leakages, lubricants and grease from the construction equipment and machinery may also be generated during the construction phase.
Proposed Mitigation Measures	<p>The oil leakages, lubricants and grease must be addressed. Contaminated soil must be removed and disposed off at the nearest hazardous landfill. The contractor must provide containers on-site, to store any hazardous waste produced before it is transported to an appropriate hazardous landfill.</p> <p>Ensure that no excavated soil, refuse or building rubble generated on site are not placed, dumped or deposited on adjacent/surrounding properties or land.</p>
Proposed Monitoring	Regular inspection and housekeeping procedure monitoring. Observation of site appearance by the manager.
Responsible Party	Fullbright Investment (Pty) Ltd /Contractors

Operational phase	
Description	Waste in the form of contaminated soil, rubble, biosolids and domestic waste. Littering along access roads may also be produced during the operational phase.
Proposed Mitigation Measures	Waste must be removed and disposed off at a landfill by Fullbright Investment (Pty) Ltd and or its Waste Removal Contractors.
Proposed Monitoring	Regular visual inspection.
Responsible Body	Fullbright Investment (Pty) Ltd

Traffic

Construction phase	
Description	<p>The waste water treatment plant activities are expected to have a minor impact on the movement of traffic along the Monte Christo road and township internal roads. No diversion of traffic or closure of roads is expected.</p> <p>Speed limit warning signs must be erected to minimise accidents. Heavy-duty vehicles and machinery must be tagged with reflective signs or tapes to maximise visibility and avoid accidents.</p>
Proposed Mitigation Measures	<p>It is recommended that if the need arises for traffic diversion or road closure, The contractor should liaise with the Fullbright Investment (Pty) Ltd . Speed limit and site warning signs must be erected to minimise accidents. Construction vehicles must be tagged with reflective signs or tapes to maximise visibility of the vehicles and avoid accidents.</p>
Proposed Monitoring	<p>Observations of the traffic flow on Monte Christo road and surrounding municipal roads.</p>
Responsible Party	<p>Fullbright Investment (Pty) Ltd /Contractors</p>

Operational phase	
Description	<p>Traffic around the waste water treatment plant should be monitored, to avoid traffic congestion in the area during maintenance. Speed limits and road signs as set out by Local Traffic Department should be adhered to in order to minimise accidents.</p>
Proposed Mitigation Measures	<p>It is advisable that traffic flow mitigation measures be implement to ease traffic flow around the new WWTP.</p>
Proposed Monitoring	<p>Observations of the traffic flow on Monte Christo Road and surrounding municipal roads.</p>
Responsible Body	<p>Fullbright Investment (Pty) Ltd</p>

Ecological impacts

Construction phase	
Description	The proposed waste water treatment plant development lies in an already disturbed area, which is free of many conservation worthy vegetation and fauna. Land will be cleared, leaving the big trees to maintain the vegetation within the Ongos Township. However, impacts on fauna and flora are expected to be minimal. Alien invasive species like <i>Prosopis glandulosa</i> and <i>Rhigozium dichotomum</i> should not be conserved and must be cleared and burned in a confined area to avoid further invasion. Vegetation in open spaces may not be disturbed at all.
Proposed Mitigation Measures	Disturbance of areas outside the designated working zone is not allowed.
Proposed Monitoring	Regular site inspection by the Site Manager or Supervisor.
Responsible Party	Fullbright Investment (Pty) Ltd /Contractors

Operational phase	
Description	No impacts are expected from the proposed waste water treatment plant in the operational phase. Vegetation in open spaces should not be disturbed or removed during the operational phase. Vegetation in the surrounding open spaces must be conserved or incorporated in future development on open spaces.
Proposed Mitigation Measures	Minimise the area of disturbance by restricting movement to the designated working areas during maintenance.
Proposed Monitoring	Regular site inspection by the Site Manager or Supervisor.
Responsible Body	Fullbright Investment (Pty) Ltd

Erosion and sedimentation

Construction phase	
Description	<p>Vegetation clearance and creation of impermeable surfaces could result in erosion in areas around the WWTP. The clearance of vegetation will further reduce the capacity of the land surface to slow down the flow of surface water, thus decreasing infiltration, and increasing both the quantity and velocity of surface water runoff.</p> <p>The proposed development will increase the amount of impermeable surfaces and therefore decrease the amount of groundwater infiltration. As a result, the amount of storm water during rainfall events could increase.</p>
Proposed Mitigation Measures	Implementation of proper storm water management measures should be conducted as to prevent negative impact on the water courses in the area.
Proposed Monitoring	Regular visual site inspection.
Responsible Party	Fullbright Investment (Pty) Ltd /Contractors

Failure of reticulation pipelines

Operational phase	
Description	<p>Potential release of sewage, storm-water, water, into the environment due to the WWTP or pipeline/system failure. As a result, the spillage could be released into the environment and could potentially be a health hazard to surface and groundwater.</p>
Proposed Mitigation Measures	Proper reticulation pipelines and drainage systems should be installed. Regular bulk services infrastructure and system inspection should be conducted.
Proposed Monitoring	Regular visual site inspection.
Responsible Body	Fullbright Investment (Pty) Ltd

Nuisance Pollution

Construction phase	
Description	Aesthetics and inconvenience caused to persons using Monte Christo road and surrounding areas. The construction activities would be visible from those roads.
Proposed Mitigation Measures	The Technical Manager or Supervisor should maintain tidiness on site at all times. Take cognition when parking vehicles and placing equipment.
Proposed Monitoring	Regular visual inspection.
Responsible Party	Fullbright Investment (Pty) Ltd /Contractors

4. CONCLUSIONS

If the above-mentioned management recommendations are properly implemented, it is anticipated that most of the adverse impacts on the environment can be mitigated. An appointed environmental officer/consultant will need to monitor or audit the site throughout construction and operation phase to ensure that the EMP is fully implemented and complied with. The EMP caters for all project phases, but will need to be reviewed during all phases of project, especially when revisions are made to the project development plans.

The Environmental Management Plan should be used as an on-site tool during all phases of the proposed project. Parties responsible for contravention of the EMP should be held responsible for any rehabilitation that may need to be undertaken.

Clearance certificates issued on EIA/EMPs are only valid for 3 years and will need to be reviewed and submitted to the Department of Environmental Affairs again for approval.

Matrix Consulting Services

Chris Ailonga (MSc Env Sci, WITS)
Environmental Specialist
February 2024

APPENDIX B



AQUARIUS CONSULT CC

Reg. No.: CC/2010/3052

ONGOS WASTEWATER TREATMENT PLANT

EXCLUSIVE AREA/ZONE AROUND WASTEWATER TREATMENT PLANT

1. BACKGROUND

A new wastewater treatment plant (WWTP) is required for the Ongos Development, on the north-western outskirts of Windhoek. The expected effluent discharge from this new infrastructure will be serviced by a permanent WWTP. For Phase 1 (current) a new plant to serve 10 000 people and with an average dry weather flow (ADWF) of 1 000 m³/d will be provided.

The new waste water treatment plant will comply with the requirements of Section 21(1) and 21(2) of the Water Act (Act 54 of 1956) as amended and that the purified water will comply with the **Special Standard** as laid out in Government Gazette R553 of 5 April 1962. Additionally, the final effluent will also conform to the envisaged new Water Quality Standards for Effluent, **Special Standard**, as already defined by the Department of Water Affairs but not yet legalised. Both Standards have been included in Attachment A.

The new WWTP as designed is based on New Generation Trickling Filter technology and incorporates all unit processes typically provided for biological treatment of wastewater with subsequent polishing to achieve the General Standard. This includes: screening and grid removal; primary clarifier; anoxic tank; trickling filter; secondary clarifier; humus tank; chlorine contact basin; and sludge dewatering (filter press).

The Department of Water Affairs and Forestry (DWAFF) requires that an exclusive area/zone is provided between the WWTP and the nearest dwellings in order to prevent obnoxious odours and vectors from becoming a nuisance to inhabitants close by. At Ongos, this zone will be 150 m wide and this aspect will now be discussed in more detail in the next section.

2. EXCLUSIVE ZONE

For treatment plants that incorporate a primary clarifier, such as Ongos WWTP, the Code of Practice from DWAFF dealing specifically with Trickling Filters (DWAFF, Vol. 3, 2010) specifies for the exclusive zone (quoted from Vol. 3):

“If a septic tank or primary clarifier is employed as primary treatment process, this distance may be reduced to 250 m. Latter distance may even be further reduced but is subject to odour control and needs approval by DWAFF.”

Odour control. Whereas Trickling Filters do not emit obnoxious odours when operating properly, utmost care was taken during the detail design stage to capture and/or prevent odours being emitted:

- The humus tank will be covered with an extraction fan and vent pipe leading to the underside of the trickling filter – any foul/obnoxious gases will thus be extracted and blown



into the trickling filter, which then also acts as scrubber for odour control. A trickling filter is also typically used as scrubber for odour control in other plants (e.g. Ujams WWTP is also fitted with such a system);

- The room housing the dewatering belt press will be enclosed and also be provided with a fan and vent pipe discharging to the underside of the trickling filter, similarly as described above;
- The attached Process & Instrumentation Drawings (P&ID – Dwg No.: 1906.002.ONG-001) in Appendix B shows how air will be extracted from the humus tank and room housing the filter and discharged to the trickling filter, which then acts as scrubber to remove obnoxious odours from the air/gas.

There are many trickling filters in operation in Namibia that do not have even the above-mentioned foul air extraction systems included, and who are built much closer to the inhabitants than 150 m. Typically, some recently completed, big plants/examples of a comparable size such as Ongos WWTP include the Oshikango (3 Ml/d) and Eenhana (1.5 Ml/d) WWTPs, all of which are surrounded by households (not even 50 m from the plant) and have been in operation for more than one year now. These plants do not emit any obnoxious odours at all and no complaints have ever been received from the inhabitants of the adjacent houses.

Additionally, the Ongos WWTP will be operated by a private operator once completed. This will ensure that tight control can be maintained on such an operator, to adhere to the requirements related to prevention of obnoxious odours and vectors at all times.

3. SUMMARY & CONCLUSION

From the above discussion follows:

- The Ongos WWTP design incorporates equipment to take care of possible obnoxious gases/odours that may be generated at certain unit processes;
- Where such gases are generated, the processes will be enclosed and the gasses will be extracted and then be cleaned (scrubbed) by passing the gas through the Tricking Filter as well;
- An exclusive zone of 150 m will be allowed around the Ongos WWTP, where no houses will be built;
- This zone will be more than sufficient to ensure no obnoxious odours will be generated and/or vectors will be attracted that may become a nuisance to households adjacent to the plant.
- A private operator will be appointed to operate the plant to ensure no obnoxious odours are produced.



AQUARIUS CONSULT CC

Reg. No.: CC/2010/3052

REFERENCES

DWAF, 2010. *Biological Filtration Systems (Trickling Filters)*. Code of Practice, Volume 3. Department of Water Affairs & Forestry. September 2010.

Water Resources Management Act. 2004. Act No 24 of 2004: Government Gazette of the Republic of Namibia, No 3357 of 23 December 2004.

This document prepared by:

Dr. G G Lempert

Date: 3 December 2019



AQUARIUS CONSULT CC

Reg. No.: CC/2010/3052

APPENDIX A: NAMIBIAN WASTEWATER DISCHARGE STANDARDS

Appendix A1. Currently Applicable Standards for Wastewater Discharge

Parameter	Unit	General*	Special*
Colour, odor, taste		No substance that will produce color, odor, taste	No substance that will produce color, odor, taste
Faecal coliforms	per 100 mL	Nil	Nil
Chemical Oxygen Demand (mg/L)	mg/L	75	30
pH		5.5 - 9.5	5.5 - 7.5
Dissolved Oxygen	% satur.	75	75
Temperature	°C	≤ 35	≤ 35
Oxygen Absorbed (N/80/4h)	mg/L	10	5
TDS	mg/L	increase in TDS ≤ 500 over intake water conc.	increase in TDS ≤ 15% over intake water conc.
Ammonia as N	mg/L	10	1
Nitrate/Nitrite as N	mg/L	NS	1.5
Chlorine as Free Chlorine	mg/L	0.1	Nil
Suspended Solids	mg/L	25	10
Electrical Conductivity	mS/m	NS	≤ 70 mS/m above, max 150 mS/m
Soap, oil or grease	mg/L	≤ 2.5	Nil
Arsenic (as As)	mg/L	0.5	0.1
Boron (as B)	mg/L	1	0.5
Cadmium (as Cd)	mg/L	NS	0.05
Hexavalent chromium (as Cr)	mg/L	0.05	NS
Total chromium (as Cr)	mg/L	0.5	0.05
Copper (as Cu)	mg/L	1	0.02
Cyanide (as CN)	mg/L	0.5	0.5
Fluoride (as F)	mg/L	1	1
Iron (as Fe)	mg/L	NS	0.3
Lead (as Pb)	mg/L	1	0.1
Manganese (as Mn)	mg/L	NS	0.1
Ortho-Phosphate (as P)	mg/L	NS	1.0
Total Phosphates (asP)	mg/L	NS	2.0
Sodium (as Na)	mg/L	≤ 50 over intake conc.	≤ 50 over intake water conc.
Sulphides (as S)	mg/L	1	0.05
Zinc (as Zn)	mg/L	5	0.3

* as per Regional Effluent Standard: R553 of 15 April 1962 and amendments (Water Act, 1956)

NS = not specified

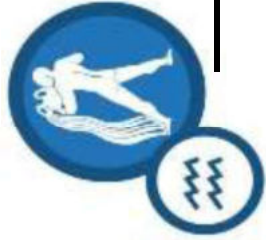

AQUARIUS CONSULT CC

Reg. No.: CC/2010/3052

Appendix A2: Envisaged Future Standards for Wastewater Discharge from Department of Water Affairs

Effluent to be discharged or disposed of in areas with potential for drinking water source contamination; international rivers and dams and in water management and other areas			
DETERMINANTS	UNIT	FORMAT	Special Standard 95 percentile requirements
PHYSICAL REQUIREMENTS			
Temperature	° C		Not more than 10°C higher than the recipient water body
Turbidity	NTU		< 5
pH			6.5-9.5
Colour	mg/litre Pt		< 10
Smell			No offensive smell
Electric conductivity 25 °C	mS/m		< 75 mS/m above the intake potable water quality
Total Dissolved Solids	mg/litre		< 500 mg/litre above the intake potable water quality
Total Suspended Solids	mg/litre		< 40
Dissolved oxygen	% saturation		>75
Radioactivity	units		below ambient water quality of the recipient water body
ORGANIC REQUIREMENTS			
Biological Oxygen Demand	mg/litre	BOD	< 10
Chemical Oxygen Demand	mg/litre	COD	< 55
Detergents (soap)	mg/litre		< 0.2
Fat, oil & grease, individual	mg/litre	FOG	< 1.0
Phenolic compounds	mg/litre	as phenol	< 0.01
Aldehyde	µg/litre		< 50
Adsorbable Organic Halogen	µg/litre	AOX	< 50
INORGANIC MACRO DETERMINANTS			
Ammonia (NH ₄ - N)	mg/litre	N	< 1
Nitrate (NO ₃ - N)	mg/litre	N	< 15
Nitrite (NO ₂ - N)	mg/litre	N	< 2
Total Kjeldahl Nitrogen (TKN)	mg/litre	N	< 5.0
Chloride	mg/litre	Cl	< 40 mg/litre above the intake potable water quality
Sodium	mg/litre	N	< 50 mg/litre above the intake potable water quality
Sulphate	mg/litre	SO ₄	< 20 mg/litre above the intake potable water quality
Sulphide	mg/litre	S	< 0.05
Fluoride	mg/litre	F	1.0
Cyanide (Free)	µg/litre	CN	< 30
Cyanide (recoverable)	µg/litre	CN	< 70
Soluble Ortho phosphate	mg/litre	P	< 1.0
Zinc*	mg/litre	Zn	1

Effluent to be discharged or disposed of in areas with potential for drinking water source contamination; international rivers and dams and in



AQUARIUS CONSULT CC

Reg. No.: CC/2010/3052

water management and other areas				Special Standard	General Standard
DETERMINANTS	UNIT	FORMAT	95 percentile requirements		
INORGANIC MICRO DETERMINANTS					
Aluminium	µg/litre	Al	< 25	< 200	
Antimony	µg/litre	Sb	< 5	< 50	
Arsenic	µg/litre	As	< 50	< 150	
Barium	µg/litre	Ba	< 50	< 200	
Boron	µg/litre	B	< 500	< 1000	
Cadmium*	µg/litre	Cd	< 5	< 50	
Chromium, (hexavalent)	µg/litre	Cr	< 10	< 50	
Chromium, Total*	µg/litre	Cr	< 50	< 1000	
Copper*	µg/litre	Cu	< 500	< 2000	
Iron	µg/litre	Fe	< 200	< 1000	
Lead*	µg/litre	Pb	< 10	< 100	
Manganese	µg/litre	Mn	< 100	< 400	
Mercury*	µg/litre	Hg	< 1	< 2	
Nickel	µg/litre	Ni	< 100	< 300	
Selenium	µg/litre	Se	< 10	< 50	
Strontium*	µg/litre	Sr	< 100	< 100	
Thallium	µg/litre	Tl	< 5	< 10	
Tin*	µg/litre	Sn	< 100	< 400	
Titanium	µg/litre	Ti	< 100	< 300	
Uranium*	µg/litre	U	< 15	< 500	
*Total for Heavy Metals (Sum of Cd,Cr,Cu,Hg,Pb)	µg/litre	Cd,Cr,Cu, Hg & Pb	< 200	< 500	
UNSPECIFIED COMPOUNDS FROM ANTHROPOGENIC ACTIVITIES					
Agricultural chemical compounds	µg/litre			Any in-/organic compound recognized as an agro-chemical is to be avoided or reduced as far as possible. Maximum acceptable contaminant levels will be site specific, dependent on chemical usage and based the water quality of the recipient water body	
Industrial and mining chemical compounds, including unlisted metals and persistent organic pollutants	µg/litre			Any in-/ organic compound recognized as an industrial chemical including unlisted metals is to be avoided or reduced as far as possible. Maximum acceptable contaminant levels will be site specific dependent on chemical usage and based the water quality of the recipient water body	
Endocrine Disruptive Compounds (EDC)	µg/litre			Any chemical compound that is suspected of having endocrine disruptive effects is to be avoided as far as is possible. Maximum acceptable contaminant levels will be site specific dependent on chemical usage and based the water quality of the recipient water body.	
Hydrocarbons (Benzene, Ethyl Benzene, Toluene and Xylene)	µg/litre		Below detection level	Below detection level	
Organo-metallic compounds: methyl mercury, tributyl tin (TBT), etc.	µg/litre		Below detection level	Below detection level	
DISINFECTION					
Residual chlorine	mg/litre		¹ Dependent on recipient water body (at retention time 3 hours)	³ Dependent on recipient water body (at retention time 5 hours)	



AQUARIUS CONSULT CC

Reg. No.: CC/2010/3052

Effluent to be discharged or disposed of in areas with potential for drinking water source contamination; international rivers and dams and in water management and other areas			
		Special Standard	General Standard
DETERMINANTS	UNIT	FORMAT	
BIOLOGICAL REQUIREMENTS (Algae and parasites)			
Further treatment of the effluent dependent on:			
<ol style="list-style-type: none"> 1. the water quality of the recipient water body if any 2. the distance from any point of potable water abstraction 3. an acceptable maximum contaminant level downstream of the point of discharge 4. the exposure to human and animal consumption downstream of the point of discharge 5. any reuse option that may be implemented. 			
MICROBIOLOGY			
Further treatment of the effluent are dependent on:			
<ol style="list-style-type: none"> 1. the water quality of the recipient water body if any 2. the distance from any point of potable water abstraction 3. an acceptable maximum contaminant level downstream of the point of discharge 4. the exposure to human and animal consumption downstream of the point of discharge 5. any water reuse option that may be implemented. 			



AQUARIUS CONSULT CC

Reg. No.: CC/2010/3052

APPENDIX B: PROCESS & INSTRUMENTATION DRAWINGS

Sheet 1:

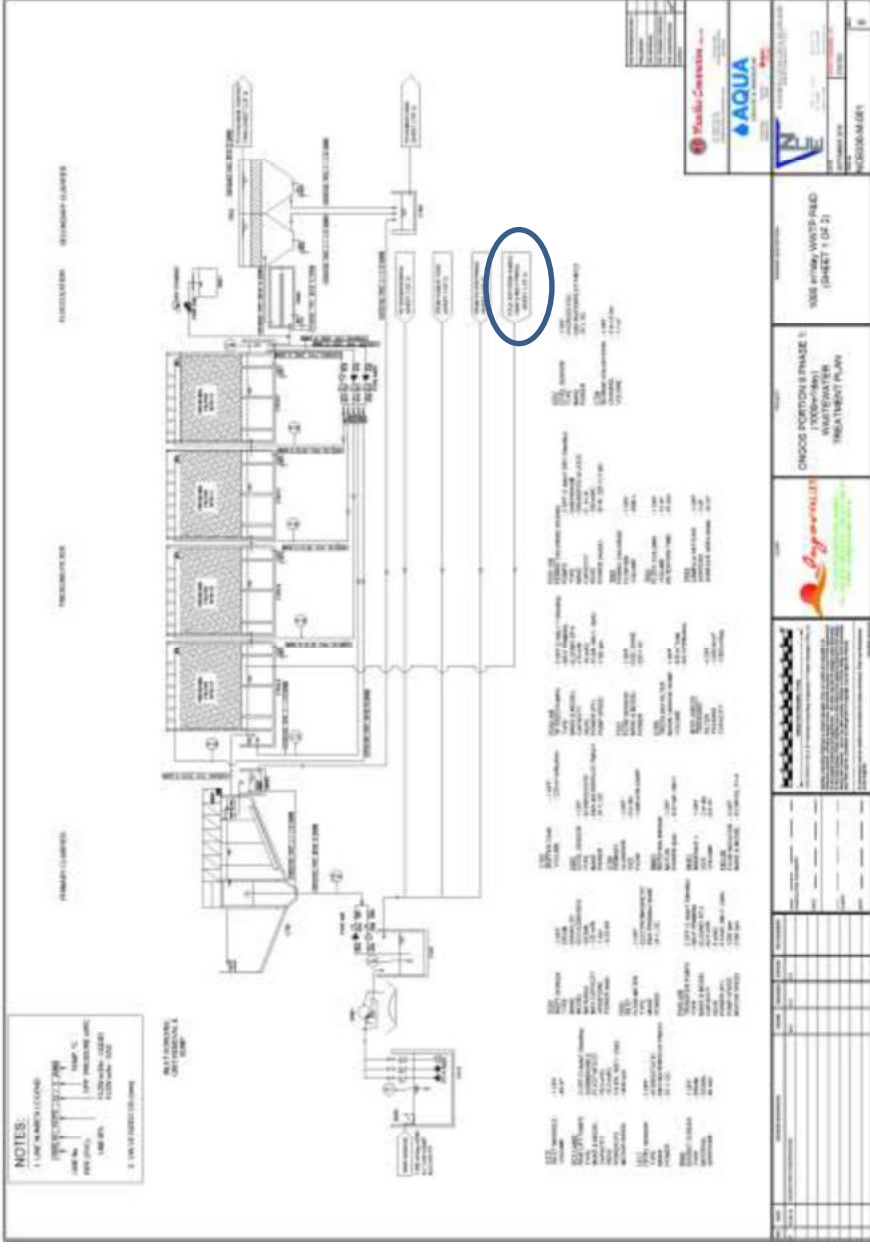

APPENDIX C

Environmental Management Plan (EMP)

For the construction and operational phase



ASSOCIATED TELECOMMUNICATIONS TOWERS FOR ONGOS PORTION 8 & 9 TOWNSHIP DEVELOPMENT ON FARM ONGOS NO.38

February 2024

Compiled by:



Matrix Consulting Services
P.O. Box 25824 Windhoek
Tel: +264-61 224197
Fax: +264-61 212165

Compiled for:

FULLBRIGHT INVESTMENT (PTY) LT
PO Box 20261, Windhoek
Tel:+264 (61) 308106
Fax:+264 (61) 308107

TABLE OF CONTENTS

1.	INTRODUCTION AND BACKGROUND	4
2.	LEGISLATIVE FRAMEWORK	7
3.	ENVIRONMENTAL MANAGEMENT PLAN.....	14
3.1	RESPONSIBILITIES FOR ENVIRONMENTAL MANAGEMENT.....	14
3.2	TRAINING AND INDUCTION	14
3.3	ENVIRONMENTAL INCIDENT REPORTING.....	14
3.4	ENVIRONMENTAL MONITORING.....	14
3.5	EMP ADMINISTRATION	14
3.6	EMP AMENDMENTS	15
3.7	NON COMPLIANCE OF THE EMP	15
3.8	ENVIRONMENTAL REGISTER	15
3.9	ENVIRONMENTAL CONTROL OFFICER	16
3.10	SITE MANAGEMENT	16
3.10.1.1	<i>Access routes and work sites.....</i>	<i>16</i>
3.10.1.2	<i>Fire and safety management</i>	<i>17</i>
3.10.1.3	<i>Staff management.....</i>	<i>17</i>
3.10.1.4	<i>Waste management.....</i>	<i>18</i>
3.10.1.5	<i>Cement and concrete batching.....</i>	<i>18</i>
3.10.1.6	<i>Hydrocarbons management.....</i>	<i>18</i>
3.10.1.7	<i>Information board.....</i>	<i>18</i>
3.10.1.8	<i>Flood management</i>	<i>19</i>
3.10.1.9	<i>Progressive Rehabilitation.....</i>	<i>19</i>
3.10.2	<i>Management of environmental aspects during all phases of the project.....</i>	<i>19</i>
4.	CONCLUSIONS.....	30

GLOSSARY

ENVIRONMENT	an interconnected system of natural and human-made elements such as land, water and air; all living organisms and matter arising from nature, cultural, historical, artistic, economic and social heritage and values.
ENVIRONMENTAL MANAGEMENT	A management process which seeks to ensure, as far as possible, that no avoidable impact is caused to the environment and that when this is unavoidable that the consequences are understood prior to the impact being caused and that the impact is then mitigated as far as possible.
GROUNDWATER	Water located beneath the earth's surface in soil pore spaces and in the fractures of rock formations
HAZARDOUS WASTE	Waste that poses substantial or potential threats to public health or the environment.
MITIGATION	The implementation of practical measures to reduce adverse impacts or enhance beneficial impacts.
NO-GO AREA	Areas where all construction activities and related matters are prohibited.
POLLUTION	Any change in the environment caused by substances, radioactive or other waves; or noise, odours, dust or heat, emitted from any activity, including the storage or treatment of waste or substances, construction and the provision of services, whether engaged in by any person or an organ of state, where that change has an adverse effect on human health or well-being or on the composition, resilience and productivity of natural or managed ecosystems, or on materials useful to people, or will have such an effect in the future.
REHABILITATION	Restoring the disturbed area to more or less the natural set up.
SITE	An area of ground where the Ongos Telecommunications Towers is to be developed.

1. INTRODUCTION and BACKGROUND

The aim of an EMP is to ensure that the proposed telecommunications towers development as part of the Ongos Portion 8 & 9 Township is conducted in an environmentally acceptable and safe manner. This Environmental Management Plan (EMP) serves as a managing tool for all construction and operational activities during the development of telecommunications towers, on Ongos Portion 8 & 9 of Farm Ongos No.38. Figure 1 below shows the location of the proposed waste water treatment plant.



Figure 1: Ongos Portion 8 & 9 Township Telecommunications towers location

The EMP is developed to outline measures to be implemented in order to minimise adverse environmental degradation associated with this development.

The EMP serves as a guiding tool for the contractors and workforce on their roles and responsibilities concerning environmental management on site, and also provides an environmental monitoring framework for all project phases of the development. This environmental management plan aims to take a pro-active route by addressing potential problems before they occur. The EMP acts as a stand-alone document, which can be used during the various phases of the development.

In this report, the Contractor refers to Fullbright Investment (Pty) Ltd and its sub-contractors.

The purpose of the EMP is to:

- ✓ Train employees and contractors with regard to environmental obligations.
- ✓ Promote and encourage good environmental management practices.
- ✓ Outline responsibilities and roles of Fullbright Investment (Pty) Ltd and its contractors in managing the environment.
- ✓ Describe all monitoring procedures required to identify environmental impacts.

- ✓ Minimise disturbance of the natural environment.
- ✓ Develop waste management practices.
- ✓ Prevent all forms of pollution.
- ✓ Protect the natural environment.
- ✓ Prevent soil and water erosion.
- ✓ Comply with all applicable laws, regulations and standards for environmental protection.

Phases covered by the EMP:
Construction Phase
Operational Phase

The construction phase of the telecommunications towers entails:

- ✓ Land clearance
- ✓ Transporting relevant building material and equipment.
- ✓ Installation of associated electrical supply cables.
- ✓ Access road construction

The operational phase will entail:

- ✓ Operation and maintenance of the towers and access road.

1.1 Description of the Telecommunications Towers

The proponent plans on erecting two telecommunications towers within the Ongos Valle Development. The towers will ensure the township has enough capacity for telecommunications infrastructure that will serve the future residents of Ongos Portion 8 & 9 and surrounding areas.

Below is the drawing of the proposed towers:

THIS DRAWING IS THE PROPERTY OF SECTIONAL POLES & MAY NOT BE USED FOR ANY PURPOSE OTHER THAN WHICH IT IS SUPPLIED OR WITHOUT CONSENT FROM THE DRAWER.

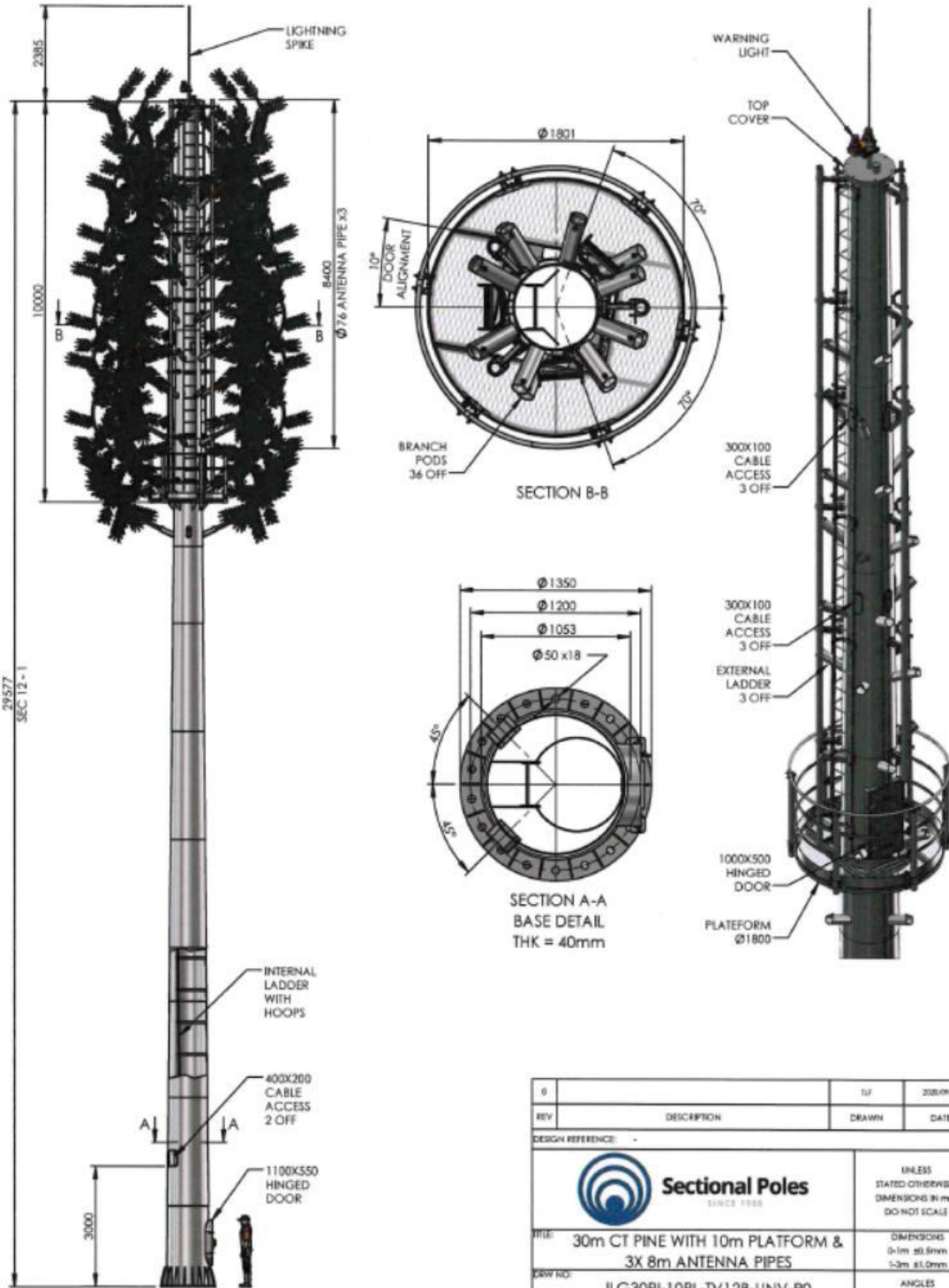

0		TJF	2020/07/14
REV	DESCRIPTION	DRAWN	DATE
DESIGN REFERENCE: -			
 Sectional Poles SINCE 1988		UNLESS STATED OTHERWISE, DIMENSIONS IN mm DO NOT SCALE	
TITLE: 30m CT PINE WITH 10m PLATFORM & 3X 8m ANTENNA PIPES		DIMENSIONS 0-1m ±0.5mm 1-3m ±1.0mm	
DRAW NO: ILG30PI-10PL-TV12B-UNV-RO		ANGLES ±2°	
CLIENT: -		SHEET: 1 OF 1	

2. LEGISLATIVE FRAMEWORK

1.1 National Legislative Requirements

The EIA process is undertaken in terms of Namibia's Environmental Management act no.7 of 2007 and the Environmental Assessment Policy of 1995, which stipulates activities that may have significant impacts on the environment. Listed activities require the authorisation from the Ministry of Environment and Tourism (DEA). Section 32 of the Environmental Management Act requires that an application for an environmental clearance certificate be made for the listed activities. The following environmental legislations are relevant to this project:

➤ *The Namibian Constitution*

The Namibian Constitution has a section on principles of state policy. These principles cannot be enforced by the courts in the same way as other sections of the Constitution. But they are intended to guide the Government in making laws which can be enforced.

The Constitution clearly indicates that the state shall actively promote and maintain the welfare of the people by adopting policies aimed at management of ecosystems, essential ecological processes and biological diversity of Namibia for the benefit of all Namibians, both present and future.

➤ *Communications Act No. 8 of 2009*

All the relevant communications operations' permit and license (broadcasting) should be applied for and obtained from the relevant regulatory authorities. The Proponent should comply with the relevant Sections of Part 5 of the Act. This Part (Special Rights of Carriers). The Sections that will apply to the proposed project are Section 59(1) and (3), 60: Entry upon and construction of lines across any land, 64(1): Fences, 64(2), 66(1): Height or depth of cable and facilities, and 66(2) and 66(3).

Communications Regulatory Authority of Namibia (CRAN), Tel.: +264 61 222 666

➤ *Atomic Energy and Radiation Protection Act o. 5 of 2005*

The Proponent should ensure that they have applied for and obtained all the required licenses for operating the tower in accordance with the Non-ionising Radiation Regulations (2019).

National Radiation Protection Authority, Tel.: 061 203 2417

- ***“Guidelines for Limiting Exposure to Time-Varying Electric, Magnetic, and Electromagnetic Fields (up to 300GHz)” (April 1998 developed by the International Commission on Non-Ionizing Radiation Protection (ICNIRP)).***

To determine the “safe distance” around the site. These provisions justify the need for assessing the impact of electromagnetic radiation from the antennae, on the nearby residents.

National Radiation Protection Authority, Tel.: 061 203 2417

- ***Atmosphere Pollution Prevention Ordinance (1976)***

This Ordinance generally provides for the prevention of the pollution of the atmosphere. Part IV of this ordinance deals with dust control. The Ordinance is clear in requiring that any person carrying out an industrial process which is liable to cause a nuisance to persons residing in the vicinity or to cause dust pollution to the atmosphere, shall take the prescribed steps or, where no steps have been prescribed, to adopt the best practicable means for preventing such dust from becoming dispersed and causing a nuisance.

Line Ministry: Ministry of Environment, Forestry and Tourism

- ***Civil Aviation Act No. 6 of 2016***

The heights of the proposed telecommunication tower might be a threat to the nearest aerodrome site. Therefore, the Proponent should verify these prior to construction with the Namibia Civil Aviation Authority (NCAA). A permit is required from the NCAA to erect the tower. According to NAMCARS and ICAO requirements structures erected within less than 15 km and 8 km distance, respectively require permitting.

Namibia Civil Aviation Authority (NCAA) , +264832352100

- ***Convention on International Civil Aviation, Annex 14***

Annex 14 to the Convention on International Civil Aviation. Chapter 4: Obstacle restrictions and removal. Chapter 6: Visual aids and donating of obstacles

Namibia Civil Aviation Authority (NCAA) , +264832352100

- ***Water Resources Management Act of Namibia (2004)***

This act repealed the existing South African Water Act No.54 of 1956 which was used by Namibia. This Act ensures that Namibia’s water resources are managed, developed, protected, conserved and used in ways which are consistent with fundamental principles depicted in section 3 of this Act. Part IX regulates the control and protection of groundwater resources. Part XI, titled Water Pollution Control, regulates discharge of effluent by permit. Thus developers are required to efficiently plan for sewage disposal.

Line Ministry: Ministry of Agriculture, Water, and Land Reform

➤ **Water Act No.54 of 1956**

This Act provides for Constitutional demands including pollution prevention, ecological and resource conservation and sustainable utilisation. In terms of this Act, all water resources are the property of the State and the EIA process is used as a fundamental management tool.

A water resource includes a watercourse, surface water, estuary or aquifer, and, where relevant, its bed and banks. A watercourse means a river or spring; a natural channel in which water flows regularly or intermittently; a wetland lake or dam, into which or from which water flows; and any collection of water that the Minister may declare to be a watercourse. Permits are required in terms of the Act for the undertaking of the following activities relevant to the proposed project:

- ✓ Discharge of waste or water containing waste into a water resource through a pipe, canal, sewer, sea outfall or other conduit in terms of Section 21 (f); and
- ✓ Disposal of waste in a manner that may detrimentally impact on a water resource in terms of Section 21 (g).

Line Ministry: Ministry of Agriculture, Water, and Land Reform

➤ **The Draft Wetland Policy (1993)**

Requires that any wetlands and its associated hydrological functions form a part, to be managed in such a way that their biodiversity, vital ecological functions and life support systems are protected for the benefit of present and future generations.

Line Ministry: Ministry of Environment, Forestry and Tourism

➤ **Environmental Assessment Policy of Namibia (1995)**

Environmental Assessments (EA's) seek to ensure that the environmental consequences of development projects and policies are considered, understood and incorporated into the planning process, and that the term ENVIRONMENT (in the context of IEM and EA's) is broadly interpreted to include biophysical, social, economic, cultural, historical and political components.

All listed policies, programmes and projects, whether initiated by the government or the private sector, should be subjected to the established EA procedure as set out in Figure 2.

Line Ministry: Ministry of Environment, Forestry and Tourism

➤ **Forestry Act (No.12 of 2001)**

This Act makes provision for the protection various plant species. Harvesting permits are required from the Directorate of Forestry to clear certain protected vegetation species from the site.

Line Ministry: Ministry of Agriculture, Water, and Land Reform

➤ ***Sewerage and Drainage Regulations(amendments) Local authorities act, section 23 (1992).***

The regulations makes provision for proper construction of pipelines in drainage lines. The regulations also stipulate the prevention of pollution and environmental damage caused by improper construction of sewerage and water pipelines in drainage lines.

Line Ministry: Ministry of Regional and Local Government, Housing and Rural Development

➤ ***Soil Conservation Act (No.76 of 1969).***

The Act advocates for the Prevention and combating of soil erosion, conservation, improvement and manner of use of soil and vegetation, and protection of water resources.

➤ ***Environmental Management Act No.7 of 2007***

This Act provides a list of projects requiring an Environmental Assessment. It aims to promote the sustainable management of the environment and the use of natural resources and to provide for a process of assessment and control of activities which may have significant effects on the environment; and to provide for incidental matters.

The Act defines the term “*environment*” as an interconnected system of natural and human-made elements such as land, water and air; all living organisms and matter arising from nature, cultural, historical, artistic, economic and social heritage and values.

The Environmental Management Act has three main purposes:

- (a) to make sure that people consider the impact of activities on the environment carefully and in good time.
- (b) to make sure that all interested or affected people have a chance to participate in environmental assessments
- (c) to make sure that the findings of environmental assessments are considered before any decisions are made about activities which might affect the environment

The development of an telecommunications towers is a ‘*listed activity*’ as per the *List of Activities requiring Environmental Clearance* (Government Notice 29 of 6 February 2012) and accordingly requires an Environmental Impact Assessment (EIA) to be conducted.

Line Ministry: Ministry of Environment and Tourism

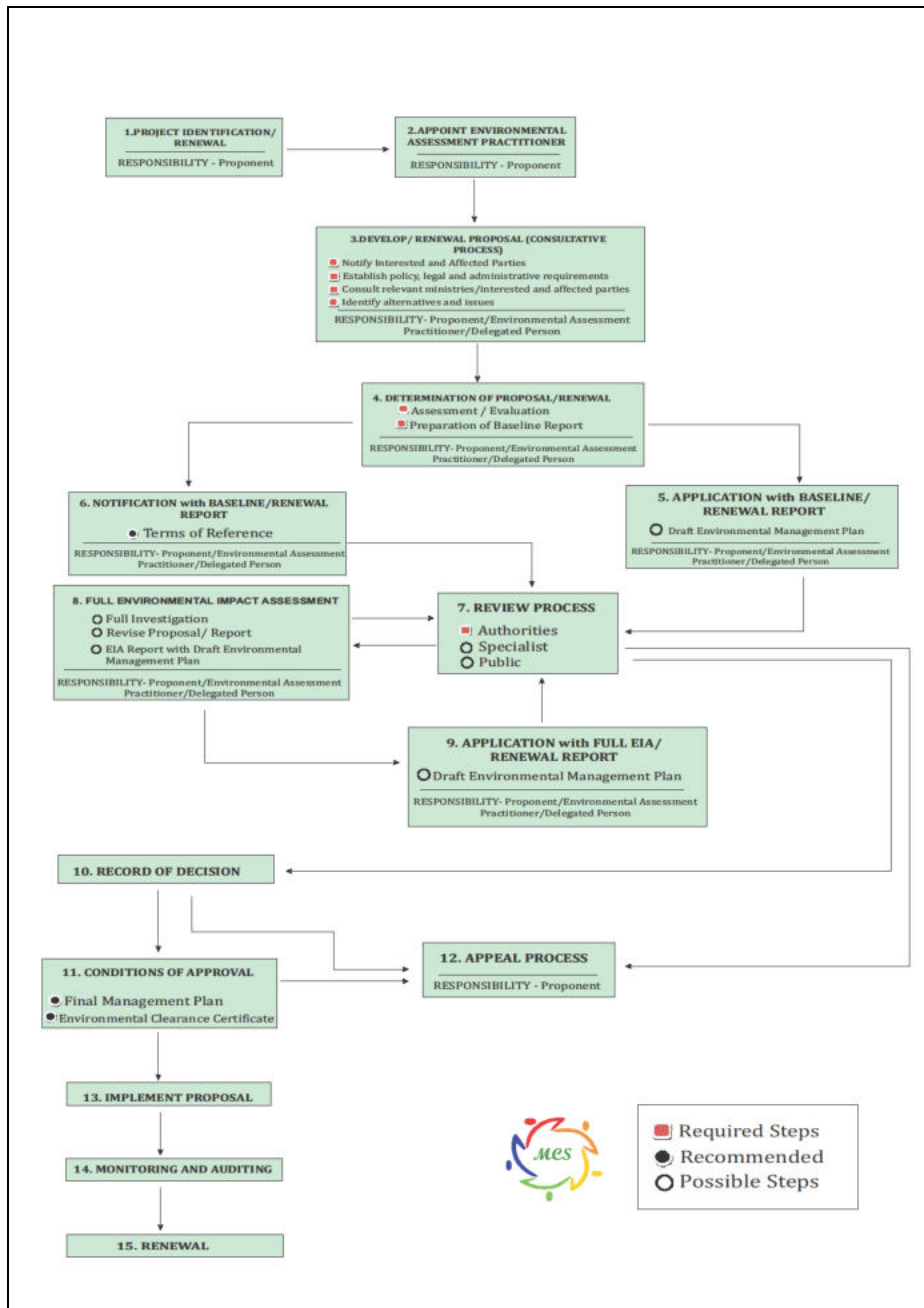

Figure 2. Environmental Assessment Procedure of Namibia (Adapted from the Environmental Assessment Policy of 1995)

➤ **Draft Pollution Control and Waste Management Bill**

The proposed project of Ongos telecommunications towers, applies to Parts 2 and 7 of the Bill.

Part 2 stipulates that no person shall discharge or cause to be discharged any pollutant to the air from a process except under and in accordance with the provisions of an air pollution licence issued under section 23. It further provides for procedures to be followed in licence application, fees to be paid and required terms of conditions for air pollution licences.

Part 7 states that any person who sells, stores, transports or uses any hazardous substances or products containing hazardous substances shall notify the competent

authority, in accordance with sub-section (2), of the presence and quantity of those substances.

➤ ***Hazardous Substances Ordinance No. 14 of 1974***

The Ordinance applies to the manufacture, sale, use, disposal and dumping of hazardous substances, as well as their import and export and is administered by the Minister of Health and Social Welfare. Its primary purpose is to prevent hazardous substances from causing injury, ill-health or the death of human beings.

Line Ministry: Ministry of Health and Social Services

➤ ***Public Health Act 36 of 1919 and Subsequent Amendments***

The Act, with emphasis to Section 119 prohibits the presence of nuisance on any land occupied. The term nuisance for the purpose of this EIA is specifically relevant specified, where relevant in Section 122 as follows:

- ✓ any dwelling or premises which is or are of such construction as to be injurious or dangerous to health or which is or are liable to favour the spread of any infectious disease;
- ✓ any area of land kept or permitted to remain in such a state as to be offensive, or liable to cause any infectious, communicable or preventable disease or injury or danger to health; or
- ✓ any other condition whatever which is offensive, injurious or dangerous to health.

Potential impacts associated with the development of Ongos Portion 8 & 9 project and its associated infrastructure are expected to include dust, air quality impacts, noise nuisance and smoke emissions.

Line Ministry: Ministry of Health and Social Services

➤ ***National Heritage Act (No.76 of 1969).***

The Act calls for the protection and conservation of heritage resources and artefacts. Should any archaeological material, e.g. old weapons, coins, bones found during the construction, work should stop immediately and the National Heritage Council of Namibia must be informed as soon as possible. The Heritage Council will then decide to clear the area or decide to conserve the site or material.

(Tel: 061-244375, National Heritage Council of Namibia)

1.2 International Conventions and Regulations

Article 144 of the Namibian Constitution states that “the general rules of public international law and international agreements binding upon Namibia form part of the law of Namibia.” This means that all the international agreements that Namibia signed become part of the law of our country. These laws and/or agreements are:

- ✓ Convention on Biological Diversity, 1992;
- ✓ United Nations Framework Convention on Climate Change, 1992;
- ✓ Kyoto Protocol on the Framework Convention on Climate Change, 1998;
- ✓ Stockholm Convention of Persistent Organic Pollutants, 2001.

3. ENVIRONMENTAL MANAGEMENT PLAN

3.1 Responsibilities for environmental management

Fullbright Investment (Pty) Ltd will be responsible for environmental control on site during the construction and operational phase. It is very important a pre-work briefing meeting be held at all times to reach an agreement on specific roles of various parties and penalties for non-compliance.

3.2 Training and induction

Fullbright Investment (Pty) Ltd is bound to be responsible for ensuring that environmental awareness education of all employees and contractors is done satisfactorily. Fullbright Investment (Pty) Ltd should ensure that employees and contractors are made aware of the environmental requirements of the project.

The EMP should form part of the Terms of Reference for all contractors, sub-contractors and suppliers. All contractors, sub-contractors and suppliers will have to sign an agreement to assure that they understood the EMP and that they will comply. All senior staff should familiarise themselves with the full contents of the EMP and its implications. Senior staffs (Foreman/Supervisor) are expected to train and assist the rest of the employees on the contents of the EMP.

3.3 Environmental incident reporting

All environmental incidents occurring at the proposed site will be recorded. The incident report will have to include time, date, location, and nature of the incident, extent of the incident, actions taken, and personnel involved.

All complaints received from the neighbouring community should be directed to the Project Manager of Fullbright Investment (Pty) Ltd and channelled to the appointed ECO officer. Fullbright Investment (Pty) Ltd Management should be able to respond to the complainant within a week (even if pending further investigation). It is important that the issues raised are considered and that the complainant feels that their concerns have been addressed to and wherever possible actions taken to address these. All complaints should be entered in the environmental register and all responses and actions taken to address these should be recorded.

3.4 Environmental monitoring

Periodic environmental monitoring must be taken on a regular basis. Monitoring should be done in order to ensure compliance with all aspects of the EMP. Findings should be liaised with to all responsible officers as chain command.

3.5 EMP administration

Copies of this EMP shall be kept at the site office and should be distributed to all senior staff members, including those of the contractors.

3.6 EMP amendments

The EMP amendments can only be made with the approval of the ECO officer and ultimately the DEA. Amendments to the EMP should be liaised to all employees and contractors.

3.7 Non compliance of the EMP

Problems may occur in carrying out mitigation measures or monitoring procedures that could result in non-compliance of the EMP. The responsible personnel should encourage staff to comply with the EMP, and address acts of non-compliance and penalties.

Fullbright Investment (Pty) Ltd is responsible for reporting non-conformance with the EMP, to the ECO officer. The management of Fullbright Investment (Pty) Ltd, in consultation with the ECO officer must, thereafter, undertake the following activities:

- ✓ Investigate and identify the cause of non-conformance.
- ✓ Report matters of non-conformance to Fullbright Investment (Pty) Ltd (depending on the severity of the incident).
- ✓ Implement suitable corrective action as well as prevent recurrence of the incident.
- ✓ Assign responsibility for corrective and preventative action.
- ✓ Any corrective action taken to eliminate the causes of non-conformance shall be appropriate to the magnitude of the problems and commensurate with the environmental impact encountered.

3.8 Environmental Register

An environmental register should be kept on site in which incidents related to actual impacts are recorded. This will include information related to incidents as spillages, dust generation and complaints from adjacent neighbours. It should also contain information relating to actions taken. Any party on site may complete the register, however, it is envisaged that the Technical Manager, the contractor and the ECO officer will be the main contributors, and who will also be the main parties involved in suggesting mitigation measures.

3.9 Environmental Control Officer

The Environmental Control Officer for the site is an independent environmental consultant appointed by Fullbright Investment (Pty) Ltd to monitor and review the on-site environmental management and implementation of this EMP.

Duties of the ECO officer:

- ✓ The identification of potential environmental impacts, prior to the onset of decommissioning. A site visit may also be required prior to site development. This would be carried out in consultation with the Technical Manager.
- ✓ Providing of an environmental register at the site to be filled in by any person reporting an environmental incident, issue or concern and inspected by the ECO officer on a regular basis to check for issues raised and actions taken.
- ✓ Ensuring that the EMP conditions are adhered to at all times and taking action.
- ✓ Ensuring that environmental impacts are kept to a minimum.
- ✓ Reviewing and approving method statements in consultation with the Technical Manager.
- ✓ Reporting to Fullbright Investment (Pty) Ltd and the Technical Manager on a regular basis and advising of any major environmental impacts. Attending the site meetings (when necessary)
- ✓ Inspecting the site and surrounding areas regularly, and monitoring an ongoing environmental awareness program in conjunction with the Technical Manager.
- ✓ Requesting the removal of people and/or equipment not complying with the specifications of EMP.
- ✓ Keeping both a written and photographic record of progress on site from an environmental perspective, and an ad hoc record of all environmental incidents
- ✓ Undertaking continual review of the EMP and submitting a report to the relevant stakeholders.
- ✓ The ECO officer will submit all written instructions and verbal requests to Fullbright Investment (Pty) Ltd via the Technical Manager and Project Engineer.

3.10 Site Management

Areas outside this designated working zone shall be considered “no go” areas. The offloading zones must be clearly demarcated when offloading goods to enhance safety around the project location.

3.10.1.1 Access routes and work sites

During the construction phase, road transport trucks will access the project location via Monte Christo Road and existing municipal roads/tracks. No new tracks/roads shall be established and only existing roads may be used and those that are planned. Work sites shall be clearly demarcated and road signs erected

were needed. The general public should not have unauthorised/uncontrolled access to the project location during this phase.

Vehicle access will be limited to one or two entrances to facilitate control. Access must be of a high standard to prevent unauthorised access from entering the site.

The entrance will be manned during the operation hours; and access routes will be closed to prevent unauthorised entry. A notice board, in two languages, must be erected at the entrance and must state entrance requirements and operating hours of the site, the operator/responsible person and emergency telephone numbers. Suitable signs must also be erected on the approach roads and on-site, to direct drivers and to control speed.

Road access to the working face of the telecommunications towers development must be maintained at all times in a manner suitable to accommodate vehicles normally expected to use the facility. Roads must be regularly graded and wetted to control dust, where necessary.

Furthermore, on-going controls, such as fencing and policing, must be implemented.

3.10.1.2 Fire and safety management

All electrical installations, wiring and systems at the project location, must be approved by a qualified electrician who will issue a Certificate of Compliance.

Proper handling, storage, use and disposal of any hazardous waste (e.g. hydrocarbons, paint, batteries, radioactive waste e.t.c) should be conducted. Hydrocarbons are volatile under certain conditions and their vapours in specific concentrations are flammable. If precautions are not taken to prevent their ignition, fire and subsequent safety risks may arise.

No uncontrolled fire, whether for cooking or any other purpose, is to be made at the project location during both the construction and operation phases by the contractor. The Contractor shall take all reasonable measures and active steps to avoid increasing the risk of fire through activities on site and prevent the accidental occurrence or spread of fire; and shall ensure that there is sufficient fire-fighting equipment on site at all times. This equipment shall include fire extinguishers. The Contractor should be prepared for such events.

3.10.1.3 Staff management

The Contractor must ensure that their employees have suitable personal protective equipment and properly trained in fire fighting and first aid. Training records must be kept for future references.

3.10.1.4 Waste management

Waste will be generated in the form of rubble, cement bags, pipe and electrical wire cuttings. Contaminated soil due to oil leakages, lubricants and grease from the construction equipment and machinery may also be generated during the construction phase.

The oil leakages, lubricants and grease must be addressed. Contaminated soil must be removed and disposed off at the hazardous landfill. The contractor must provide containers on-site, to store any hazardous waste produced. Regular inspection and housekeeping procedure monitoring should be maintained by the contractor.

Waste in the form of solid waste from households, businesses and institutions will also be generated during the operational phase. Waste will be removed and disposed off at a waste disposal site by Fullbright Investment (Pty) Ltd or its contractors.

Fullbright Investment (Pty) Ltd will make provisions for waste skips around these extensions like the rest of the suburbs in Windhoek.

3.10.1.5 Cement and concrete batching

Concrete mixing directly on the ground shall not be allowed and shall take place on an impermeable surface. All run-off from batching areas shall be strictly controlled, and cement contaminated water shall be collected, stored and disposed of at a suitable waste disposal facility.

3.10.1.6 Hydrocarbons management

If any spillage occurs, contaminated soil shall be collected in a holding tray or drum and which will then be disposed at a **hazardous waste disposal site**. Any spillage of more than 200 litres must be reported to the Ministry of Mines and Energy as per the Petroleum Products Act.

The Contractor shall take all reasonable measures to prevent surface or groundwater pollution from the release of oils and fuels.

3.10.1.7 Information board

The Contractor will be responsible for erecting information boards on site. The number and locations of these boards shall be agreed upon by the ECO officer.

The contents of the information board shall be provided by the Technical Manager and will essentially be to advise the public of the construction activity and the prohibition on entering certain areas. The information board shall also provide the contact number of the ECO, to ensure that the public can access

relevant information and lodge any complaints during the construction phase of the telecommunications towers development.

3.10.1.8 Flood management

The telecommunications towers development will be designed in such a way that surface water run-off is well developed. Storm water management of the telecommunications towers development should be a key aspect of flood management at the waste water treatment plant. All culverts should be kept clean to allow storm water to flow freely.

3.10.1.9 Progressive Rehabilitation

Rehabilitation must commence as soon as possible on areas where construction has taken place or no further development is to take place, i.e. on completed excavations, soil/rock cutting hips, slopes etc.

3.10.2 Management of environmental aspects during all phases of the project

Groundwater

Construction phase	
Description	<p>Groundwater quality could be possibly impacted through leachate of oil leakages, diesel, lubricants and grease from the heavy-duty equipment and machinery utilised during construction phase. Care must be taken to avoid contamination of soil and groundwater. Drip trays must be used when removing oil from machinery.</p> <p>Run-off from overflowing onsite temporary sewage systems might transport the effluent to areas where geological structures are present. Inflow into these structures would cause a pollution thread. There are no major faults on the project location.</p> <p>There is a slight potential health impact on groundwater users in the area. Potential impact on the natural environment from the polluted groundwater also exists. In general, impact on groundwater due to the construction of the telecommunications towers development is considered to be minimal through proper management practices.</p>
Proposed Mitigation Measures	<p>Prevent spillages of any chemical or fuel. Use drip trays when doing maintenance on machinery. Maintenance should be done on dedicated areas with linings or concrete floor. No maintenance of machinery may be done at the project location. Implementation of sound and proper management practices.</p>
Proposed Monitoring	<p>Regular visual inspection.</p>
Responsible Party	<p>Fullbright Investment (Pty) Ltd/ Contractors</p>

Operational phase	
Description	<p>Spillages and/or leakages of machinery during operations. Contaminated soil might pose a risk to surface water.</p> <p>Potential impact on the natural environment from possible polluted groundwater also exists. The area is subjected to structures, which might act as preferential pathways for any contaminants entering the saturated zone.</p>
Proposed Mitigation Measures	<p>The risk can be lowered further through the use of suitable and adequate SANS approved piping material; and installation should be done by certified installers/technicians. All surface spillages and leakages must be cleaned up immediately. Proper back-up containment structures should be constructed to avoid any possible leakages.</p> <p>The presence of an emergency response plan and suitable equipment is advised, so as to react to any spillage or leakages properly and efficiently.</p>
Proposed Monitoring	Groundwater monitoring sampling for pollution, (Use data for the upstream and downstream of the trickling filter plant groundwater programme).
Responsible Party	Fullbright Investment (Pty) Ltd

Surface Water

Construction phase	
Description	<p>Contamination of surface water might occur through oil leakages, diesel, lubricants and grease from the heavy-duty equipment and machinery during the construction phase.</p> <p>Surface runoff emanating from overflowing and/or leakages from chemical , temporary sewage storage and reticulation pipeline systems might reach water bodies. Potential Health problems caused by viruses, bacteria and parasites found in the effluent would be the main concern from this pathway.</p> <p>Potential health impact on surface water users and on the natural environment associated with the nearby streams and rivers. Surface runoff from the site is expected in a westerly direction.</p>
Proposed Mitigation Measures	Machinery should not be serviced on site to avoid spills. All spills should be cleaned up as soon as possible. Hydrocarbon/chemical contaminated soil; clothing or equipments should not be washed within 25m of any water body (Aretaragas River and its tributaries).
Proposed Monitoring	Regular visual inspection. Surface water quality monitoring in cases of evident pollution.
Responsible Party	Fullbright Investment (Pty) Ltd /Contractors

Operational phase	
Description	<p>Contaminated soil might pose a risk to surface water. All spills should be cleaned up as soon as possible. An emergency plan should be in place on how to deal with spillages and leakages during this phase.</p> <p>Potential health impact on surface water users and on the natural environment associated with the river channels in the area do exist. This may result in socio-economic impacts on surface water users.</p>
Proposed Mitigation Measures	<p>Drip trays and/or plastic sheeting should be used to contain any leaks emanating from the heavy-duty machinery and fleet. The plant should be equipped with back-up storage capacity to accommodate waste water in cases of breakdown or maintenance.</p> <p>All spills should be cleaned up as soon as possible. The presence of an emergency response plan and suitable equipment is advised, so as to react to any spillage or leakages properly and efficiently.</p>
Proposed Monitoring	Surface water quality monitoring via monitoring boreholes upstream and downstream of the waste water trickling filter plant.
Responsible Party	Fullbright Investment (Pty) Ltd

Air Quality (including Dust Pollution)

Construction phase	
Description	<p>Dust will be generated during the construction and installation of bulk services, and problems thereof are expected to be site specific. Dust is expected to be worse during the winter months when strong winds occur. Release of various particulates from the site during the construction phase and exhaust fumes from vehicles and machinery related to the construction of bulk services are also expected to take place. Dust is regarded as a nuisance as it reduces visibility, affects the human health and retards plant growth.</p>
Proposed Mitigation Measures	<p>It is recommended that regular dust suppression be included in the construction activities, when dust becomes an issue. No unnecessary revving of engines or operation of vehicles is allowed. In general, the waste water treatment plant project is envisaged to have minimal impacts on the surrounding air quality during the construction phase.</p>
Proposed Monitoring	Regular visual inspection.
Responsible Party	Fullbright Investment (Pty) Ltd /Contractors

Operational phase	
Description	Vehicles that will be accessing towers will contribute to the release of hydrocarbon vapours, carbon monoxide and sulphur oxides into the air.
Proposed Mitigation Measures	<p>Vehicle idling time shall be minimised by putting up educative signs.</p> <p>The Proponent should ensure that the waste water treatment machinery and equipment are designed in such a way or contain technologies that can help to control or minimize odour. Some options, such as adding chemicals to the water or using deodorizing misting systems, reportedly work well to a certain extent.</p>
Proposed Monitoring	Regular visual inspection.
Responsible Body	Fullbright Investment (Pty) Ltd

Health and Safety

Construction phase	
Description	<p>Safety issues could arise from the earthmoving equipment and tools that will be used on site during the construction phase. This increases the possibility of injuries and the contractor must ensure that all staff members are made aware of the potential risks of injuries on site. The presence of equipment lying around on site may also encourage criminal activities (theft).</p> <p>No open flames, smoking or any potential sources of ignition should be allowed at the project location. Signs such as 'NO SMOKING' must be prominently displayed in parts where inflammable materials are stored on the premises.</p>
Proposed Mitigation Measures	<p>Equipment and machinery operators should be equipped with ear protection equipment. Operations should be strictly between 07H00 to 19H00. First aid and safety awareness training for contractors.</p> <p>Ensure the general safety and security at all times by providing day and night security guards and adequate lighting within and around the premises. The staff must be properly trained on safety and health issues of the project. Workers should be fully equipped with personal protective equipment gear.</p>
Proposed Monitoring	Safety procedures evaluation. Health and safety incident monitoring.
Responsible Party	Fullbright Investment (Pty) Ltd /Contractors

Operational phase	
Description	<p>A number of health and safety threats exist during operational activities of Ongos Portion 8 & 9 telecommunications towers. Individuals in the community can suffer from noise from maintenance activities around this township and its associated infrastructure. Accidents on roads as a result of increased traffic and deteriorated.</p> <p>The contractors are advised to ensure that proper personal protective gear and first aid kits are available, at all times. Workers should also be properly trained in first aid and safety awareness.</p>
Proposed Mitigation Measures	Operators and maintenance contractors must be properly trained on safety and health issues. Workers should be fully equipped with personal protective equipment gear.
Proposed Monitoring	Regular inspection and incident monitoring report evaluation.
Responsible Body	Fullbright Investment (Pty) Ltd

Noise Impact

Construction phase	
Description	<p>An increase of ambient noise levels at the WWTP site is expected due to the construction activities. Noise pollution due to heavy-duty equipment and machinery will be generated.</p> <p>It is not expected that the noise generated during construction will impact any third parties severely.</p>
Proposed Mitigation Measures	<p>Sensitive construction vehicle drivers and machinery operators to switch off engines of vehicles or machinery not being used. Ensure engines of machinery are fitted with mufflers. Equipment and machinery operators should be equipped with ear protection equipment. Operations should be strictly between 07H00 to 19H00.</p>
Proposed Monitoring	<p>Strict operational times. Regular inspection.</p>
Responsible Party	<p>Fullbright Investment (Pty) Ltd /Contractors</p>

Operational phase	
Description	<p>Noise pollution already exists around the site in the form of noise generated from vehicles frequenting the existing Monte Christo road and other municipal roads and tracks. Noise pollution due to this projecting the operational phase is expected to be mainly from generators or pumps, road maintenance machinery during maintenance.</p>
Proposed Mitigation Measures	<p>Ensure that generator engines are fitted with mufflers. Operators working in close proximity to the generators should be equipped with ear protection equipment, when noise becomes an issue. Observation of on-site noise levels by the Manager or Supervisor .</p>
Proposed Monitoring	<p>Observation of on-site noise levels.</p>
Responsible Body	<p>Fullbright Investment (Pty) Ltd</p>

Waste Generation

Construction phase	
Description	This can be in a form of rubble, cement bags, pipe and electrical wire cuttings. Contaminated soil due to oil leakages, lubricants and grease from the construction equipment and machinery may also be generated during the construction phase.
Proposed Mitigation Measures	<p>The oil leakages, lubricants and grease must be addressed. Contaminated soil must be removed and disposed off at the nearest hazardous landfill. The contractor must provide containers on-site, to store any hazardous waste produced before it is transported to an appropriate hazardous landfill.</p> <p>Ensure that no excavated soil, refuse or building rubble generated on site are not placed, dumped or deposited on adjacent/surrounding properties or land.</p>
Proposed Monitoring	Regular inspection and housekeeping procedure monitoring. Observation of site appearance by the manager.
Responsible Party	Fullbright Investment (Pty) Ltd /Contractors

Operational phase	
Description	Waste in the form of contaminated soil, rubble, biosolids and domestic waste. Littering along access roads may also be produced during the operational phase.
Proposed Mitigation Measures	Waste must be removed and disposed off at a landfill by Fullbright Investment (Pty) Ltd and or its Waste Removal Contractors.
Proposed Monitoring	Regular visual inspection.
Responsible Body	Fullbright Investment (Pty) Ltd

Traffic

Construction phase	
Description	<p>The telecommunications towers activities are expected to have a minor impact on the movement of traffic along the Monte Christo road and township internal roads. No diversion of traffic or closure of roads is expected.</p> <p>Speed limit warning signs must be erected to minimise accidents. Heavy-duty vehicles and machinery must be tagged with reflective signs or tapes to maximise visibility and avoid accidents.</p>
Proposed Mitigation Measures	<p>It is recommended that if the need arises for traffic diversion or road closure, The contractor should liaise with the Fullbright Investment (Pty) Ltd . Speed limit and site warning signs must be erected to minimise accidents. Construction vehicles must be tagged with reflective signs or tapes to maximise visibility of the vehicles and avoid accidents.</p>
Proposed Monitoring	<p>Observations of the traffic flow on Monte Christo road and surrounding municipal roads.</p>
Responsible Party	<p>Fullbright Investment (Pty) Ltd /Contractors</p>

Operational phase	
Description	<p>Traffic around the towers should be monitored, to avoid traffic congestion in the area during maintenance. Speed limits and road signs as set out by Local Traffic Department should be adhered to in order to minimise accidents.</p>
Proposed Mitigation Measures	<p>It is advisable that traffic flow mitigation measures be implement to ease traffic flow around the new towers and its surroundings.</p>
Proposed Monitoring	<p>Observations of the traffic flow on Monte Christo Road and surrounding municipal roads.</p>
Responsible Body	<p>Fullbright Investment (Pty) Ltd</p>

Ecological impacts

Construction phase	
Description	The proposed telecommunications towers development lies in an already disturbed area, which is free of many conservation worthy vegetation and fauna. 100m ² of land will be cleared. However, impacts on fauna and flora are expected to be minimal. Alien invasive species like <i>Prosopis glandulosa</i> and <i>Rhigozium dichotomum</i> should not be conserved and must be cleared and burned in a confined area to avoid further invasion. Vegetation in nearby open spaces may not be disturbed at all.
Proposed Mitigation Measures	Disturbance of areas outside the designated working zone is not allowed.
Proposed Monitoring	Regular site inspection by the Site Manager or Supervisor.
Responsible Party	Fullbright Investment (Pty) Ltd /Contractors

Operational phase	
Description	No impacts are expected from the proposed telecommunications towers in the operational phase. Vegetation in open spaces should not be disturbed or removed during the operational phase. Vegetation in the surrounding open spaces must be conserved or incorporated in future development on open spaces.
Proposed Mitigation Measures	Minimise the area of disturbance by restricting movement to the designated working areas during maintenance.
Proposed Monitoring	Regular site inspection by the Site Manager or Supervisor.
Responsible Body	Fullbright Investment (Pty) Ltd

Erosion and sedimentation

Construction phase	
Description	<p>Vegetation clearance and creation of impermeable surfaces could result in erosion in areas around the telecommunications towers. The clearance of vegetation will further reduce the capacity of the land surface to slow down the flow of surface water, thus decreasing infiltration, and increasing both the quantity and velocity of surface water runoff.</p> <p>The proposed development will increase the amount of impermeable surfaces and therefore decrease the amount of groundwater infiltration. As a result, the amount of storm water during rainfall events could increase.</p>
Proposed Mitigation Measures	Implementation of proper storm water management measures should be done as to prevent negative impacts on the water courses in the area.
Proposed Monitoring	Regular visual site inspection.
Responsible Party	Fullbright Investment (Pty) Ltd /Contractors

Nuisance Pollution

Construction phase	
Description	Aesthetics and inconvenience caused to persons using Monte Christo road and surrounding areas. The construction activities would be visible from those roads.
Proposed Mitigation Measures	The Technical Manager or Supervisor should maintain tidiness on site at all times. Take cognition when parking vehicles and placing equipment.
Proposed Monitoring	Regular visual inspection.
Responsible Party	Fullbright Investment (Pty) Ltd /Contractors

4. CONCLUSIONS

If the above-mentioned management recommendations are properly implemented, it is anticipated that most of the adverse impacts on the environment can be mitigated. An appointed environmental officer/consultant will need to monitor or audit the site throughout construction and operation phase to ensure that the EMP is fully implemented and complied with. The EMP caters for all project phases, but will need to be reviewed during all phases of project, especially when revisions are made to the project development plans.

The Environmental Management Plan should be used as an on-site tool during all phases of the proposed project. Parties responsible for contravention of the EMP should be held responsible for any rehabilitation that may need to be undertaken.

Clearance certificates issued on EIA/EMPs are only valid for 3 years and will need to be reviewed and submitted to the Department of Environmental Affairs again for approval.

Matrix Consulting Services

Chris Ailonga (MSc Env Sci, WITS, MSc Project Management, UP)
Environmental Specialist
February 2024

APPENDIX 1 : Drawings and specifications of telecommunications towers

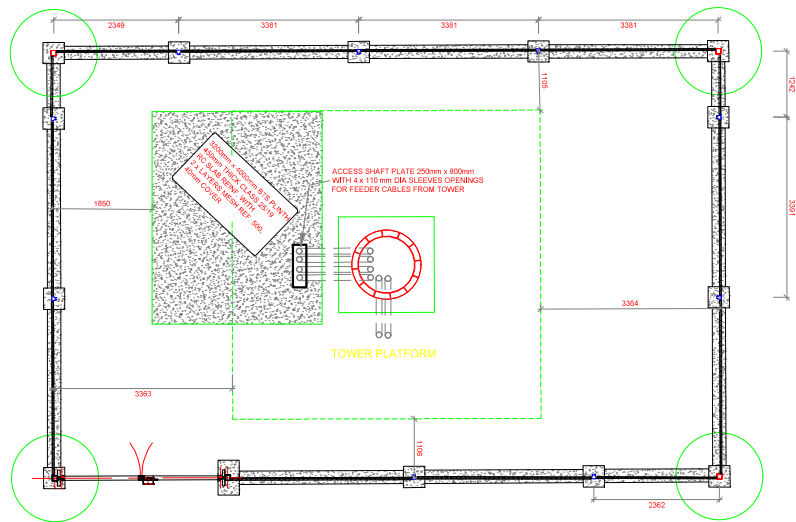

SITE LAYOUT 30m PINE TOWER & BTS CONTAINER
SCALE 1:50

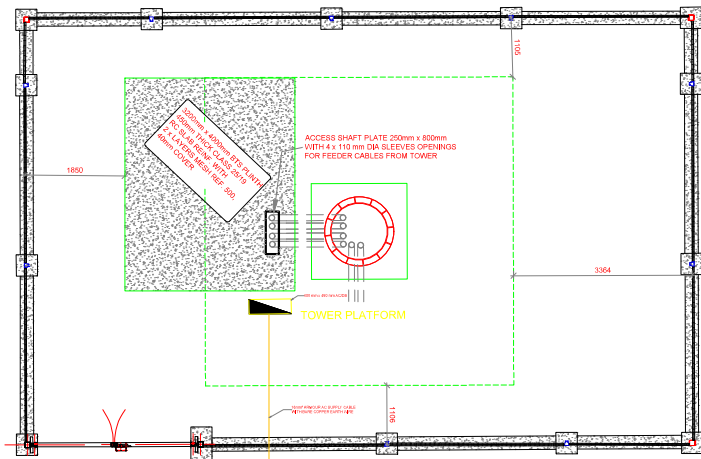

SITE ELECTRICAL LAYOUT
SCALE 1:50

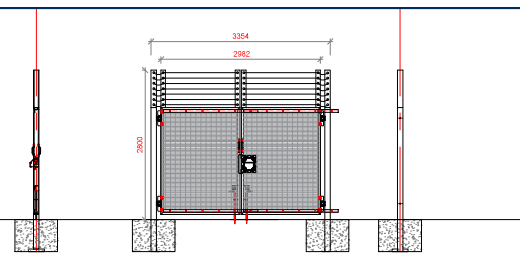

GATE ELEVATION
SCALE 1:25

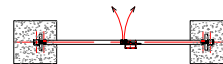

GATE PLAN VIEW
SCALE 1:25

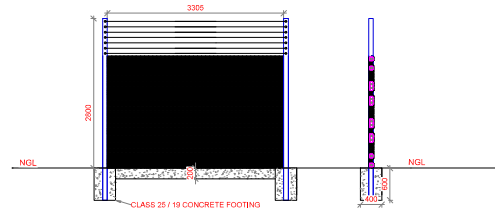

TYPICAL PANEL ELEVATION
SCALE 1:25



FENCE PLAN VIEW
SCALE 1:25

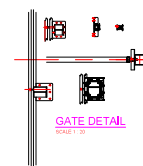

GATE DETAIL
SCALE 1:20

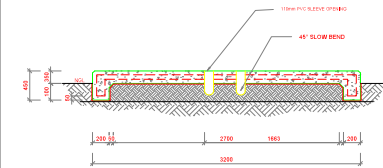

SECTION A
SCALE 1:25

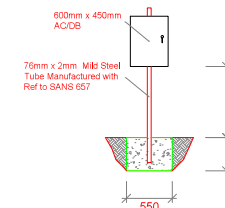

FRONT ELEVATION AC/DB
SCALE 1:25

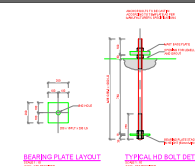

REINFORCEMENT PLATE LAYOUT
SCALE 1:25

TYPICAL 110mm DIA. DETAIL
SCALE 1:25

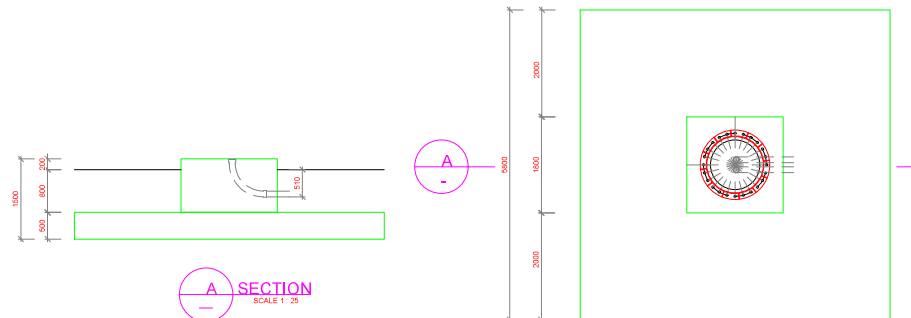

PLAN ON FOUNDATION
SCALE 1:50

Notes:

1. THIS DRAWING IS TO BE READ IN CONJUNCTION WITH ALL RELEVANT POWERCOM PTY LTD BIDDING DOCUMENT TECHNICAL SPECIFICATION.
 2. ALL CO-ORDINATES AND LEVELS TO BE CHECKED BY THE CONTRACTOR
- STRUCTURAL NOTES
1. CONCRETE COVER TO REINFORCEMENT = 50mm UN-DO
 2. ALL CONCRETE WORK TO BE IN ACCORDANCE WITH THE SABS 1008-G UNLESS AMENDED BY THE PROJECT SPECIFICATION
 3. CASHIN ITEMS TO BE SUPPLIED BY TOWER CONTRACTOR UNLESS OTHERWISE NOTED.
 4. THE EXPOSED CORNERS TO HAVE 200mm CHAMFERED UNLESS OTHERWISE STATED.
 5. AFTER INITIAL SET ALL UNSHADERED CONCRETE SHALL BE TREATED WITH AN APPROVED CURING COMPOUND.
 6. A SMOOTH WOOD FLOAT FINISH IS REQUIRED TO ALL EXPOSED HORIZONTAL SURFACES, UNLESS OTHERWISE SPECIFIED.
- HORIZONTAL SURFACES, UNLESS OTHERWISE SPECIFIED
1. WHERE REINBAR IS NOT SPECIFIED, A 250mm THICK PLASTIC SHEET SHALL BE PLACED UNDER ALL CONCRETE
 2. UNLESS OTHERWISE SPECIFIED, THE DEGREE OF ACCURACY FOR ALL WORK SHALL BE DEGREE OF ACCURACY 2 AS SET OUT IN CL. 6.2.2 OF SABS 1008-G (1982), LATEST REVISION
 3. DIMENSIONS MUST NOT BE SCALED OR ASSUMED AND MISSING DIMENSIONS
 4. CONCRETE GRADES SHALL BE: STPB FOOTINGS 25 MPa TOWER BASES 30 MPa; ROOF / FLOOR SLABS 30 MPa
 5. GROUT WITH PROSPECT S-SHAR GROUT OR SIMILAR APPROVED NON-SHRINK, CEMENTITIOUS FLOWABLE GROUT
 6. REBAR SPICE LENGTH TO BE MINIMUM 50 x DI-METER OF BAR

REV.	DESCRIPTION:	BY:	DATE:
------	--------------	-----	-------



EMPLOYER: POWERCOM PTY LTD
NO 4 JULIUS IVERERE STREET
WINDHOEK
SOUTHERN INDUSTRIAL

DEPARTMENT: PROJECTS

DRAWN:	CHECKED:	DATE:	REVISION:
RK	MI	23/08/2023	1

PROJECT NAME: 30m Pine TOWER

DRAWING TITLE: SITE LAYOUT

SCALE:	SHEET SIZE:	SHEET NO.:
1:50, 1:250	A1	1 of 1

PROJECT NO: W/PC-10

STATUS: CONSTRUCTION

DRAWING NO: PC10-001

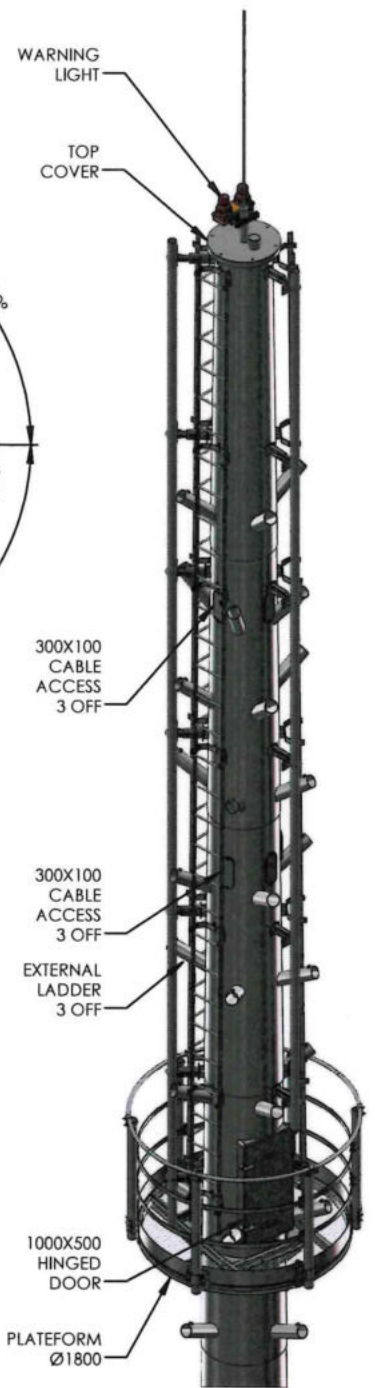
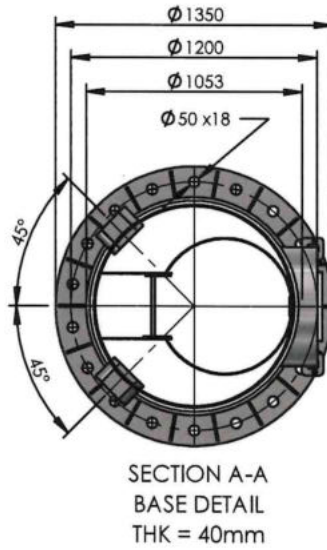
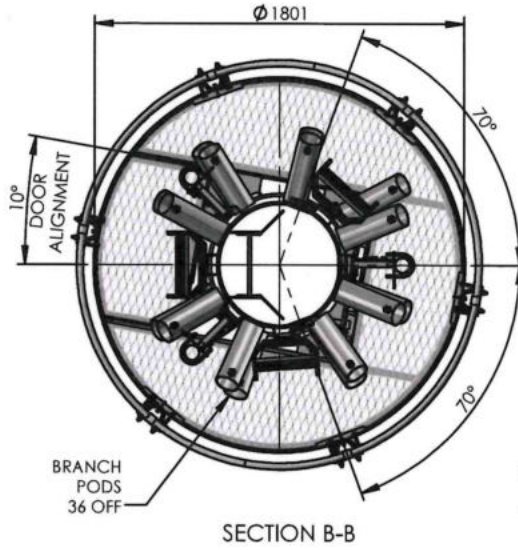
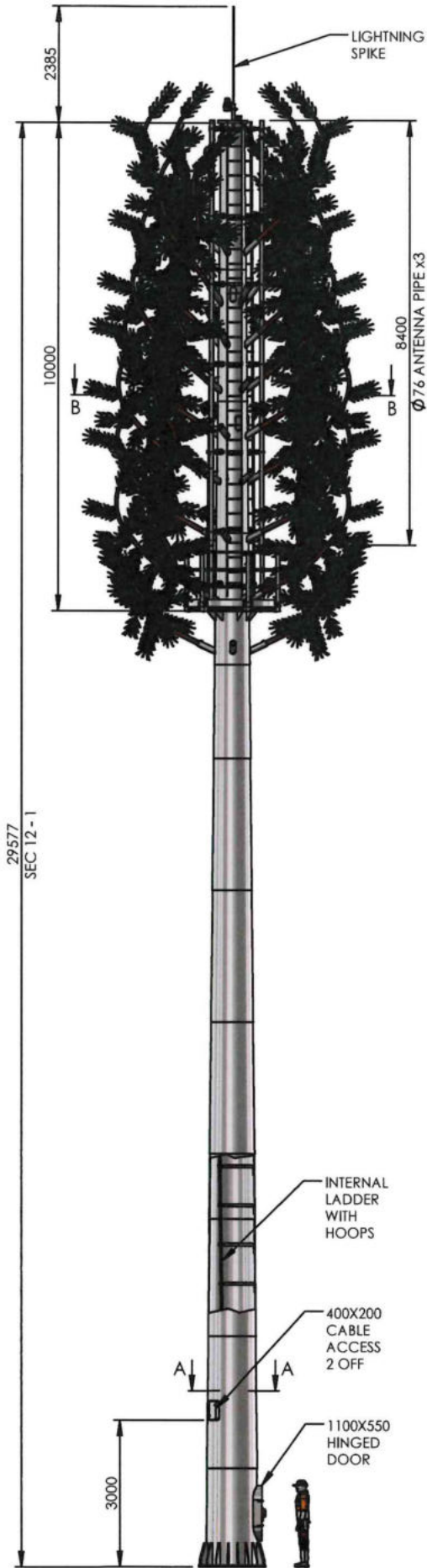

0		T1F	2020/09/14
REV	DESCRIPTION	DRAWN	DATE
DESIGN REFERENCE: -			
 Sectional Poles SINCE 1966		UNLESS STATED OTHERWISE, DIMENSIONS IN mm DO NOT SCALE	
TITLE: 30m CT PINE WITH 10m PLATFORM & 3X 8m ANTENNA PIPES		DIMENSIONS 0-1m ±0.5mm 1-3m ±1.0mm	
DRW NO: ILG30PI-10PL-TV12B-UNV-R0		ANGLES ±2°	
CLIENT:		SHEET: 1 OF 1	



Sectional Poles

SINCE 1966

HEAD OFFICE:
 TEL: +2712 348 8660
 FAX: +2712 348 9195
 334 Glenwood Road
 Lynnwood Park
 Pretoria
 PO Box 17028
 Groenkloof, 0027
 Webpage: www.sectionalpoles.co.za
 Email: sales@sectionalpoles.co.za

Design according to SANS 10225:2012
 Ultimate Limit State Design

DESIGN REPORT

Client / Project Name: **Powercom** Ref No.: 21-11-24-09:16:36

Cutting List: 35m TV: Sect 1-12

Mast Description: **30m, Tree Mast (TV)**

2	1000m	40.0m/s	0.0m	0.85	355MPa
Site Terrain Category	Site Altitude	Regional Wind speed	Artificial Base Height	Importance Factor	Steel Yield Stress

Mast Loading:

Description of Concentrated Loadings	Aw (m ²)	Cr	Installation Height from Top (m)	Mass (kg)
Platform	0.5	1.56	10	150

Description of Distributed Loadings	Aw (m ² /m)	Cr	Installation Height from Top (m)		Mass (kg/m)
			Start	End	
Top Ext. Ladders	0.0875	1.8	0	10.00	30
Int. Ladder	0.085	0	10	30.00	14
Antenna Mounting Pipes	0.228	0	0	8.00	16.26
14Sq Antenna Loading	1.4	0.6	0	10.00	70
Branch Loading	2.5	0.84	0	10.90	100

Applied Bending Moment: No Applied Bending Moment

Mast Geometry:

Top Diameter	0.483m	The mast cross-section is: Round		Mast Actual Height	29.6m
Bottom Diameter	1.051m	Top Section No.	1	Bottom Section No.	12
		Gust Loading Factor	2.915		

Bending Moments & Forces:

	Actual (SLS)	Actual (ULS)	Allowable	(Actual/Allowable)
Max Actual-/Allow Bending Moment at 18.4m	333.0kNm	681.5kNm	853.7kNm	79.82%
Bending Moment at Base	655.7kNm	1341.7kNm	1754.5kNm	76.47%
Total Shear Force	30.6kN	62.6kN		

Deflections:

	Serviceability-	Ultimate Limit State
Maximum Angle	1.1°	2.3°
Maximum Displacement	0.34m	0.70m

Masses:

Shaft	Platform & Extras	Ladder	Hold-down Bolts	Base Flange	Total Mass	Accessories
4572.2kg	280.1kg	580.0kg	262.0kg	176.0kg	5870.3kg	1790.0kg

Hold-down Bolts:

Minimum Tensile Strength: 550MPa	18 x M39 Uniformly Arranged on PCD:1200mm		
Tension Force on Hold-down Bolts: (208mm Centre to Centre)	Actual	Allowable	(Actual/Allow)
	252.2kN	359.6kN	70.1%

Base Flange:

1053mm	1200mm	1350mm	40mm
ID	PCD	OD	t

Benjy Schraader 2021-11-24
 Originator Date Signature of Pr. Eng Pr. Number Date



SECTIONAL POLES

Drawing Number



FD-BS-21-11-24-09-16-36.pdf

Mast/Structure Description: 30m Tree Mast(TV), 14Sq, Cat2, Hasl:1000m

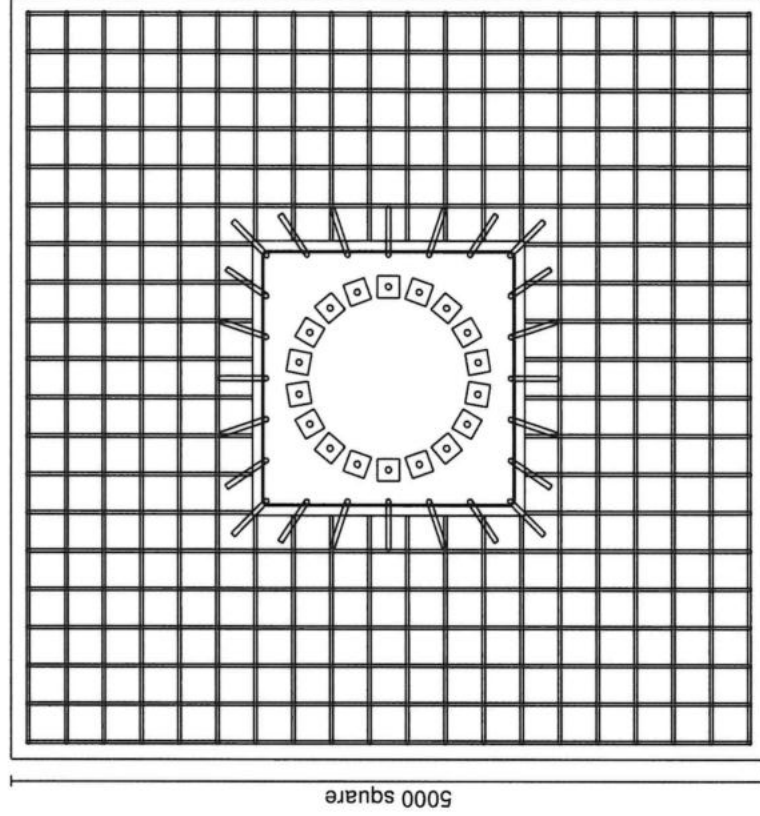
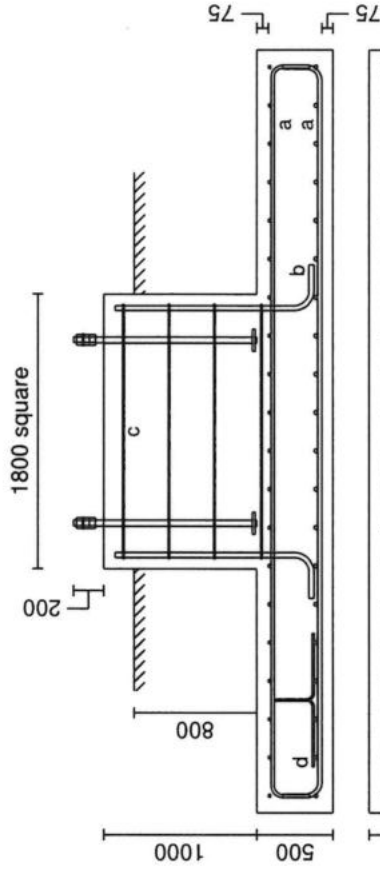
Bending Moment (ULS): 1341.7 kNm
 Shear Force (ULS): 62.6 kN
 Structure Mass: 7660.3 kg
 Applied vertical force (ULS): 0.0 kN
 Required Soil Pressure: 143.2 kPa
 Concrete Volume: 15.7 m³
Concrete Strength: 30 MPa - NOTE!
 Reinforcement Mass: 1594.2 kg
 Reinforcement Strength: 450 MPa
 Excavation Volume: 32.5 m³
 Backfill Volume: 17.4 m³

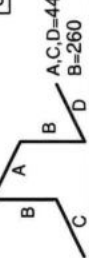

Shape codes and dimensions of steel reinforcement according to SABS 82:

Ref.	Quantity		Diameter		Full Length		Diagram	Shape Code
	Top	Bottom	Top	Bottom	Top	Bottom		
a	40	40	20	25	5205	5180		38
b	24		32		1520			37
c	4		10		6694			60
d	23		12		1736			83

Notes:

1. Foundation Bolts per Plynth: 18x M39Plate, 1200 mm PCD , UTS 550 MPa min, fixing templates to be placed at top and bottom of bolts before casting
2. Positioning of stools (Ref. d) to be determined on site to provide sufficient support between Top and Bottom bars (Ref. a)
3. Bottom and top reinforcement mats each consist of 20 x 20 bars at 251 mm spacing

APPENDIX D

CURRICULUM VITAE

Chris Elungi AILONGA

NAME OF CONSULTANT : **Chris E. Ailonga**
DATE OF BIRTH : **17/12/1983**
NATIONALITY : **Namibian**
MEMBERSHIP IN PROFESSIONAL BODIES & ASSOCIATION : **EAPAN (35) (2018- President)**

KEY QUALIFICATIONS

Chris is an EIA Lead Practitioner and a Director at Matrix Consulting Services, with variable experience in Project Management, Risk Management, Environmental and socio-economic impact assessments, environmental management plans, mine environmental management, pollution investigations, environmental awareness training, public participation, environmental auditing, health and safety plans, rehabilitation, mine tailings management, environmental management systems (ISO 14001:2015), Occupational health and safety management systems (ISO 45001:2018), urban planning and related work.

He has been involved in various mining, mineral and water exploration projects, petroleum industry, residential and commercial developments, waste disposal, hospitality projects, waste water treatment, chemical handling facility projects, town and regional planning projects, agriculture, infrastructure, waste reclamation projects and food processing.

EDUCATION & TRAINING

2020 : **MSc Project Management**
University of Pretoria

2016 : **Post Graduate Diploma in Planning**
University of Witwatersrand

2011 : **IRCA ISO14001 Lead Auditor Certificate**
TUV Rheinland

2010 : **MSc Environmental Science**
University of Witwatersrand

2007 : **Cleaner Production Best Practice in the Mining Industry, NQF Level 5**
University of Witwatersrand

2005 : **4 Yr-BSc Environmental Biology and Microbiology**
University of Namibia

EMPLOYMENT RECORD

Feb 2012 - Till now : **Matrix Consulting Services**
Principal Project Manager- Environmental & Urban Planning
Managing the Environmental & Urban planning Department, project management, budgeting and complete preparation of environmental and Social impact assessments, Environmental Compliance Audits, Pollution Investigations, health and safety plans, environmental management plans and related work, of which most were related to mining & exploration projects, fuel retail and consumer facilities, roads, bulk water supply pipelines, aquifer recharge projects, township developments, town and regional planning, educational facilities medical waste treatment facilities, agricultural projects, chemical warehouses and hotels. Pollution investigations, environmental monitoring and reporting.

- June 2011 –Feb 2012** : ***Langer Heinrich Uranium Mine***
Environmental Coordinator
 Coordinating all environmental management activities at the mine. Managing the environmental team, and supervising the water monitoring team and waste management contractors. Managing the ISO14001 environmental management system and conducting periodic audits to ensure compliance. Ensuring EMP compliance and implementing mitigating measures. Environmental awareness training of all mine staff and contractors.
- Jan 2010 –June 2011** : ***Consulting Services Africa***
Project Manager: Environmental Impact Assessments
 Project management and complete preparation of environmental impact assessments, environmental management plans and related work, of which were mostly related to infrastructure (e.g roads), agriculture (e.g. fertilisers and quarantine camps)
- 2009** : ***Geo Pollution Technologies***
Environmental Consultant
 Project management and preparation of numerous environmental impact assessments, of which a large number were related to water resources, mining, petroleum and hydrogeology.
- 2008** : ***ALS Laboratory Group (Trekkoptje Uranium Mine)***
Senior Chemical Laboratory Scientist
 Supervision of the chemical laboratory team at the mine. Quality assurance of the samples and chemical analysis of the results. Managing and procurement of the laboratory supplies.
- 2007** : ***NAMDEB Mine***
Environmentalist
 Coordinating all environmental management activities at the Orange River Mines. Conducting environmental audits and compliance to the ISO14001 environmental management system. Ensuring EMP compliance and implementing mitigating measures. Water quality and pollution investigations at the mine.
- 2006** ***SANTED***
Graduate Researcher
Biodiversity Studies -Powerlines way leave

PROJECT EXPERIENCE

Environmental Impact Assessments (EIAs) –all including EMPs and Public Participation	
PROJECT	Client
Environmental and socio-economic Impact assessment, The proposed Venus Ext 1-4 Township, Windhoek.	City of Windhoek
Environmental and socio-economic Impact assessment, The proposed Khomasdal Ext 17-18 Township, Windhoek.	City of Windhoek
Environmental and socio-economic Impact assessment, The proposed Havana Relocation Township, Windhoek.	Ongos Valley Development
Environmental and socio-economic Impact assessment, The proposed monte christo decongestion & road upgrading: ongos to b1 interchange, Windhoek.	City of Windhoek
Renewal of environmental clearance certificate for the continued operation of the existing engen fuel storage depot in keetmanshoop.	Engen Namibia (PTY) LTD
Project management, engineering design, fuel retail application, EIA for the proposed new fuel retail facility in kalkrand	Mensah Service Station CC
Project management, engineering design, fuel retail application, EIA for the proposed olive oil plant at Brakwater.	Shetu Trading Development (Pty) Ltd
Environmental Consultancy for the upgrade of 6 AGRA-Vivo Energy sites	Vivo Energy
Continued operation of the existing seaflower fish processing facility (factory), Luderitz, //kharas region	Seaflower Group (Pty) Ltd
Proposed New Fuel Retail Facility In Swakopmund (Pitstop Fuel Centre)	Sky-Way Investments CC
Provision of professional technical support services for assessment and compilation of a report on the status quo of properties of NTA.	Namibia Training Authority
Project management, engineering design, fuel retail application, EIA for the proposed new fuel retail facility in Okondjatu	Earth Ethicks Construction cc
Environmental and socio-economic Impact assessment, the existing waste disposal site and the sand mining activities in Henties Bay.	Henties Bay Municipality
Mashare Agricultural Development institute, Development of Health and Safety Plans, and the implementation of a Health and Safety program, and training.	Ministry of Agriculture, Water and Forestry: (Mashare Agricultural Development Institute)
Environmental and socio-economic Impact assessment, the proposed EXT 5, Aroab.	Aroab Village Council
Environmental and socio-economic Impact assessment, the proposed Asparagus Processing Plant in Oshifo, Ruacana.	Otjimbele Agriculture (Pty) Ltd
Environmental and socio-economic Impact assessment, the proposed	Unistrat Properties Investment

CURRICULUM VITAE

Chris Elungi AILONGA

Otjiwarongo EXT 12.	
Environmental and socio-economic Impact assessment, the proposed infrastructure improvements for 14 schools around Namibia, AfDB funded projects.	Ministry of Education, Arts and Culture
Environmental and socio-economic Impact assessment, the proposed UNAM Small Animals Teaching Hospital, School Veterinary Science AfDB funded projects.	UNAM
Environmental and socio-economic Impact assessment, the proposed Keetmanshoop Vocation Training Centre, AfDB funded projects.	Namibia Training Authority
Environmental and socio-economic Impact assessment, the proposed Zambezi Vocation Training Centre, AfDB funded projects.	Namibia Training Authority
Environmental and socio-economic Impact assessment, the proposed Hardap Vocation Training Centre, AfDB funded projects.	Namibia Training Authority
Environmental and socio-economic Impact assessment, the proposed Seeis Piggery.	M & K Trading cc
Environmental and socio-economic Impact assessment, the proposed Ondangwa Ext 31-34 township development.	Ondangwa Town Council
Hydrogeology and ecological specialist studies for Grootfontein ext 6 EIA	Ritta Khiba Town Planning Consultants cc
Environmental and socio-economic Impact assessment, the proposed Kalkfeld township development.	Otjozondjupa Regional Council
Environmental and socio-economic Impact assessment, the proposed Bitumen Manufacturing Plant	Project 7 Trading cc
Environmental Conditions Assessment (Environmental Due Diligence) and Health and Safety Plan, Total Karasburg Service Station in Karasburg (Including Tank pit screening, Soil sampling and Soil vapour survey).	Total Namibia (Pty) Ltd
Environmental Conditions Assessment (Environmental Due Diligence), Hakahana Service Station in Windhoek (Including Soil sampling and Soil vapour survey).	Vivo Energy Namibia Ltd
Environmental Conditions Assessment (Environmental Due Diligence) and Health and Safety Plan, Puma Tren Tyre Service Station in Otjiwarongo (Including Soil sampling and Soil vapour survey).	
Site Closure, Environmental Conditions Assessment (Environmental Due Diligence), Supa Quick Service Station in Windhoek (Including Tank pit screening, Health and Safety Plan, Soil sampling and Soil vapour survey).	Total Namibia (Pty) Ltd
Environmental and Safety Conditions Assessment (Environmental Due Diligence), Eastgate Service Station at Buitepos (Including Tank pit screening, Soil sampling and Soil vapour survey).	Total Namibia (Pty) Ltd
Environmental and socio-economic Impact assessment, the proposed Ondangwa extension 31-34 township development.	Ondangwa Town Council

CURRICULUM VITAE

Chris Elungi AILONGA

Environmental and socio-economic Impact assessment, the proposed Oshikuku Cultural Heritage Centre.	Oshikuku Town Council
Environmental and socio-economic Impact assessment, the proposed Matutura Mall development.	Swakopmund Municipality
Environmental and socio-economic Impact assessment, Environmental Compliance Audit, the proposed Oranjemund Landfill development.	NAMDEB
Environmental Fatal Flaws for 4 Solar PV Plants, Omburu, Auas, Koekerboom and Otjikoto	Nampower / Mott Macdonald
Environmental and socio-economic Impact assessment, Environmental Compliance Audit the proposed Epukiro extension 1,2,3 and Proper township development.	Omaheke Regional Council
Environmental and socio-economic Impact assessment, the proposed Epukiro Landfill development.	Omaheke Regional Council
Environmental and socio-economic Impact assessment, Epukiro Oxidation Ponds	Omaheke Regional Council
Environmental Management Plan, Epukiro Cemetery	Omaheke Regional Council
Environmental and socio-economic Impact assessment, Environmental Compliance Audit, The proposed Solar Plants in Otavi, Tsumeb and Grootfontein.	Metdecci Energy Investment (Pty) Ltd
Environmental and socio-economic Impact assessment, The proposed new Katima Mulilo Puma Energy Fuel Depot, Zambezi Region.	Tidal Wave Pty Ltd
Environmental and socio-economic Impact assessment, The proposed new Bukalo Academy and University Campus Development, Zambezi Region.	First Capital Treasury Solutions (Pty) Ltd
Environmental and socio-economic Impact assessment, The proposed new Oshakati Multi-Purpose Centre Development.	Oshakati Town Council (Aveshe Consultancy)
Environmental Impact Assessment and Environmental Management Plans, Environmental Compliance Audit The proposed new townships (Rentes Township Development EXT 3 and 7).	Otavi Town Council
Environmental Management Plan, The proposed Wernhill Phase 4 Development.	Olthaver and List (Pty) Ltd
Environmental and socio-economic Impact assessment, The proposed new Kleine Reho Township Development.	P & D Bricks cc
Environmental and socio-economic Impact assessment, The proposed new Rehoboth Industrial Township Development.	Rehoboth Town Council
Environmental and socio-economic Impact assessment, Environmental Compliance Audit ,The proposed new Otjinene Phase 6 Township Development.	Omaheke Regional Council
Environmental and socio-economic Impact assessment, The proposed new Rentes Township Development. (400 units)	Otavi Town Council

CURRICULUM VITAE

Chris Elungi AILONGA

Environmental and socio-economic Impact assessment, The proposed new Township Development (Block A & B).	Bethanie Village Council
Environmental and socio-economic Impact assessment, Environmental Compliance Audit, The proposed Ongos Portion 8 & 9 Township Development.	Full Bright Investments (Pty) Ltd
Environmental and socio-economic Impact assessment, The proposed Muzine Mall Development in Gobabis.	Muzine Group (Pty) Ltd
Environmental and socio-economic Impact assessment, Environmental Compliance Audit , The proposed 5MW Solar Plant in Karibib.	Metdecci Energy Investment (Pty) Ltd
Environmental and socio-economic Impact assessment, The proposed Ongos Portion 3 and Monte Christo Township Development.	NHE
Environmental and socio-economic Impact assessment, The proposed new Nakayale Vocational Training Centre Development.	NTA
Environmental and socio-economic Impact assessment, The proposed Kobra Service Station in Oshikuku.	Namibia Funeral Services
Environmental and socio-economic Impact assessment, The proposed new Township development	Kalkrand Village Council
Environmental and socio-economic Impact assessment, Environmental Compliance Audit, The proposed Xpress Service Centre in Walvis Bay.	Walvis Bay Xpress Service Centre cc
Environmental and socio-economic Impact assessment, The proposed Onathing Service Station in Onathing.	ASM Investment cc
Environmental and socio-economic Impact assessment, The proposed Onathing Service Station in Onathing.	Divundu Service Station cc
Environmental and socio-economic Impact assessment, The proposed Otjinene Service Station in Otjinene.	Otjinene Service Station cc
Environmental and socio-economic Impact assessment, The proposed Olundjinda Mining exploration (EPL 4216), Namib Naukluft, Karas region.	Olundjinda Mining (Pty) Ltd
Environmental and socio-economic Impact assessment, The proposed new Otavi Industrial Park development	Galaxy Industries (Pty) Ltd
Environmental and socio-economic Impact assessment, The proposed 1MW Solar Plant in Khorixas.	Welwitschia Solar
Environmental Management Plans, Environmental Compliance Audit, The existing solid waste disposal sites (9), Windhoek.	City of Windhoek
Environmental and socio-economic Impact assessment, The proposed Oasis fuel retail facility, Usakos.	Oasis Service Centre
Environmental and socio-economic Impact assessment, The proposed HALOID Industrial Township, Windhoek.	City of Windhoek
Environmental Impact Assessment and Environmental Management Plans,	CENORED

CURRICULUM VITAE

Chris Elungi AILONGA

The proposed 40Km new dedicated Otavi Power supply 33Kv.	
Environmental Impact Assessment and Environmental Management Plans, The proposed new townships development Choto Portion (A-G).	Katima Mulilo Town Council
Environmental Impact Assessment and Environmental Management Plans, Environmental Compliance Audit The proposed exploration phase of EPL 4953.	The Kongom Trading cc
Environmental Impact Assessment and Environmental Management Plans, The proposed new Otavi Service Station.	Engen South Africa
Environmental Impact Assessment and Environmental Management Plans, The proposed new townships (Khoab EXT 4 & 5 and Otavi EXT 5 & 6).	Otavi Town Council
Environmental Impact Assessment and Environmental Management Plans, The proposed new UNAM southern campus.	UNAM
Environmental Impact Assessment and Environmental Management Plans, The proposed new Otavi Landfill Otjozondjupa Region.	Otavi Town Council
Environmental Management Plans, The proposed Hobas and Naukluft Camp Upgrade, Karas Region.	Namibia Wildlife Resorts
Environmental and socio-economic Impact assessment, The proposed Okahao-Iitapa pipeline (43Km).	Min of Agriculture, Water and Forestry
Environmental and socio-economic Impact assessment, Environmental Compliance Audit, The proposed Windhoek Aquifer Project, Windhoek.	City of Windhoek
Environmental and socio-economic Impact assessment, The proposed Otavi Poultry Project.	Fresh Farm Chicken cc
Environmental and socio-economic Impact assessment, The proposed Otjomuise Ext 5 Township, Windhoek.	Ino Investment (Pty) Ltd/ City of Windhoek PPP
Environmental and socio-economic Impact assessment, The proposed Rocky Crest Ext 4-9 Township, Windhoek.	City of Windhoek
Environmental and socio-economic Impact assessment, Environmental Compliance Audit , The proposed Coal Bed Methane exploration drilling at Machita Village, Caprivi Region.	CSG Energy Namibia (Pty) Ltd
Environmental and socio-economic Impact assessment, The proposed Landfill Gas Extraction from Kupferberg Landfill, Windhoek.	City of Windhoek
Environmental and socio-economic Impact assessment, Environmental Compliance Audit, The proposed Coal Bed Methane exploration drilling in the Huab Block, Kunene Region.	CSG Energy Namibia (Pty) Ltd
Environmental Management Plans, The proposed Ruacana Waste Disposal Site.	Ruacana Town Council
Environmental and socio-economic Impact assessment, The proposed Chemical warehouse in Windhoek.	Salute Trading (Pty) Ltd
Environmental and socio-economic Impact assessment, The proposed	Petrotek Namibia (Pty)Ltd

CURRICULUM VITAE

Chris Elungi AILONGA

Petrotek Fuel retail fuel facility at HKIA Airport, Windhoek.	
Environmental and socio-economic Impact assessment, The proposed NDC Kalkfeld Fuel retail facility, Kalkfeld.	Namibia Development Corporation (NDC)
Environmental and socio-economic Impact assessment, The proposed Oshikuku Fuel retail facility, Oshikuku.	Kobra Investments cc
Environmental and socio-economic Impact assessment, The proposed Oluzizi Fuel retail facility, Outapi.	Puma Energy Namibia Ltd
Environmental and socio-economic Impact assessment, The proposed Henties Bay Fuel retail facility, Henties Bay.	Puma Energy Namibia Ltd
Environmental and socio-economic Impact assessment, The proposed Gobabis Fuel retail facility, Gobabis.	Soft Cloud Investments (Pty) Ltd
Environmental and socio-economic Impact assessment, The proposed Ongwediva Fuel retail facility, Ongwediva.	A & S Entertainment
Environmental and socio-economic Impact assessment, The proposed Lafrenz Fuel retail fuel facility in the northern Industrial area, Windhoek.	Shell Namibia (Pty) Ltd
Environmental and socio-economic Impact assessment, The proposed 4-star Hotel, in Oshikango	Sun Square Hotel (Pty) Ltd
Environmental and socio-economic Impact assessment, The proposed Omafo Fuel retail fuel facility in Ohangwena region	Jack Kapolo
Environmental and socio-economic Impact assessment, Environmental Compliance Audit , The proposed Wenela Fuel retail fuel facility in Katima Mulilo.	Wenela Service Station
Environmental and socio-economic Impact assessment, Environmental Compliance Audit , The proposed B-One Fuel retail fuel facility in Rehoboth.	Erno Van Wyk
Environmental and socio-economic Impact assessment, The proposed Ongha Fuel retail fuel facility in Ohangwena Region	Marylin Properties (Pty) Ltd
Environmental and socio-economic Impact assessment, The proposed Swakopmund Strand Hotel , Swakopmund	Olthaver and List (Pty) LTD
Environmental and socio-economic Impact assessment, The proposed Kaap Agri Fuel retail fuel facility , Rehoboth	Shell Namibia (Pty) Ltd
Environmental and socio-economic Impact assessment, The proposed upgrade of Omakange-Ruacana road (85km) to bitumen standards.	Min of Works and Transport
Environmental and socio- Impact assessment, The proposed upgrade of Omafo-Outapi (100km) road to bitumen standards.	Min of Works and Transport
Environmental Impact assessment, The proposed waste water treatment Plant, Oshakati.	Oshakati/Ongwediva Town Council
Environmental and socio-economic Impact assessment, The proposed quarantine camps in Katima and Kopano, Caprivi Region.	Millenium Challenge Account

CURRICULUM VITAE

Chris Elungi AILONGA

Environmental Scoping Assessment, Beneficial Utilisation of biosolids at Gammams Waste Water Treatment Works, Windhoek	City of Windhoek
Environmental and socio-economic Impact assessment, The proposed fuel wholesale facility in Windhoek, Shared Petroleum	Shared Petroleum (PTY) LTD
Environmental Impact assessment, The proposed upgrade the fuel retail facility in Luderitz, Coastways Service Station	Engen Namibia (PTY) LTD
Environmental Impact assessment, The proposed expansion of the chemical handling facility at the port of Walvis Bay, Protea Chemicals Namibia - Omnia Group	Protea Chemicals Namibia (PTY) LTD Omnia Group
Environmental Impact assessment, The proposed bulk fuel storage facility in Walvis Bay, Merlus Properties	Merlus Properties (PTY) LTD
Environmental Impact assessment, The proposed bulk fuel storage facility in Rehoboth, St Mary's Hospital	St Mary's hospital
Environmental Impact assessment, The proposed upgrade the fuel retail facility in Windhoek, Eureka Service Station	Engen Namibia (PTY) LTD
Environmental Impact assessment, The proposed bulk fuel storage facility in Walvis Bay.	NAMCOR (PTY) (LTD)
Environmental Impact assessment, The proposed fuel retail facility in Ongwediva.	Querida's Enterprises/ Shell Namibia
Environmental Impact assessment, The proposed bulk fuel storage and consumer facilities in Karibib, Anglo Gold Mine.	Anglo Gold Ashanti - Navachab mine
Environmental Impact assessment, The proposed bulk fuel storage and consumer facilities at Langer Heinrich Mine, Erongo region	Langer Heinrich Uranium / Shell Namibia
Environmental Impact assessment, The proposed bulk fuel storage and consumer facilities at Hosea Kutako International Airport	Dollar Thrifty Car Rentals
Environmental Impact assessment, Bwabwata Exploration/Drilling of diamond exploration in Caprivi Region.	De Beers Marine Namibia/ Namdeb (PTY) LTD
Environmental Impact assessment, The upgrade of the BP Klein Windhoek Service Station.	BP Namibia (PTY) LTD / Klein Windhoek SS

CURRICULUM VITAE

Chris Elungi AILONGA

Other Specialist/Scientific Work

Activity	Client
EMP, Health and Safety plan Compliance auditing and Supervision for CSG Energy Namibia (Pty) Ltd Gas Exploration in the Huab, Kunene Region.	CSG Energy Namibia (Pty) Ltd
EMP, Health and Safety plan Compliance auditing and Supervision for Windhoek Shell Depot, Khomas Region.	Vivo Energy Namibia Ltd
Safety, Health and Environmental awareness training and environmental monitoring of the construction of MR122 (Okahao-Omakange Road).	Roads Authority
Daberas mine hydrogeological study	Namdeb (PTY) LTD
Daberas mine slimes disposal dam site selection	Namdeb (PTY) LTD
Surface and groundwater pollution risk assessment, as a specialist study for Environmental Impact Assessment, Oujere Lifestyle project, Von Bach Dam	Tutungeni Africa Investments (PTY) LTD
Environmental Fatal Flaw Screening, Site selection – Offshore mooring facilities, Walvis Bay	Namcor (PTY) LTD / Namport (PTY) LTD
Chemical Analysis of metallurgical and environmental samples at Trekkopje Mine.	Trekoppje Mine
Pocket Beaches Site 2 Environmental Closure Audit.	Namdeb (PTY) LTD
Daberas Mine Water Quality Assessment.	Namdeb (PTY) LTD
Pollution Investigation, Impact assessment studies on the impact of the Daberas mine tailings dam seepage on the water quality of the Orange River and Riparian Vegetation.	Namdeb (PTY) LTD
Biodiversity Impact Assessment-Power line wayleave on Inhaca island in Mozambique.	SANTED

LANGUAGE PROFICIENCY

	<i>SPOKEN</i>	<i>READ</i>	<i>WRITTEN</i>
<i>English</i>	Excellent	Excellent	Excellent
<i>Afrikaans</i>	Good	Fair	Fair
<i>Oshiwambo</i>		Mother Tongue	