



REPUBLIC OF NAMIBIA

MINISTRY OF ENVIRONMENT, FORESTRY AND TOURISM

DIRECTORATE OF ENVIRONMENTAL AFFAIRS

ENVIRONMENTAL AUDIT - (SELF AUDIT QUESTIONNAIRE)

Please Take Note:

1. All questions are mandatory and thus must be fully completed
2. knowingly providing false or misleading information is an offence as in terms of Section 43 (1) of the Environmental Management Act, Act No. 7 of 2007.

Activity: MAVINGA STONE QUARRY & CRUSHER,
OMATEMBA, RUACANA, OMUSATI REGION

1. OVERVIEW AND GENERAL INFORMATION	
a) Name of the unit and complete address	MAVINGA STONE QUARRY & CRUSHER, OMATEMBA, RUACANA
b) What are the main activities carried out on site?	STONE QUARRY & CRUSHER
c) Number of people employed on site (temporary + permanent)	25
d) Is a copy of the site layout plan available?	YES ATTACHED
e) Are there any other projects in the area having similar activities?	YES
f) Environmental Clearance Certificate (ECC) Number and date issued (if available)	ATTACHED

Initials

2. SITE HISTORY AND DETAILS

a) When was the facility established?	2011
b) Who owns the facility/industry?	MAVINGA TRADING ENTERPRISES
c) Who owns the land and what is the type of the land?	11
d) Is the land ownership/lease document available?	LEASE - COMMUNAL
e) What is the total land area?	4 Ha
f) What was the previous land use of that area (commercial, residential, industrial or agricultural)?	Communal
g) Does the facility have any citations or complaints pending against it?	NONE
h) Has there ever been any major accidents on-site?	NO

3. PROCESS REVIEW	A	N/A	Comments
a) Give a detailed description of the production process.			STONE CRUSHING, SORTING & LOADING
b) Total production capacity of the plant/ project in terms of tonne per annum			40 TONS/DAY
c) What are the inputs required in the production process (preferably in the form of a list containing name, amount/quantity required and their price?)			200L OF FUEL/DAY
d) What are the outputs produced (including pollutants) and their quantities?			GRADED STONES
e) Provide a list of all the machinery and utilities used on-site along with their capacities number, energy			MOBILE STONE CRUSHER (50T/DAY)
f) consumption and time in use.			7hr shift
g) How often is maintenance work carried out on-site?			WEEKLY/DAILY
h) Does any recycling/reuse of material take place on-site?		✓	

4. LICENSE AND PERMITS	A	N/A	Comments
a) Does the facility have a valid factory license? If not, has the facility applied for it? Is a copy of the application form available?		✓	
b) Does the facility have a valid Consent to Operate (CTO) certificate? If not, has the facility applied for it? Is a copy of the application form available?		✓	
c) Does the facility generate hazardous waste? If it does, does the facility have authorization for storage, handling and transportation of hazardous waste as per the Hazardous Waste (Management and Handling) Rules? If not, has the facility applied for it? Is a copy of the application available?		✓	NONE

Initials

5. AIR EMISSIONS	A	N/A	Comments
a) What are the sources of stack and fugitive emissions in the facility?		✓	NONE
b) Has stack and ambient monitoring carried out?		✓	
c) Does emissions meet standards specified in the CTO certificates?		✓	
d) Are monitoring records/reports maintained?		✓	
e) What are the air pollution control device that has been installed?		✓	N/A
f) What is the frequency of cleaning and maintaining the air pollution control device?		✓	
g) Are site processes and operations free of significant fugitive air emissions?		✓	

6. Water consumption and wastewater generation

6.1 Freshwater	A	N/A	Comments
a) What is the source of freshwater? Is it metered or not?			Ruacana Town Council
b) How many boreholes are installed in the site?			NONE
c) How many flow meters are installed in the plant? What are their readings?		✓	
d) Schematic of a raw water treatment plant and DM plant e.g Sceptic tanks, filtering systems etc		✓	Mobile toilets on site
e) Latest groundwater quality test reports		✓	
f) Specify average daily water consumption of the entire plant and in township/colony (m3/day):		✓	DRY PROCESS, water is just for drinking
g) Has the plant / activity studied the impact of its water consumption on respective surface water source and/or groundwater table?		✓	
h) Break-up of average freshwater consumed for last two financial years?		✓	
i) Specific water consumption values for last two financial years (in m3/tonne or m3/Mwh, etc.):		✓	
j) Chemicals used in water treatment plant with quantity and price:		✓	
k) What is the capacity of the demineralization (DM) plant? What is then average quantity of water treated in DM plant (m3/day)?		✓	
l) Does the plant/ project have rainwater harvesting (RWH) system? If it does, is it rooftop, paved or unpaved?		✓	
m) Method of harvesting rainwater—Storage in artificial tanks/recharge into the pit/ trench/well		✓	
n) Total rainwater harvesting potential of the plant		✓	
o) Rainwater harvesting potential of the site developed by the plant:		✓	
p) Total rainwater harvesting done by the plant		✓	
q) Frequency of monitoring of the groundwater quality and quantity (pre- and post-monsoon) and frequency of cleaning the rainwater harvesting catchment/storage system		✓	

Initials

r) How is the harvested rainwater utilized by the plant/ project?		✓	
s) Key measures taken by the plant/project for water conservation in the past three years and water saving achieved in terms of m3		✓	

6.2 Wastewater	A	N/A	Comments
a) Schematic diagram of an Effluent Treatment Plant (ETP) and Sewage Treatment Plant (STP) along with their capacities (attach)		✓	Mobile Toilets used on site
b) Latest laboratory test reports of ETP and STP inlet/outlet streams		✓	
c) Does the plant/ project have separate ETP for its different products?		✓	
d) Total effluent generated by plant/ project (including all products) in last two financial years		✓	
e) Total sewerage generated by plant/ project and colony in last two financial years		✓	
f) Provide the details of wastewater generation and recycling in the entire facility		✓	
g) Does the plant/ project monitor the impact of wastewater on the receiving waterbody/ land?		✓	
h) What is the total number of outlets for effluent discharge from the plant/ project?		✓	
i) Name of WTP unit/s (filtration unit/softening unit/reverse osmosis plant etc.) and its capacity and average quantity of water treated in filtration plant (m3/day)		✓	

7. NOISE POLLUTION	A	N/A	Comments
a) Does the facility have a valid factory license? If not, has the facility applied for it? Is a copy of the application form available?		✓	

8. FUEL CONSUMPTION	A	N/A	Comments
a) List the different type of fuel used in different areas of the plant/ project			Diesel
b) Quantification of fuel used in each process and its calorific value			200L/day
c) How is the industry storing the different types of fuel?			Diesel Bowser
d) If they are using:			
Gas—Is the supply regular? If not, mention the number of hours.		✓	
Biomass—Is it available for the entire year?		✓	
Coal—Are they using low ash coke or high coke and the supply is regular or not?		✓	

Initials

9. CHEMICAL HANDLING AND STORAGE	A	N/A	Comments
a) What are the various types of chemicals stored on-site?		✓	
b) Is a list of chemicals available?		✓	
c) How are chemicals transported?		✓	
d) What kind of containers are there for storing the chemicals?		✓	
e) Are there any above or underground chemical storage tanks on-site?		✓	
f) Are any of the chemicals toxic or harmful? How many of them are hazardous?		✓	
g) Are all the chemicals labelled?		✓	
h) Are the chemical containers' lid closed after use?		✓	
i) Are records of chemicals and dyes usage maintained in the logbook?		✓	

10. SOLID AND HAZARDOUS WASTE MANAGEMENT	A	N/A	Comments
a) What kinds of solid waste are generated on-site?			General litter
b) What is the quantity of solid waste generated?			5kg/day
c) How is the solid waste disposed of?			RUNCANA WASTE DISPOSAL SITE
d) Is any of the waste reused or recycled?		✓	
e) What are the sources of hazardous waste generation on-site?		✓	
f) What is the quantity of hazardous waste generated?		✓	
g) How is the hazardous waste disposed of?		✓	
h) Are hazardous waste disposal records maintained?		✓	
i) Are any of the hazardous wastes treated on-site?		✓	
j) Where are the hazardous wastes stored before disposal?		✓	

11. OCCUPATIONAL HEALTH AND SAFETY	A	N/A	Comments
a) Does the facility have a site emergency plan?			YES
b) If yes, then has this plan been documented?			YES
c) What are the recognized hazards in the facility?			Slips & trips, Hand injuries, falling objects

Initials

d)	Are fire extinguishers available in the facility?			YES
e)	What type of fire extinguisher is available?			DRY CHEMICAL POWDER
f)	Are the fire extinguishers functional?			YES
g)	Are facility personnel trained in its use?			YES
h)	Is personal protective equipment (PPE) available for use?			YES
i)	Do the workers use PPE?			YES
j)	Are health check-ups for workers conducted?			YES
k)	Do the workers know whom to contact in case of an emergency?			YES
l)	Has any accident ever occurred on-site?			NO

Declarations

I, MAVINGA TRADING Enterprises (full name of PROPONENT) understand and agree that the information that I have provided in this questionnaire will be used by the Environmental Commissioner. I accept that the Environmental Commissioner will hold me accountable for any inaccurate or misleading information knowingly provided in this questionnaire, and acknowledge that the provision of such information will impede the lawful carrying out of the responsibilities and functions of the Environmental Commissioner.

I declare that the information that I have provided in this questionnaire is to the best of my knowledge, true and

Reliable.

Signature: 

Date: 29/02/2024

Initials

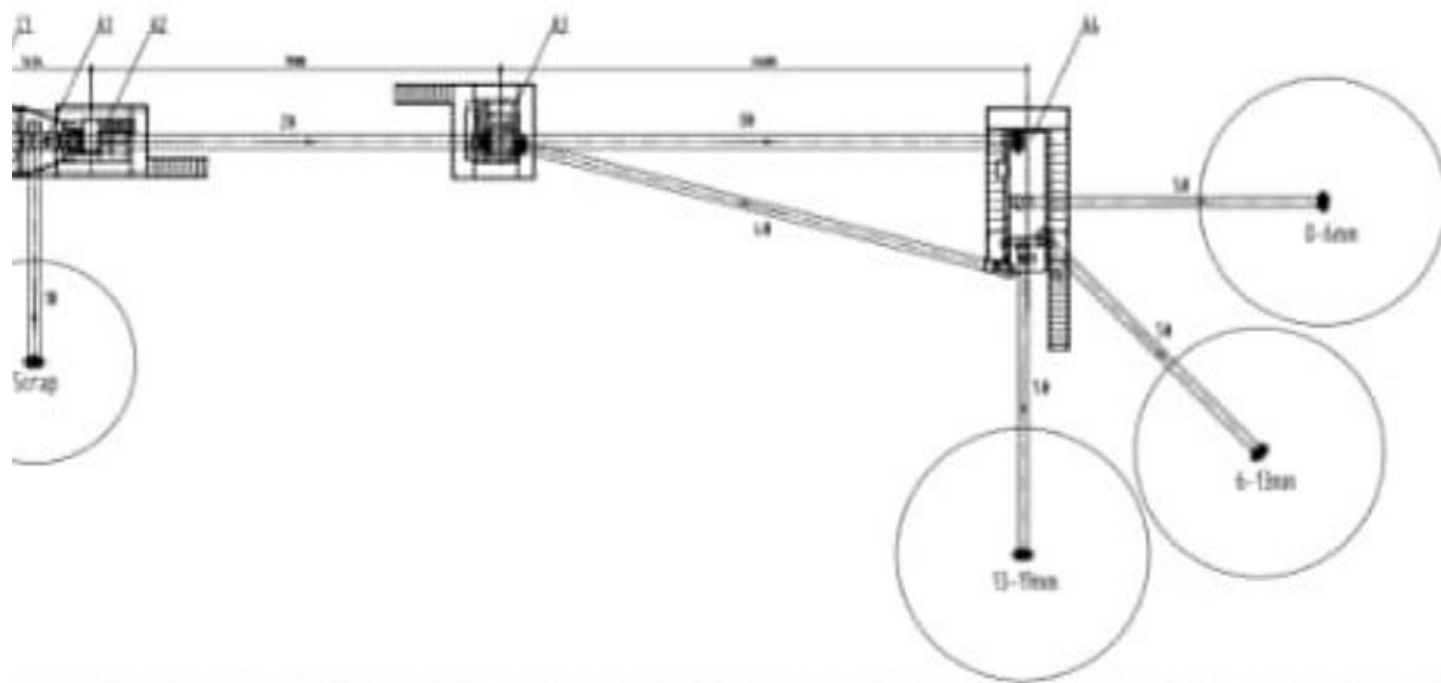
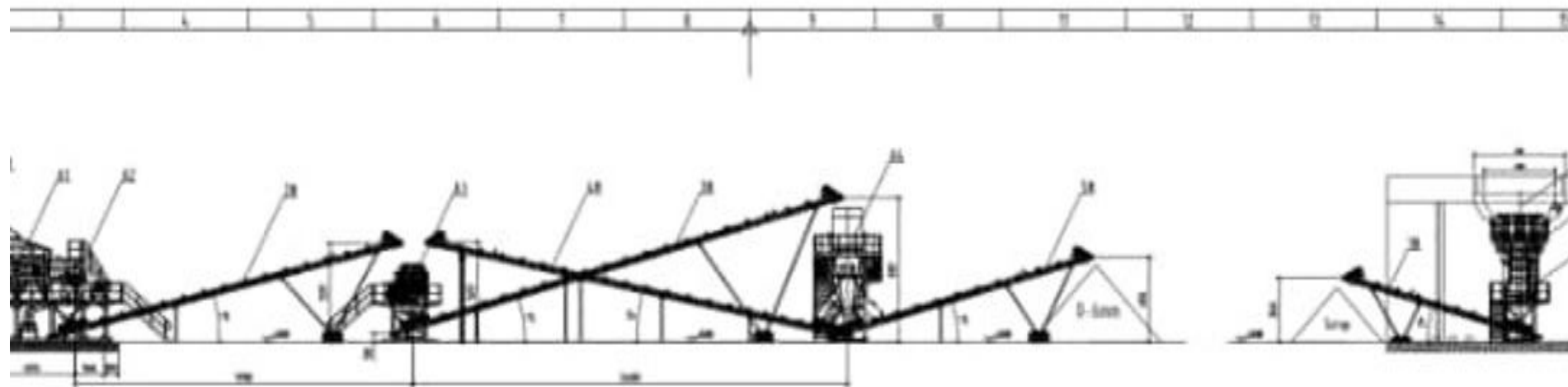

Technical Description:

- 1 This flow chart is based on the customer's required output (can change with the features of raw material, its condition). The traffic is only for reference.
- 2 Making corresponding adjustment in actual contract please refer to the legend for actual model length in 1.
- 3 Shaft gear shaft and the distance should be in accord specification.
- 4 The real content of raw material should be under 80% great difference to the capacity, machine and process.
- 5 This figure is frequently for reference and discuss drawings.

75000



P. O. Box 16144, Oshihole - Onesi
Namibia

Uukolonkadhi Traditional Authority

Enquiries: Mr. Malakia Shoombe
Cell: 0813493070/0814018407
E-mail: uukolonkadhi@ gmail.com

30 January 2024

Dear Sir/Maddam

RE: Mavinga Crusher –Ruacana (Omatemba village)

This letter serve as reference from our declaration dated 14th January 2010 confirming that the Uukolonkadhi Traditional Authority had agreed to allocate Mr.Fabianus Paulus ID: 601018002207 a resident of Otjorute village and owner of Mavinga Trading Enterprises CC a Portion of land at Ruacana Constituency in 2010, where he has since established a Crusher, permanently.

The Uukolonkadhi Traditional Authority has no objections with Mr.Fabianus crusher whatsoever and confirms that his crusher operation may continue going forward.

I trust that you find all in good order and should you have any concerns in this regard, please do not hesitate to contact the writer hereof.

Yours Sincerely

P. Malakia Shoombe

Mr. Malakia Shoombe
Acting Chief of Uukolonkadhi Traditional Authority
Cell: 0814018407

